

ISSN: 1304-6799

DETAY®

A WEEKLY ECONOMIC MAGAZINE

- Tenders, Projects and Investments In 2017
- A General Panorama In Economy
- Prospects In 2018



March 2018
SPECIAL
SUPPLEMENT

www.detayhaber.com.tr

32nd
year



Karla Oynamayı Seviyoruz.

MAN Kamyon ve Otobüs Tic. A.Ş.
Esenboğa Havalimanı Yolu 22. Km 06750 Akyurt/ANKARA
Tel : 0 312 556 10 00 Faks : 0 312 556 10 41
www.man.com.tr

f mantruckandbusturkey
mantruckbusturk





Belediyecilikte
çözüm ortağınız.

Mercedes-Benz
Trucks you can trust





Kanıtlanmış Kalite

1866'dan Bugüne...

150 yıldır İtfaiye Araçlarında ve Yangın Söndürme Teknolojilerinde Standartları Yükselten Rosenbauer'in İleri Teknolojisini ve Kalitesini Türkiye'ye Sunmaktan Gururluyuz.



UMTAŞ Uluslararası Makina Tic A.Ş.

Büyükdere Cad. No:85 Stad Han Kat:7

34387 Mecidiyeköy/İSTANBUL

Tel: (0212) 275 87 81 / Fax: (0212) 275 87 84

Eposta: umtas@umtas.com.tr



www.umtas.com.tr

36 YILDIR

Türkiye'nin Geleceği İçin Çalışıyoruz.

Güveninizi hiç yitirmeden, sonsuz bir enerjiyle ve daha iyisi için hep merakla...



OKT-TRAILER.COM
+90 444 1 655

-  okt.trailer
-  okt.trailer
-  company/okt-trailer
-  okt.trailer



OKT TRAILER

Experience the Progress.



Tower Crane Solutions for Wind Turbines

- Liebherr has become the first manufacturer of tower cranes to develop a complete package.
- Tower cranes can operate precisely even in high wind speeds.
- **Easy to transport:** The logistics cost for transporting a tower crane is much lower than for comparable crane systems.
- **Require very little space for erection:** The area requirement for erecting the crane is around 50 % of other crane systems.
- **High working speeds:** Loads can be lifted at speeds of up to 37 m/min.
- **Everything in view:** A perfect view of the load makes it easier for the crane driver to position units precisely.

LiebherrMakineTicaretServisLtd. Sti.
Y.DudulluMah. KibleSok. No:36 Şerifali
Ümraniye/İstanbul -Türkiye
Tel.: +90 (216) 453 10 00
Fax: +90 (216) 466 99 05
E-Mail: info.lbc@liebherr.com
Internet: <http://liebherr.com>

LIEBHERR



Alırken, kullanırken, yenilerken hep yanında. Kazandıran Sprinter.

Her işe tam zamanında yetişenlerin tercihi Sprinter, şimdi hem alırken hem kullanırken hem de yenilerken kazandırıyor. Satış, satış sonrası, ikinci el ve finansman hizmetlerimizle tanışmak için sizleri showroom'larımıza bekliyoruz.

Mercedes-Benz



DETAY

A WEEKLY ECONOMIC MAGAZINE

Established in : 1987

Founders : R. Tayfun DİLÇİN
Behçet AKDOĞAN

DETAY

PUBLISHING ADVERTISING
AND MARKETING LTD. ŞTİ.

Publishing &
Managing Director

R. TAYFUN DİLÇİN

Managing Editor

BEHÇET AKDOĞAN

Publishing Director

İBRAHİM KINACI

Turkish Version Editor

ERDEM AKDOĞAN

Translation Director

ERGÜN ŞEN

EDITORIAL CENTRE

Fevzi Çakmak Sokak, Doğu Apt.
33/13-16, Kat.4, 06440, Kızılay
ANKARA

Tel : (0.312) 230 73 62 – 232 08 80

231 24 99 – 232 08 81

Fax : (0.312) 231 38 25

e-mail: detayhaber@hotmail.com

detayhaber@yahoo.com

info@detayhaber.com.tr

ISSN 1304 - 6799

DETAY Publications

Type of Publication: Local Periodical

DETAY Haftalık Ekonomik Haber Dergisi

DETAY Weekly Economic Magazine

www.detayhaber.com.tr

Printed by: **Ayrıntı Basım Yay. Ltd. Şti.**

Address: 28.Cd. 770 Sk. No:105 İvedik

Organize Sanayi Sitesi-Yenimahalle / ANKARA

Tel: 0312 394 55 90

Information in the *Tenders Review* is prepared only for the subscribers of **DETAY** Economic Magazine and can not be published elsewhere without reference.
Its distribution is for FREE.

**THIS MAGAZINE HAS PLEDGED TO
CONFORM TO THE PRESS
PROFESSIONALS' CODE OF ETHICS.**

March 2018

ISSN: 1304-6799

Dear Readers,

DETAY Economic Magazine is in its 32nd year.

We are glad to share our pleasure for having our magazine reach such a level, thanks to this togetherness since 1987.

Having gained great experience in the media sector for thirty-one years in Turkish and English on weekly basis, **DETAY Economic Magazine** is celebrating its 32nd anniversary of publication on 6 April 2018.

Our website www.detayhaber.com.tr, which was upgraded in summer 2017, has also been accessible since 2004 and we thank our followers who have made it one of the most visited websites in its sector with daily 65.000 clicks. We look forward to further years of publication to provide the readers with 'accurate and elaborate' reports in the magazine and the website.

Now we are distributing our new supplement, the 32nd **Tenders Review** in Turkish & English, which supplies you with major projects & investments realized in 2017 and various economic forecasts of 2018 in Turkey.

Among the major projects that had been in the coverage all year round in different issues and on the website www.detayhaber.com.tr last year were BOTAŞ's naturalgas pipelines, YEKDEM renewable energy projects, İstanbul M. Municipality's subway projects, DSI's drinkingwater projects, İstanbul M. Municipality's subway projects, Health Ministry's hospital constructions in various locations, TEİAŞ- led energy lines, TOKİ's housing projects.

Our supplements, highlighting some economic reviews as well as information on various other sectors, including privatizations, defense industry projects, iron-steel & cement sector reviews, are being issued for 'free' to all the public institutions, governorships, municipalities, provincial administrations, foreign embassies, offices of trade attaché, foreign firms in Turkey, land-sea-air transport companies, firms operating in the iron-steel sector as well as in the automotive, logistics and inspection sectors.

Dear Readers,

We would welcome your criticism about the content of the Supplement, which has appeared after a three-month preparation, and for any errors that might have occurred despite our careful editing. Any recommendations from our readers are taken into consideration for the next issues.

We wish all mankind to have a prosperous year, with urgent relief and peace for the Middle East in 2018.

Read DETAY & Widen Your Horizon.

Articles in this magazine are their authors' personal views for which **DETAY ECONOMIC MAGAZINE** cannot be made responsible.

INDEX

■ A Review Of Business & Economic Developments In 2017	10
■ Obligation To Use Domestic Goods In Construction Works	18
■ CENTRAL BANK's 2018 Monetary & Exchange Rate Policy	20
■ 2018 Investment Program's Project Value 804.6 Billion TL	22
■ 2018 Program Implementation In Official Gazette	23
■ Exports Reached \$157.1 Bln Value In 2017	24
■ Kanal İstanbul Project's Route Unveiled	28
■ TÜİK Announces December Inflation Figures	30
■ Mercedes-Benz Türk Marks Global Achievements In Its 50th Anniversary	33
■ FORD TRUCKS Has Doubled Its Market Share In The Last Ten Years	36
■ Foreign Trade Deficit \$76.7 Billion In 2017	38
■ OTOKAR Maintains Its Leadership In 2017	39
■ Having Had Further Strength In 2017, MAN Welcomes 2018 With Innovations, Advantages And Awards	42
■ Turkish Contractors' Undertakings Gain Majority In Housing Sector Worldwide 44	
■ 2018 Minimum Wage Raised To Net 1603 TL	44
■ Turkey's 2017 Cement And Clinker Figures	46
■ Emlak Konut GYO's Sales Reach A Turnover Of 7.7 bln TL In Housing	48
■ Turkish Automotive Industry Figures For January-December 2017 Issued	49
■ Banking Sector's Forecasts In 2018	53
■ Exports In Turkish Lira Rise Five Fold In 7 Years	54
■ Public Allocation 8.5 Bln TL To Two Sectors	55
■ Government's Special Incentive Mechanism To Be Put Into Force	55
■ 2018 Will Be Year Of Tax Reforms	56
■ Developments In Agriculture In 2017	57
■ Sees To Make 20 Bln TL Worth Of Investments In 2018	58
■ 2018 Budget Ratified	59
■ UND President: Customs Procedures Biggest Problem For Land Transportation Sector	60
■ Three -Level İstanbul Tunnel Project Construction Tender To Be Held In 2018 61	
■ The Number Of Newly Launched Companies Rises By 14% In 2017	61
■ Number Of Cars In Fleet Reaches 346.000 Units	62
■ Joint Venture Set Up To Produce First Domestically- Produced Car	63
■ Investments In Wind Power (RES) Exceed \$1 Bln	64
■ 2018 Investment Program's Project Value 804.6 Bln TL	67
■ İzmir ESHOT's Budget Ratified	68
■ Gaziantep Metropolitan Municipality's 2018 Budget Disclosed	68
■ Fiscal Year Budgets Of İstanbul's 39 Districts For 2018 Ratified	69
■ Ankara Metropolitan Municipality Plans To Procure Vehicles In 2018	69
■ Ankara Metropolitan Municipality EGO And ASKİ 2018 Budgets Ratified	70
■ Sakarya Metropolitan Municipality Vehicle Procurements In 2018	71
■ Bursa M. Municipality's 2018 Vehicle Procurement List Disclosed	72
■ İstanbul-İSKİ General Directorate's 2018 Investment Program	73
■ List Of Vehicles To Be Procured By State Managements In 2018 (T- Table)	82
■ Projects On The Agenda	91
■ Consultancy & Survey Projects	105
■ Industrial Raw & Auxiliary Material Tenders	114
■ Transport Tender Results	118
■ Machinery & Equipment Tender Results	122
■ Construction Tenders	131
■ 474 Fair Organizations Are Scheduled To Take Place In 2018	142

ADVERTISEMENTS

■ ZİRAAT BANKASI	Back Cover
■ MERCEDES CONECTO	Back in Cover
■ MAN KAMYON	Front in Cover
■ MERCEDES BENZ KAMYON	1
■ UMTAŞ MAKİNA	2
■ OKT TRAILER	3
■ LIEBHERR MAKİNE	4
■ MERCEDES BENZ (SPRINTER)	5
■ İMİ MAKİNE	8
■ TEKBOR	9
■ ÇEKSAN	13
■ FORD TRUCKS	17
■ TEKNİK TANKER	19
■ NESA TAŞIT ÜST YAPIM	21
■ FIAT	25
■ KARBA OTOMOTİV	27
■ OTOKAR A.Ş.	29
■ ALTINOK MÜŞ. MÜH. A.Ş.	31
■ ZF ŞANZİMAN	35
■ EMS MOBİL SİSTEMLER A.Ş.	37
■ TÜRK KIZILAYI DERNEĞİ	41
■ LÖSEV VAKFI	45

İMİİ MAKİNE

www.imimakine.com.tr

📍 Atatürk Bulvarı No: 105/809 📞 (0312) 425 10 06
Kızılay / ANKARA 📠 (0312) 418 67 55

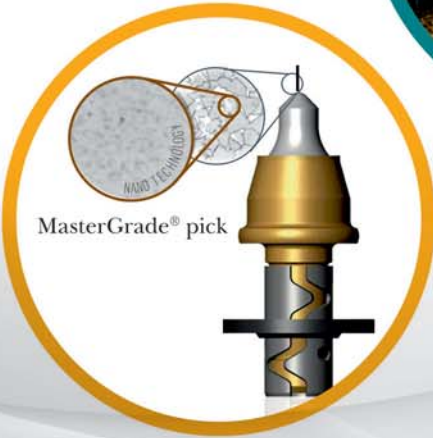

TEKBOR

"Hayat Taşır"



Telefon: +90(412) 456 6052 • **Mail:** tekbor@tekbor.com.tr • **Fax:** +90(412) 456 6085

Adres: Bismil Diyarbakır Yolu 8.Km Bismil/DİYARBAKIR

www.tekbor.com.tr

A REVIEW OF BUSINESS & ECONOMIC DEVELOPMENTS IN 2017



After the Turkish economy had had to experience the year 2016 with hardships due to some challenging developments and other terror acts to various regional and global turmoils, it marked the year 2017 with a growth performance. The double digit growth rate has differentiated the Turkish economy from the EU, G20 and OECD countries in the 3rd quarter of 2017.

According to a compilation, Turkey's strong growth performance exhibited in 2017 exceeded the forecasts of international institutions and organizations such as the International Monetary Fund (IMF), World Bank, Moody's and Fitch. These organizations had to go to revision in their projections for Turkey's economy.

Turkey's economy grew by 5.3 % in the first quarter, 5.4 % in the second quarter, 11.1 % in the 3rd, and 11.6 % in the third quarter of 2017, and it has caught the highest growth performance after 23 quarters with an average % 2.5 times more than the EU countries.

Even if Turkey's economy records a zero growth performance in the fourth quarter, the 5.5 % growth target has been approached as predicted in the Medium

Term Program (OVP) for 2017, by means of the 3rd quarter figures.

With Premier Binali Yıldırım-led 66th Government established, there were changes in the management of the economy. While some ministries had new names, some other ministers left. Mehmet Şimşek became the Deputy Prime Minister responsible for the coordination of the economy and public banks.

Arrangements that enable the economy to breathe

In order to dissipate the negative atmosphere created by the turmoil in the international conjuncture and the surrounding countries and to stimulate the economy, some regulations that relieve both real sector and the citizen's pocket have been put into force.

Access of the SMEs and exporters to financing has been facilitated. For this purpose, the upper limit of the amount of the remainders of the bails provided by the Credit Guarantee Fund (KGF) in Treasury-backed loans has been increased from 20 to 250 billion TL.

While a portfolio guarantee system (PGS), which accelerates the bailing process, has been established, the Treasury has been assigned to go bail for those out of KOBİs (SME) by 85%, for KOBİs by 90% and for the exporter by 100%, depending on the situation of the loan. In order to stimulate the construction sector, VAT (KDV), stamp tax and title deeds were levied. A record amnesty of the registry involving millions of citizens and companies that had borrowed earlier from banks entered into force.



While the Law on the Restructuring of Certain Receivables No 7020, which aims to structure some public receivables, came into force, the applicants who had failed during the previous restructuring period (Law no. 6736) have been given a second chance as they had lost their rights because they could not make their payments on due time. The Private Consumption Tax ("ÖTV"), which is received from white appliances and some small household appliances, has been reduced to 8%, which revived these sectors and opened the way for the citizens to buy these goods at cheaper prices.

Defense industry Show

The Turkish defense industry has experienced the excitement of the International Defense Industry Fair (IDEF) this year. Domestic companies have stamped their potential with their indigenous and innovative products. The inventory of the Turkish Armed Forces and security forces has been strengthened through the introduction of domestic products.



Several projects have been launched to produce domestic engines that are critical to reducing foreign dependence on defense industry products. A final test shot of 280 kilometers from Sinop to the offshore of the Black Sea was successfully carried out before the delivery of the KAAN Missile, developed by Roketsan before delivery to the Turkish Armed Forces.

Turkish car sets on the way

The Medium Term Program (OVP), which has outlined the road map for the economy, has envisaged the Gross Domestic Product (GDP) to exceed 4 trillion dollars, inflation figures to drop to 5% gradually, and unemployment to go down to single digits by 2020.

The Turkish local automobile deal was signed up. President Erdoğan announced the companies that will produce the automobile at the Promotion Meeting for Turkey's Automobile Joint Venture. They are Turkcell, BMC, Kıraca Holding, Zorlu Holding and Anadolu Group. The foundation was laid for "1915 Canakkale Bridge", the longest intercity spanned bridge in the world and Malkara-Canakkale Motorway.

2.5 tons of gold came out of the pillow

In order to earn the gold out of the pillow, gold bonds and gold-based rental certificates were issued. In October, during the initial demand period of 4 weeks, about 2.5 tons of gold worth 370 million TL were taken out of pillows. In order to prevent the increases in red meat prices in the domestic market, customs taxes applied on slaughtered livestock and carcass beef were reduced.

Increase in MTV debated

The sharp rise of the Motor Vehicle Taxes (MTV) was also among the agenda items of 2017.

The MTV, which had been announced by Finance Minister Naci Ağbal to be up by 40 % was revised to 25% in the "bag law" upon public reaction and the notice of President Recep Tayyip Erdoğan.

The major economic events witnessed in Turkey in 2017 have been compiled as follows:

5 January

- Transportation Minister Ahmet Arslan said that Baku-Tbilisi-Kars railway will go into service in mid2017

7 January

-Tim said that Turkey's exports declined to \$142.6 billion in 2016 with a 0.8 % decrease compared to 2015

14 January

-The 2017 Investment Program has been put into effect following its publication in the 14 January Official Gazette with reference to the Council of Ministers annex decision on implementation, coordination and monitoring of the Program

30 January

- OSD said the automotive production in Turkey surged 31 % year-on-year in the first month of 2017.

14 January

-The 2017 Investment Program has been put into

3 February

-The World Bank and Turkey's gas grid BOTAŞ signed a \$400 million financing deal

8 February

- EPDK data showed Turkey's oil imports rose 24.26 % in January.

24 February

- The Free Zone Regulation was officially gazetted on 24 February 2017.

3 March

-TÜİK said that in February, TÜFE (CPI) rises by 0.81 % and Y-ÜFE (D-PPI) by 1.26 %...

8 March

-Tim announced that Turkey's exports rose to \$11.3 billion in February with a 5.1 % increase compared to the same month of 2016.

13 March

- Turkish Steel Sector exports recorded a rise, the highest in the last 4 years, amounting to 3,2 million tons in the first two months of 2017.

24 March

-Undersecretariat of Treasury and Credit Guarantee Fund signed a protocol for a new credit guarantee system that aims to benefit SMEs

3April

-In March 2017, TÜFE (CPI) rises by 1.02 % and Y-ÜFE (D-PPI) rises by 1.04%.. On annual basis, inflation in TÜFE becomes 11.29% and in Y-ÜFE 16.09

7 April

-TİM said that Turkey's automotive sector hit a record high exports in the first quarter of 2017

12 April

-Central Bank signed bilateral agreements with the Central Bank of Bosnia and Herzegovina and the National Bank of Georgia.

20 April

-Finance Minister Naci Ağbal stated that government

ran a budget deficit of 19.5 billion TL (\$5.32 billion) in March and 14.9 bln TL (\$3.7 bln) in the 1st quarter.

25 April

- Banks Association of Turkey (TBB) said that Turkish banking sector achieved its highest growth rate in the last six years in the first quarter of 2017

1 May

-TIM said exports increased by 4 % year-on-year to reach almost \$11.9 billion in April on the backs of the steel, automotive, mining and jewelry sectors.

3 May

- In April 2017, TÜFE (CPI) rises by 1.31% and Y-ÜFE (D-PPI) by 0.76 %..On annual basis, inflation in TÜFE becomes 11.87 % and in Y-ÜFE 16.37 %...

8 May

-BDDK said the combined net profits of Turkey's banking sector rose 65.02 % to 13.5 billion TL (\$3.8 billion) year-on-year in the first three months of 2017.

15 May

- Central Bank said foreign direct investment (FDI) in Turkey increased by 43 % in the first 3 months of 2017 compared to the same period of 2016, reaching around \$1.7 bln.

-Turkish Aerospace Industries (TAI) announced the signing of a \$292 million production deal with aircraft parts maker Spirit AeroSystems Holdings Inc.

1 June

- Finance Minister Ağbal stated Turkey ran a budget surplus of 6.4 billion TL (\$1.8 billion) in May, mainly thanks to a significant boost in tax revenues.

NEDEN ÇEKSAN?

Sizi dinler ve beklentileriniz doğrultusunda teknolojimizi üretiriz...



Yüksek Teknoloji



Güvenilir ve Çevre Dostu



Teknik Danışmanlık



Yaygın Servis Ağı



Sürekli İyileştirme

A.O.S.B. 10014 Sk. No: 9 PK: 35620 Çiğli / İZMİR
Tel : +90 232 328 11 66 (Pbx)
Fax : +90 232 328 12 34

info@ceksanmakina.com
www.ceksanmakina.com



3 June

-In May 2017, TÜFE (CPI) rises by 0.45 % and Y-ÜFE (D-PPI) by 0.52 %..On annual basis, inflation in TÜFE becomes 11.72 % whereas in Y-ÜFE 15.26 %..

10 June

-ISO disclosed the list of Turkey's largest 500 industrial companies, with a total of five automotive firms taking place in the top 10. TÜPRAŞ placed first among the largest 500 firms in Turkey..

20 June

-Turk Eximbank signed three-year syndicated loans worth 186.5 million euros (\$208 billion).

22 June

-Turkey attracted \$765 million in foreign direct investment (FDI) in April 2017, the Economy Ministry said on June 22.

29 June

- Russian presidential aide Vladimir Kozhin said Moscow and Ankara agreed on the delivery of the S-400 air defense system to Turkey

3 July

- TÜFE (CPI) decreased by 0.27 % in June, while the Yİ-ÜFE (D-PPI) increased by 0.07 %. Annual inflation was 10.90 % in consumer prices and 14.87 % in domestic producer prices.

5 July

- US ban on electronics as imposed in the cabin on flights from Turkey, has been removed from Turkish Airlines scheduled flights from Atatürk Airport to New York .

7 July

- Deputy Prime Minister Nurettin Canikli stated that business trustees had been appointed to 965 companies from Turkey's 43 provinces under the scope of the Decree Laws, or the powers of the trustees had been transferred to the Savings Deposit Insurance Fund (TMSF). Canikli said, "TMSF has been the trustee for the assets of 107 real persons, and their total asset size of these companies is about 41 billion liras."

11 July

- The "Risky Insured Pool" model, which will share high-risk vehicles with premiums and damage

insurance companies such as taxis, minibuses and buses, has entered into force.

12 July

- Purchase price of milling red hard wheat for 2017 is determined as 940 TL per ton

17 July

- In June, central government budget deficit was realized as 13.7 billion TL. January-June period budget deficit was 25.2 billion TL.

- The unemployment rate increased by 1.2 %age points to 10.5 % in April..

19 July

- Prime Minister Yıldırım announced the new cabinet. While 15 ministers stayed in place, 5 new ministers were appointed and 6 ministers were exchanged posts and remained in office.

21 July

- Turkish Patent and Trademark Authority realized the transfer of 734 brands, 72 designs and 15 patents belonging to Fetö to TMSF. A total of 687 brands and 29 designs were transferred to the Treasury in connection with the operations of the FETO.

24 July

- The new Cabinet's distribution of tasks: The coordination of the economy was awarded to Deputy Prime Minister Mehmet Şimşek .

26 July

- ASELSAN was placed 57th , ROKETSAN ranked 98th and TUSAŞ 61st in the list of the world's top 100 defense companies.

- Deputy Prime Minister Mehmet Şimşek reported that no investigations, prosecutions or investigations were being conducted on any German company under the framework of financing of terror acts.

31 July

- Turkish exports, recorded an increase of 2.3 % and amounted to 13 billion 166 million dollars, In June compared to the same month of 2016, while imports decreased by 1.5 % to 19 billion 177 million dollars. In June, foreign trade deficit decreased by 9.1 % to 6 billion 11 million dollars.

- In the January-June period, exports increased by 8.2 % to 77 billion 453 million dollars, while imports rose by 8.7 % to 108 billion 324 million dollars.

-Turkey's tourism revenues increased by 8.7 % in the second quarter compared to the same period last year, it was 5 billion 413 million 48 thousand dollars, compared to the same period of 2016.

3 August

- TÜFE increased 0.15 % in monthly basis and 0.72 % in Yİ-ÜFE in July. Annual inflation was 9.79 % in consumer prices and 15.45 % in domestic producer prices.

- Semahat Sevim Arsel became Turkey's tax record holder, for the year 2016, for the tax accrued as 46 million 885 thousand 202.91 TL.

9 August

-Transportation, Maritime Affairs and Communications Minister Ahmet Arslan said that in July Turkey's aircraft movements on landing and take-off basis were placed 1st in European airspace on a daily average by adding 283 new traffic .



15 August

-The unemployment rate in May increased by 0.8 %age points to 10.2 % compared to the same period of 2016.

17 August

- TMO said it will purchase Giresun hazelnut for 10,5 liras and 10 liras for the Levant quality hazelnut.

23 August

- The first direct sea route between Turkey and Qatar line opened.

3 September

-Minister of Transport, and Communications Arslan said that the project contract has been signed to clarify the route of Kanal İstanbul Project and to reveal its sections.

5 September

-TÜFE rose 0.52 % and Yİ-ÜFE 0,85 % in August. Annual inflation was 10.68 % in consumer prices and 16.34 % in domestic producer prices.

11 September

- TÜİK revised the growth figure of Turkey's economy from 5.1 to 5.4 % In the secondquarterof2017

15 September

- Unemployment rate in Turkey was 10.2 %, unchanged compared to the same period in June 2016. the number of unemployed increased 124 thousand people and was recorded as 3 million 251 thousand persons.

27 September

- Growth in the new OVP is estimated to be 5,5 %in 2018, 2019 and 2020. It is predicted that GDP will reach 3 trillion 446 billion, 3 trillion 872 billion and 4 trillion 321 billion liras respectively in the years to come..

- Finance Minister Naci Ağbal announced that they would make a change in the Revenue Taxation Scheme applied to all income, which would apply to wage incomes as from 1 January 2018 and from other earnings as from 2017 earnings.



30 September

- Tax cuts launched in February on white goods and furniture sales ended.

3 October

- TÜFE increased by 0.65 % in September and by 0.24 % in the Yİ-ÜFE. Annual inflation was 11.20 % in consumer prices and 16.28 % in domestic producer prices.

5 October

- The 2018-2020 Budget Call and Medium Term Fiscal Plan was published in the Official Gazette.

6 October

- Transport, Maritime and Communications Minister Ahmet Arslan said that Airbus quoted the most favorable proposal in terms of financial and local contribution in the construction of Türksat 5A and 5B satellites

16 October

- Ağbal said Turkey's 2018 budget expenditures were estimated to be 762.8 billion TL, budget revenues 696.8 billion TL , tax revenues 599.4 billion TL.

19 October

- World Bank raises 2017 growth forecast for Turkey to 3.6 % from 4 %.

29 October

- "Baku-Tbilisi-Kars Railway Line" opening ceremony was held in Baku with the participation of President Recep Tayyip Erdoğan, President of Azerbaijan İlham Aliyev, Prime Minister of Kazakhstan Bakıtcın Sagıntayev, Prime Minister of Uzbekistan Abdulla Aripov and Prime Minister of Georgia Giorgi Kvirikashvili.

30 October

- Turkey's tourism income in the third quarter of this year increased 37.6 % compared to the same period of 2016, reaching 11 bln 391 mln 668 thousand dollars.

- Turkey's exports rose 8.7% in September compared to the same month of 2016 and became 11 billion 848 million dollars, and imports increased by 30.6 % and became 19 billion 982 million dollars.

1 November

- Meat and Dairy Authority started to sell mince meat for 29 TL and cubed meat for 31 TL in 81 provinces in some chain markets (A101 and BİM),

2 November

- President Recep Tayyip Erdoğan announced 5 companies that will produce domestic car at the "Turkish Automobile Joint Venture Group Promotional Meeting". Accordingly, Turkcell, BMC, Kırça Holding, Zorlu Holding and Anadolu Group will produce the domestic car.

3 November

- In October TÜFE up by 2,08, Yİ-ÜFE up by 1,71 %. Annual inflation in consumer prices became 11,90, and in domestic producer prices 17,28 %..

8 November

-The calendar adjusted industrial production index increased by 10.4 % in September on an annual basis, while seasonal and calendar adjusted industrial production rose by 0.6 % in September compared to the previous month.

-Customs and Trade Minister Bülent Tüfenkci stated that the necessary consensus was reached regarding the planned Ovaköy Border Gate as an alternative to the Habur Border Gate.

9 November

- Airbus, which won the contracts for Türksat 5A and 5B satellites, signed a contract with Türksat AŞ. Communications Minister Ahmet Arslan said that decision had been given to launch the satellites through Falcon 9 rockets of SpaceX, Airbus subcontractor.

- Development Minister Lütfi Elvan stated that the total of public and private sector investments in 2018 will exceed 1 trillion liras for the first time and "Investment of private sector will be 922 billion and the share of the public will be 141.2 billion TL." he said.

15 November

- Unemployment decreased 0,7 points in August as compared to the same month of 2016 to 10,6 %.

22 November

- A loan agreement worth a total of 2.25 billion TL was concluded between Turkey and Islamic Development Bank during the COMCEC 33rd Ministers' meeting.

23 November

- Net international direct investment inflow to Turkey decreased by 18.8% in January-September period, and became 7 billion 340 million dollars.

24 November

- While the Corporate Tax is set at 22 % for 2018, 2019 and 2020, the Council of Ministers has been authorized to reduce it by up to 20 %.

4 December

- Defense Minister Nurettin Canikli said Turkey's national combat jet TF-X will become operational by 2023.

5 December

30 percent of the offshore construction of the Turkish Stream Pipeline completed.

8 December

- Industrial production rose by 0.7 % in October compared to the previous month.

Şehrin her zaman bir kurtarıcıya ihtiyacı vardır

Ford Trucks 1833 çift kabin itfaiye aracı, zorlu görevlerde çalışmaya uygun yapısı ve sağlam şasisiyle, %100 yerli mühendislik ürünü, yerli üretim belgesine sahip tek araç. Monoblok çift kabiniyle de personel ve ekipman için ferah kullanım alanı sağlayan 1833 her an hizmet vermeye hazır.

Ford Trucks
Her yükte birlikte

444 36 73 / 444 FORD
www.fordtrucks.com.tr



Ford

TRUCKS

11 December

- Turkey's economy grew by 11.1 % in the third quarter of the year.

- Turkish Statistical Institute: Exports reached

12 December

- President Recep Tayyip Erdoğan announced the disclosure of a support package for employers during the Employment Council

15 December

- Economy Minister Nihat Zeybekci stated that they are ready to announce an investment worth 70 billion TL in the project based incentive system and said "We will award an investment incentive certificate worth 70 billion TL to all investors at one time."

\$13.9 billion in October, rising 9 % year-on-year.

- In order to support domestic production, the tender documents will be prepared to ensure the use of domestic products in the public sector construction works .

-Turkey's trade deficit widened by 37.5 % in 2017 to \$77.1 billion

29 December

-Labour Minister Jülide Sarıeroğlu said minimum wage will be raised by around 14 % in 2018, for a monthly minimum wage of 1,603 liras (\$423.30).

31 December

-Turkish Statistics Institute (TÜİK) announced that in December 2017, TÜFE (CPI) rose by 0.69 % and Y-ÜFE (D-PPI) by 1.37 %.

OBLIGATION TO USE DOMESTIC GOODS IN CONSTRUCTION WORKS



In order to support domestic production, it has been obligatory to prepare tender documents in a way to enable the use of domestic products in the public sector's construction tenders.

A regulation has been rearranged in the tender legislation to introduce the obligation to use local goods in the construction works tenders within the framework of domestic production support policy through public sector tenders, after a recent arrangement of the commodity procurement tenders

In July, legislation was revised regarding the use of domestic machinery, materials, equipment and software in construction tender contracts.

With the subject arrangements, it is ensured that the specifications will be prepared in a way to bring the condition of supply of all or part of the machinery, materials, softwares and equipment to be used in the construction works.

The machinery, materials and equipment and other commodities, as listed with the decision of the relevant Ministry and Public Bidding Authority, should be locally supplied for use in the construction projects.

In the Regulation on the Amendment of the Regulation on the Implementation Regulations in Construction Works, as published in the Official Gazette dated 13 December 2017, tender specifications are to be prepared in consideration of the lists of domestic commodities (of those out of the technical reasons prepared by Ministry of Environment and of machines and equipment as prepared by Ministry of Science and Industry).

It is also stated that the tender documents should be prepared in such a way as to ensure the use of domestic products during the construction phase and that "the Regulation stipulates that tender documents of the administrations clearly state the conditions relating to the procurement of domestic products to be used in the scope of the tender and that, in the construction phase, building supervisors control the utilization of these products."

The construction tenders reached a volume of 80 billion TL in 2016, and the obligatory use of local products in such tenders could provide important contribution to the development of the domestic industry.



*Sağladığı Güven ve Tecrübe ile
Daima Sizinle...*

TEKNİK TANKER



KOCASINAN MERKEZ MAH. MİMAR SİNAN CAD. NO:14/2 İÇ KAPI NO:18 BAĞÇELİEVLER/İSTANBUL
TELEFON : +90 212 652 70 70 FAKS: +90 212 541 40 30 E-POSTA: info@tekniktanker.com.tr

CENTRAL BANK'S 2018 MONETARY & EXCHANGE RATE POLICY

The Central Bank will maintain its price stability-oriented monetary policy framework and inflation targeting will continue to shape the monetary policy regime in 2018, according to the Bank's *Monetary and Exchange Rate Policy for the 2018* report issued .



"Monetary policy decisions will be based on inflation expectations, pricing behavior and other factors that affect inflation," the bank said.

"Financial stability will also be considered while inflation is aimed to be kept close to the target," it said. The bank added that it will continue to cooperate with other institutions to remove structural impediments to lowering inflation.

Saying that its main objective is achieving and maintaining price stability, "to this end, the inflation target for the 2018-2020 period is set at 5 percent as per the agreement reached with the government," it said.

"In line with the Medium-Term Program, it is anticipated that inflation will gradually converge to the 5 percent target in 2018-2020," the bank said.

Below are the main highlights specified by the Central Bank to be followed in the new period:

As in 2017, the CBRT will continue to use liquidity tools with an appropriate composition and in a manner to support predictability in line with its objective of achieving price stability. Considering all possibilities in liquidity conditions; to be able to control interest rates at the BIST Repo-Reverse Repo Market and the Interbank Repo-Reverse Repo Market, to manage the funding need of the financial system, to preserve the instrument diversification for liquidity management and operational flexibility, the CBRT needs to maintain a sufficient

amount of GDDSs or TL-denominated lease certificates issued by the Asset Leasing Company of the Turkish Treasury (ALCTT) for technical reasons. Accordingly,

- ✓ Without prejudice to the additional purchasing option, the OMO portfolio, which was set as TL 15 billion nominal for 2017, is set as TL 16 billion nominal for 2018,



- ✓ Outright purchase operation of 6.8 billion TL nominal, including the TL 5.8 billion nominal to be redeemed in 2018, will be conducted in 2018,
- ✓ Outright purchase operations will be conducted in a balanced and predictable framework by taking into account the CBRT OMO portfolio redemption schedule, liquidity conditions in the market and internal borrowing program of the Undersecretariat of Treasury, and the securities to be purchased by the CBRT will be announced through data dissemination companies at 10:00 a.m. on the first working day of the respective month,
- ✓ Buying auctions will be held on Mondays, Wednesdays and/or Fridays with value the next business day, Each auction amount will be no more than a nominal of TL 150 million,
- ✓ Other issues related to the auctions will be subject to the existing regulations and may be changed if deemed necessary.

First PPK meeting

Turkey's Central Bank has also issued the calendar of meetings.

The first Monetary Policy Board Meeting of 2018 will be held on 18 January.



NESA

Taşıt Üst Yapım

Detaylara Önem Verir



NESA
Taşıt Üst Yapım

Merkez : Gersan Sanayi Sitesi 2310 Sok. No:41 Yenimahalle / ANKARA 06370
Fabrika : Saray Mahallesi Keresteciler Sanayi Sitesi 18. Sokak No: 18 Kazan / ANKARA
www.nesaustuyapim.com.tr

Telefon: +90 312 257 24 40 (Pbx)
Faks : +90 312 256 65 40 (Faks)
E-Mail : info@nesaustuyapim.com.tr

2018 INVESTMENT PROGRAM'S PROJECT VALUE 804.6 BILLION TL

The "2018 Annual Investment Program" prepared in line with the investment targets comprises a total of 3.212 projects with a project cost of 804.6 billion liras, cumulative spending of 308.2 billion liras and an allocation of 88 billion liras in 2018.

The Decision of the Council of Ministers on *the Implementation, Coordination and Monitoring of the 2018 Annual Program* was published in the doublet issue of the Official Gazette dated 15 January 2018.

Accordingly, the program was prepared in line with the targets set out in the Tenth Development Plan, in the Medium Term Program 2018-2020 and in the 2018 Program.

The "2018 Annual Investment Program" comprises a total of 3.212 projects with a project cost of 804.6 billion liras, cumulative spending of 308.2 billion liras and an allocation of 88 billion liras in 2018.

The investments in the "2018 Annual Investment Program" have been arranged on sectoral basis.

They will be carried out by Public administrations within the scope of general budget, public administrations within the scope of special budget, regulatory and supervisory institutions, economic state enterprises and public economic institutions with over 50 percent of public share and their subsidiaries, organizations under the scope of privatization, social security institutions, and projects to be realized by municipalities, institutions, revolving funds, Iller Bank, metropolitan municipalities using foreign project loans and by other municipalities.

The "2018 Annual Investment Program" comprises the amendments enacted by the Turkish Parliament during the process of debating the 2018 Central Management Budget Law Draft ...

Investment projects have been classified as "study project works", "ongoing projects" and "new projects". For each project, project number, name, location, characteristics, start and ending date, project amount, estimated amount of expenditure until the end of 2017 and 2018 payments are separately indicated.

Of the capital transfer appropriations in the Central

Government Budget Law of the year 2018, only those that are of public investment type are included in the sum of enterprise and sector investment allowance, and some of the transfers which are not public investment but of out- of –public- sector transfer type are not included in the sum of enterprise and sector investments and have remained associated with the 2018 Investment Program.

Investment allowances of public administrations within the scope of general and special budget, personnel expenses related to investments, real estate purchase and expropriation allowances and rental payments of city hospitals have not been included.

Investment allowances of public administrations within the scope of general and special budget do not cover personnel expenses related to investments, real estate purchase and expropriation allocations and rental payments of city hospitals.

Regulatory and supervisory agencies are included in the 2018 Investment Program for information on investment-grade projects, except for property acquisition and expropriation payments.

Within the scope of the "Support for the Infrastructure of Villagers Project (KÖYDES)" in the Central Government Budget Law of 2018, a budget of 900 million TL has been allocated in the related budget of the Ministry of Finance to be used for provincial special administrations and / or village service unions for rural infrastructure needs.

Within the scope of the Water Sewerage and Infrastructure Project (SUKAP) within the scope of the Central Management Budget Budget Act of 2018, 719 million 270.000TL appropriation has been reserved in the related budget of the budget of the Ministry of Finance to realize the drinking water and wastewater projects of the municipalities.

The subject allocation is not included in the sum of the investment program and its use will be realized within the provisions of the 2018 Central Management Budget Law.

The principles and procedures concerning the allocation, disbursement, monitoring and supervision of the allocation of this allowance for SUKAP on the basis of municipalities shall be decided by the High Planning Council.

2018 PROGRAM IMPLEMENTATION IN OFFICIAL GAZETTE

The Decision on the "2018 Program" and "Implementation, Coordination and Monitoring of the 2018 Program" was published in the Repeated Issue of the Official Gazette dated 28 October 2017.

Accordingly, the implementation, coordination and monitoring of the legal and institutional arrangements in the 2018 Program will be carried out in line with sectoral programs, priority action programs, economic, social and regional development policies and related investments and measures at every echelon of the relevant ministries and agencies, as per the appropriate study schedule.

In this context, it will be ensured that the projects that will be prepared in accordance with the priorities as included in program and strategy documents prepared for conformity to the EU as well as the National Program of Turkey for Undertaking the EU Acquis, the Strategic Framework Document, and the Indicative Strategy Document for Turkey (2014-2020), to be financed by the EU funds, are compliance with the 2018 Program and the investment program integrity of national contribution to be provided by Turkey.

Legislation, administrative decision and financing, which will be needed in the implementation of action plans for priority transformation programs, will be given priority by all the public institutions and organizations. In the implementation of the 2018 Program, the basic principle will be that investments are not to be changed or their budgets not transferred and that macroeconomic targets be taken into consideration and balances among sectors and regions not be disrupted.

No spending on the projects not included in the program

The implementation of the 2018 Investment Program will be based on the priorities of the Tenth Development Plan, the Medium Term Program (2018-2020) and the 2018 Program.

The additional financing requirements of the projects involved in the program will be met primarily through transfers from the allocations to the other projects, in accordance with the principles set out in this decision. Organizations will have to limit any additional funding demands relying on their urgent and compulsory needs, taking into account their budgetary opportunities. No expenditure will be made for any projects not included in the program. Projects will be associated with the

investment program regardless of the source of funding (including grants, land pledges and the like).

The Ministry of Finance and the Undersecretary of Treasury will take the necessary measures to ensure that the Annual Program financing needs are met on time, taking into account the construction season, and that the necessary resources are transferred to the appropriate institutions that are convenient to the expenditure programs. All transactions such as investment project proposal related to public investment program processes, determination of sub-projects, revisions of the project parameters including additional financing demand, cost increase and allocation change, notification of expenditure data, will be executed through the Public Investments Informatics System (Ka-Ya).

The investment program will be settled by the Supreme Planning Council is authorized to review, for inclusion into the Investment program, the demands for Projects that cost more than 100 million TL, or Development ministry approval will be required for those whose cost is up to 100 million TL or those which will be completed in the year with 100 mln TL expenditure regardless of their costs. Demands for project exclusion from the program for those whose cost is up to 100 mln TL will be concluded with the approval of the Ministry of Development, and those whose cost is over 100 mln TL will be handled by the Supreme Planning Council (YPK).

Allocation changes

Allocation of additional allowances up to a total of 100 million liras to be made during the year (including sub-projects of aggregated projects) from any sources will be handled with the Development ministry approval, and the additional allocations exceeding this amount on project basis will be settled by the YPK. However, the amount of funding realized on revolving capital revenues and the estimated income amount specified in the Budget Law of the budgetary institutions and the local revenue transferred from the previous year shall be included in the Investment Program with the approval of the minister with which the institution is affiliated, the rector of the university and the higher manager of the other institutions, for being associated with projects.

The project revision requests can be sent to the Ministry of Development by December 15, 2018 and the requests will be finalized by the end of the year.

EXPORTS REACHED \$157.1 bn VALUE IN 2017

The Turkish Exporters Assembly (TİM) announced Turkish export figures for 2017. For Turkish exports, 2017 was a lucrative year, recording the second highest figure in the country's history and generating \$157.1 billion. The figure was particularly boosted by six sectors.

Six sectors broke record off all time last year

According to the data of the Turkish Exporters Assembly (TİM), the automotive, machinery, jewelry, defense and aviation, fruits and vegetables and ornamental plants sector reached their highest annual levels in exports.

TİM Chairman Mehmet Büyükeksi noted that exports in 2017 increased every month without exception and recalled that the increase in exports was in double digits in eight months of the year. Büyükeksi said the automotive, machinery, jewelry, defense and aviation, fruits and vegetables and ornamental plants sectors reached their highest annual export levels.

Automotive again the pioneer of exports

The automotive exports, which stood at only \$2.4 billion in 2000, reached the highest all time level with \$28.5 billion in 2017, while in the same period, the machinery sector reached an all-time high with \$6.1 billion, followed by the jewelry sector with \$3.3 billion, the defense and aviation sector with \$1.7 billion, the fruits and vegetables sector with \$1.4 billion and the ornamental plants sector with \$85 million.

Meanwhile, the provisional data revealed that the unit price of exports in 2017 was \$1.36.

Turkey recorded the second-highest export volume in the republic's history with \$157.1 billion in 2017, according to provisional data of the Ministry of Customs and Trade. Turkey's exports reached \$157.1 billion in January-December 2017, marking an increase of 10.22 percent, the ministry's data bulletin showed.

Turkey's highest export figure was recorded in 2014 with \$157.6 billion, according to official data.

The export figure came after Turkey's highest growth performance in three quarters of 2017.

The country's economy expanded beyond forecasts in the first quarter (5.3 percent) and second quarter (5.4 percent) of this year, according to TÜİK.

Turkey became the fastest-growing economy among G20 countries with its unexpectedly high 11.1 percent growth in the third quarter of 2017. The report said the import of the country rose by 17.92 percent to \$234.2 billion in the period. Turkey's foreign trade volume accounted for \$391.3 billion, rising 14.70 percent in January-December 2017. The foreign trade deficit of the country annually increased by 37.5 percent in the same period, accounted \$77.06 billion.



November Exports Up by 11.2 Percent

Turkey's exports increased by 11.2 percent in November, reaching \$14.21 billion, while exports went up 21.3 percent to reach \$20.54 billion, the Turkish Statistical Institute (TÜİK).

TÜİK also said the foreign trade deficit rose 52.4 percent in November, amounting to \$6.3 billion.

The rate of exports meeting imports, meanwhile, fell to 69.2 percent compared to 75.5 percent in November 2016. Despite currently frosty relations between Ankara and Berlin, Germany was Turkey's top trading partner in November in terms of both imports and exports. Exports to Germany stood at \$1.38 billion, while imports from the country reached \$1.98 billion. Turkey's exports in the first 11 months of 2017 amounted to over \$143.2 billion — a 10.4 percent rise compared with the same period in 2016, TÜİK said.

The new year will be more successful than 2017

President of the Turkish Exporters' Assembly (TİM) Büyükeksi said that Turkey will break previous export records by crossing the medium-term program's \$169 billion target in 2018, the country's largest exporters' association said.



FIAT PROFESSIONAL İŞTE SAĞLAM ORTAĞIN

Her ihtiyaca uygun tasarlanmış Fiat ticari araçlar,
şimdi Fiat Professional markasıyla işinizi ileri taşıyor.
Fiat Professional ailesiyle ticaret güçleniyor!

İşte sağlam ortağın. **Fiat Professional.**

Büyükeksi said they prepared a roadmap to exceed the targets.

"The support from the government and the recovery of the global economy was reflected on our exports," he said.

He added that the government's export target for 2017 was \$153.3 billion and it had been revised to \$156.5 billion.

"We expect that Turkey's exports will rise over 10 percent to \$14 billion in December and we will overtake this target by reaching \$157.3 billion," he said.

Turkey's exports amounted to \$13.6 billion in November and \$142.7 billion in the first 11 months of 2017, according to TIM's data. Early November, Turkish Economy Minister Nihat Zeybekci had said the country is expected to exceed its revised export target of \$156.5 billion by the end of 2017.

He expressed that exports reflect Turkey's growth, calling on international ratings bureaus to revise Turkey's growth estimate figures.



Exports to 33 countries in 23 sectors exceed 1 - billion -dollar limit

TİM President said Turkey's exports to 185 destinations increased in 2017, noting that they reinforced their presence in many countries in this period regardless of their proximity.



Noting that their exports to Iceland went up more than six-fold, followed by Haiti with a four-fold increase, Büyükeksi said the exports to Jamaica, Malta and Panama rose by over 100 percent, while exports to

Liberia, Singapore and the Dominican Republic almost doubled.

,"With the crisis that we experienced with Russia now left behind, we reached an increase of 51.2 percent in exports to Russia this year," he added.

Büyükeksi stated that even though the top 20 countries that Turkey exports to the most remained unchanged in 2017, the ranking slightly changed. Noting that the top three are Germany, the U.K. and Italy respectively, Büyükeksi said the U.S., which ranked fifth last year, rose to fourth place this year with the increase in automotive exports, while China ranked fifteenth, rising three places in a row.

"Countries such as Israel, Romania, Bulgaria found their place in higher ranking this year. In the top 20, we got the highest export increase in Russia," Büyükeksi continued, adding that exports to Spain, the U.S., China and Belgium increased by more than 20 percent, while double digit increases were achieved to the U.K., Iraq and Poland.

Rise in global trade affects exports positively



Büyükeksi pointed out that they expect global trade to reach \$ 16.5 trillion this year.

Second, the support of the government gave them strength; support for R & D and Design Centers, support for membership in E-commerce sites, green passport, increase in Eximbank's capital, financing and employment provided by KGF's companies.

"Thirdly, as TIM, we set our priorities well in exports and created our strategies in this frame," he noted, adding, "As is the case every year, this year we gave special importance to value added exports.

Our activities such as Innovation and Entrepreneurship Week, Design Week, which we organized, served this purpose.

We will continue to make all these efforts this year, too. "

KARBA®

OTOMOTİV MAKİNA SANAYİ VE TİCARET LTD. ŞTİ.
AUTOMOTIVE MACHINE IND. AND TRADE LTD. CO.

Güven ve İstikrarın Buluştuğu Adres



İtfaiye Araçları — Çöp Toplama Araçları — Vidanjörler — Basıncılı Su Kanal Açma Araçları — Kombine Kanal Açma Araçları — Hidrolifler
Dampner ve Dorseller — Su Tankerleri — Cenaze Araçları — Ambulanslar — Hidrolik Platformlar — Özel Üretim Araçlar



A : 1. Organize San. Blg. Oğuz Cd. No:53/2 06935 Sincan- Ankara - TURKEY
T : +90 312 267 27 00 (pbx)
F : +90 312 267 49 60
E : info@karba.com.tr

Turkey
Discover
the potential

B.B.A - KARBA



www.karba.com.tr

KANAL İSTANBUL PROJECT'S ROUTE UNVEILED

Kanal Istanbul Project route will follow the Küçükçekmece-Sazlıdere-Durusu corridor, the fourth alternative for the project, was chosen as the most convenient route. The 45-km route will enter Küçükçekmece Lake and reach the Black Sea through the Sazlıdere Dam from east of Terkos Lake.

Transport, Maritime Affairs and Communications Minister Ahmet Arslan unveiled the final route of the Kanal Istanbul Project, a canal parallel to the Bosphorus that is planned to connect the Black Sea and Marmara Sea. The Project had been announced by President Recep Tayyip Erdoğan first in 2011.

Minister Arslan said, "We intend to complete the bidding process with a mixed model, including a build-operate-transfer model, and other public-private partnership alternatives, and to launch the project this year,"



Arslan said the first target in the project of making a new waterway connecting the Black Sea with the Marmara Sea on Istanbul's European side is to reduce the ship traffic on the Bosphorus in Istanbul.

Explaining that the target is to reduce the risks that could arise from vessels carrying dangerous substances through the Bosphorus and to provide a more modern life to the people who live in that area by carrying out urban transformation projects on the waterway route and removing irregular urbanization, Arslan said the third goal is to increase both the position and attractiveness of Turkey with waterway transportation in Istanbul. The canal is expected to have capacity for 160 vessels a day and is scheduled to be completed by 2023.

Arslan said that all the work carried out by the ministry's Infrastructure Investments Dept. and related institutions and organizations were evaluated and that

bidding for the preparation, project and consultancy services were held last year, adding that the work was initiated in August 2017.

Minister Ahmet Arslan Announces Route Details

Arslan said that all work, including the determination of alternative routes, evaluation of the current situation, numerical model studies, earthquake, tsunami, wind and wave climate and geological surveys were completed by the beginning of the year, explaining that each topic was handled in detail. Arslan said that they received support from experts who specialized and active in their fields from Turkey's leading universities such as ITÜ, Boğaziçi University, ODTÜ and Gazi University, as well as international experts. "Taking into account the feasibility within the framework of various elements such as mine, site and sensitive areas, geological studies, underground and surface water resources, soil resources, effects on maritime and transport networks, splitting volume, channel length, expropriation and effects on residential areas, studies continued on five routes," Arslan said.

According to numerical modeling studies, he said the preliminary models that will be the basis of the basic survey study was completed. He said groundwater currents along the project route were detected, adding that different types of earth were identified, and the permeability of each was determined to be different.



Noting that their work is carried out more precisely in the determined corridor in order not to adversely affect the ground water, Arslan said they will continue working more sensitively on the identified alternative.

He said that all studies were done taking into account earthquake risks and the average recurrence of 72 years, 475 years and 2,475 years. "All of these projects will continue to be evaluated together, including the project areas, which can be used as a logistics center, and the artificial islands that can be made by filling the Marmara Sea with the filling material to be produced in the Black Sea," Arslan said.

KAMYONUN İYİSİ ATLAS'IN YENİSİ



Az Yak
Az Öde

Yokuşu
dert etme



Yeni Nesil
Euro 6 Motor



Düşük Yakıt
Tüketimi



Yokuş Kalkış
Desteği



Hız
Sabitleyici



Şerit Takip
Sistemi



Elektronik
Denge Kontrolü



8,5 Ton
Azami Yüklü Ağırlık



Tam Havalı
Fren Sistemi

Yenilenen Atlas, işinize güç katmak için yola çıkıyor.

Yeni nesil Euro 6 motorlu Atlas, Yokuş Kalkış Desteği (HSA) ile güvenliğinizi artırıyor. Hız sabitleyici, ergonomik direksiyon ve yenilenen iç kabin ile konforlu bir sürüş sunuyor. Yeni şasisiyle her türlü üst yapıya uyum sağlıyor.

Hemen bir Otokar Yetkili Satıcısı'na gelin.
Yenilenen Atlas'la tanışın, alırken kazanın.

Yenilenen iç kabin.

HSA (Yokuş Kalkış Desteği)

☎ 444 6857 [444 OTKR] 🌐 www.otokar.com.tr 📱 /OtokarTicariAraclar 📺 /OtokarAS 📺 /OtokarTr

Koç

FOTON

Otokar
— Doğru karar —

TÜİK ANNOUNCES DECEMBER INFLATION FIGURES

■ In December 2017, TÜFE (CPI) rises by 0.69 % and Y-ÜFE (D-PPI) by 1.37 %...

■ On annual basis, inflation in TÜFE becomes 11.92 % and in Y-ÜFE 15.47 %...

The Turkish Statistics Institute (TÜİK) has announced the December 2017 inflation figures as follows:

Domestic producer price index increased by 1.37 %

Domestic producer price index (D-PPI) increased by 1.37% on monthly basis, by 15.47% on December of the previous year basis, by 15.47% on same month of the previous year basis and by 15.82% on the twelve months moving averages basis in December 2017.

D-PPI increased by 1.91% for mining and stone quarrying, by 1.34% for manufacturing, by 1.67% for electricity and gas and by 0.27% for water supply compared with the previous month.

The highest monthly increase was in crude petroleum and natural gas

The highest rates of monthly increase in D-PPI by sub divisions of industry were index for crude petroleum and natural gas by 15.32%, for basic metals by 3.29%, for motor vehicles, trailers and semi-trailers by 2.72%. On the other hand the highest rates of monthly decrease in D-PPI by sub divisions of industry were index for metal ores by 1.58%, for wearing apparel by 0.33% and for coal and lignite by 0.07%.

According to main industrial groupings classification in December 2017, the highest rate of monthly increases was in energy goods and the highest rate of annual increases was in intermediate goods.

Consumer price index (CPI) up by 0.69%

A rise in general index was realized in CPI (2003=100) on the previous month by 0.69%, on December of the previous year by 11.92%, on same month of the previous year by 11.92% and on the twelve months moving averages basis by 11.14% in December 2017.

The highest monthly decrease 2.39% in clothing and footwear

In December 2017, the indices rose for food and non-alcoholic beverages 1.52%, for furnishing and household equipment 1.18%, for housing 0.77% and for hotels, cafes and restaurants 0.47%.

In December 2017, the indices declined for communication 0.17% and for alcoholic beverages and tobacco 0.01%.

Food and non-alcoholic beverages with 13.79%, miscellaneous goods and services with 12.77%, furnishing and household equipment with 12.74% and health with 11.90% were the other main groups where high annual increases realized.

The highest monthly increase 1.52% in TRC3 (Mardin, Batman, Şırnak, Siirt)

The highest increases in CPI were recorded in TRB2 (Van, Muş, Bitlis, Hakkari) region with 13.59% compared with the same month of the previous year and in TRC1 (Gaziantep, Adıyaman, Kilis) region with 12.79% on the twelve months moving averages basis.

Cemil Ertem: The actual correction in inflation in the first quarter.

Meanwhile, Presidential Chief Economist Cemil Ertem said that annual inflation was on a downward trend with December, but the actual correction would be caught in the first quarter of the year with about 200 base points. "We started to experience a downward correction in December after the summit we saw in inflation, and we will catch the real correction in the first quarter," he said.

According to some analysts, high core inflation is actually worse than high headline inflation, as the former can mainly be eased by monetary policy tools.

"Core inflation does not include volatile items, like energy or food. Therefore, it is becoming more and more difficult to fight against this," said SPINN Consultancy Co-Founder and academic Özlem Derici Şengül.



ALTINOK

MÜŞAVİRLİK MÜHENDİSLİK A.Ş.

Ticaret Sicil No: 222441-170001



**MÜHENDİSLİK VE MÜŞAVİRLİK HİZMETLERİNDE
YETKİNLİK, ETİK VE BAĞIMSIZLIK UNSURLARIYLA
54. YIL (1963-2017)**

Seyrantepe Mah. İ.Karaoğlanoğlu Caddesi ALTINOK PLAZA No:37 Kat 1 34418 KAĞITHANE / İSTANBUL

TEL: +90 - 212 - 221 44 08 Faks: +90 - 212 - 221 44 09

www.altinok.com.tc info@altinok.com.tc

ANNUAL INFLATION FIGURES (%)						
	D-PRODUCER			CONSUMER		
MONTHS	2015	2016	2017	2015	2016	2017
January	3.28	5.94	13.69	7.24	9.58	9.22
February	3.10	4.47	15.36	7.55	8.78	10.13
March	3.41	3.80	16.09	7.61	7.46	11.29
April	4.80	2.87	16.37	7.91	6.57	11.87
May	6.52	3.25	15.26	8.09	6.58	11.72
June	6.73	3.41	14.87	7.20	7.64	10.90
July	5.62	3.96	15.45	6.81	8.79	9.79
August	6.21	3.03	16.34	7.14	8.05	10.68
Septem.	6.92	1.78	16.28	7.95	7.28	11.20
October	7.59	2.84	17.28	7.86	7.16	11.90
Novem.	5.25	6.41	17.30	8.10	7.00	12.98
Decem.	5.71	9.94	15.47	8.81	8.53	11.92

MONTHLY INFLATION FIGURES (%)						
	D-PRODUCER			CONSUMER		
MONTHS	2015	2016	2017	2015	2016	2017
January	0.33	0.55	3.98	1.10	1.82	2.46
February	1.20	-0.20	1.26	0.71	-0.02	0.81
March	1.05	0.40	1.04	1.19	-0.04	1.02
April	1.43	0.52	0.76	1.63	0.78	1.31
May	1.11	1.48	0.52	0.56	0.58	0.45
June	0.25	0.41	0.07	-0.51	0.47	-0.27
July	-0.32	0.21	0.72	0.09	1.16	0.15
August	0.98	0.08	0.85	0.40	-0.29	0.52
Septem.	1.53	0.29	0.24	0.89	0.18	0.65
October	-0.20	0.84	1.71	1.55	1.44	2.08
Novem.	-1.42	2.00	2.02	0.67	0.52	1.49
Decem.	-0.33	2.98	1.37	0.21	1.64	0.69

MERCEDES-BENZ TÜRK MARKS GLOBAL ACHIEVEMENTS IN ITS 50TH ANNIVERSARY

Closing the year 2017 successfully once more, Mercedes-Benz Türk has evaluated the automotive sector in 2017 and forecasts of 2018.

Mercedes-Benz Türk, which started operations in 1967 with the brand name *Otomarsan*, has today exceeded a turnover of 1 billion euros and thus it has become one of Turkey's largest foreign-owned companies. Mercedes-Benz Türk has continued its achievements in the Turkish truck market in 2017, when it has celebrated its 50th foundation anniversary in the industry. Mercedes-Benz Türk A.Ş. reached a value of 1,138 billion euros spent on the investments for half a century. The company realized sales of 423 units of buses, 9.128 units of trucks, 9.041 units of light commercial vehicles, and 25.588 units of automobiles in 2017. The second hand vehicle sales reached 4.598 units in total. Thus a total of 48.778 units of vehicles were sold all year in the face of challenging conditions.



Mercedes-Benz Türk's Hoşdere Bus Factory continued its productions despite adverse conditions, and produced 3.795 units of buses in 2017. Exporting about 90% of its production to West European countries, its bus export figures rose to 3.396 in 2017. The company's bus export volume has reached a total of 50.120 units since 1970 when the first export was made. Since 1968 when the first bus production started, Mercedes-Benz Türk has produced a total of 84.865 ea buses.

Mercedes-Benz Türk, whose first truck was launched off line in 1986, maintains its traditional leadership position in the truck market with trucks and trailers manufactured in the Aksaray Truck Factory. It has produced 246.147 units trucks since then.

The Aksaray Truck Plant produced 13.393 trucks in 2017 and the export volume of trucks increased by 38% compared to 2016, reaching the highest export figure of its history with 6.469 units truck exports. The total number of its truck exports has reached 43.738 since 1986.

In the Light Commercial Vehicle Group, the company was among the first two brands to reach the highest sales figures. The Mercedes-Benz Automobile Group also maintained its prominent position in the premium car segment and retained it in 2017.



Mercedes-Benz Türk Board of Directors President Süer Sülün:

President of the Board of Directors of Mercedes-Benz Türk Süer Sülün, stating that the year 2017 when Mercedes-Benz Türk celebrated its 50th anniversary was an important milestone for the company, said, "Without losing our belief in the Turkish market in 2017 we continued to offer new products to our market. Through our motivation because of our company's 50th anniversary enthusiasm we have preserved our traditional leadership as a result of our team work."

Sülün also said, "We are proud of the superior performance, history and tradition Mercedes-Benz Türk has shown for half a century. Despite the challenging conditions in the market in Turkey in 2017, we managed to maintain our leadership and intercity buses and trucks that has become traditional in the market. We focused on exports due to the decrease in domestic demand at the Hoşdere Bus and Aksaray Truck Factories and we continued our productions at the levels we had planned."

"Investments made in the Aksaray Truck Factory in 2016 started to give fruits in 2017 and Mercedes-Benz Türk's truck exports rose by 38 percent, reaching the highest export figure of all times. Our investments continued in 2017 as well. We realized the groundbreaking ceremony of the new R&D Center in May 2017 to be established with an investment of 8.4 million euros at the Aksaray Truck Factory." Sülün added.

Mercedes-Benz Light Commercial Vehicles Executive Committee Member Tufan Akdeniz:

Mercedes-Benz Light Commercial Vehicles Executive Committee Member Tufan Akdeniz, evaluating the year 2017, stated that they were among the top two brands that reached the highest sales figure in 2017.



"Turkey and light commercial vehicle market, recorded a growth of 2.9 percent last year compared to 2016 while the comparative light commercial vehicle market experienced a 1.7 percent expansion. Our Mercedes-Benz Türk Light Commercial Vehicles Group succeeded in raising the total sales in this area by 9 percent. As Mercedes-Benz Türk, we sold 9.041 units of light commercial vehicles in 2017, including *X-Class*, which we launched recently."

"Vito, with its low initial purchase cost, high quality standards, fuel economy, increased safety equipment, wide range of products suitable for different uses, reached the ever highest sales figure in 2017 with sales of 4.159 units. In our *Sprinter* vehicle segment, which has an important place in transportation of students and personnel as well as tourists and passengers in urban areas, we realized 4.644 unit sales."

"In 2017 we launched the 30.000th Sprinter minibus, which, since 2007, has been produced with the efforts of Turkish engineers and workers, under the cooperation of Mercedes-Benz Türk and Arobus. Another important development for the light commercial

vehicles group is that we logged into the pick-up segment in 2017, and we put on sale the curiously awaited X-Class Mercedes-Benz vehicle in Turkey in December. We sold 238 X-Class units within a month, making Mercedes-Benz the number one selling X-Class in global sales"



Mercedes-Benz Türk Hoşdere Bus Factory's production underway uninterruptedly

Meanwhile, Mercedes-Benz Türk's Hoşdere Bus Factory continued its productions despite adverse conditions, and produced 3.795 units of buses. *Travego*, *Tourismo*, *Conecto*, *Intouro* and *Setra* brands produced at the facilities are being exported to more than 70 countries. *Tourismo* is being renewed in 2018. Mercedes-Benz Türk reached a sales figure of 423 units in 2017 in the bus group despite tough competition environment.



Mercedes-Benz Türk Aksaray Truck Factory with higher capacity

Mercedes-Benz Türk has started to buy new fruits of the investment made in 2016 in Aksaray Truck Factory. With the new R&D Centre, the Aksaray Factory will convey all the research and development services to the whole world. The company has reached its target in truck group in 2017 and realized sales of 9.128 units.

BAŞTAN SONA ETKİLEYİCİ: ZF'DEN KOMPONENTLER VE SİSTEMLER

Otobüs yolcuları maksimum güvenlik ve konfor bekler. ZF'nin şanzımanları ve aksları bu beklentilerin karşılanmasına yardımcı olmaktadır. Ürünlerimiz yolcuların araca hızlı ve güvenli bir şekilde inip binmelerini, güvenli ve keyifli bir yolculuk yapmalarını sağlıyor. Dahası, ZF ürünleri birbirlerine tam olarak uyumludur ve en üst düzey teknolojiyle geliştirildikleri için dinamik hızlanma ve aynı zamanda sessiz çalışma özelliklerine sahiptir. ZF komponentleri ile aracınızın hem kullanım ömrü maliyetlerini hem de araç ve çevre üzerindeki olumsuz etkileri azaltabilirsiniz. www.zf.com/buses



MOTION AND MOBILITY

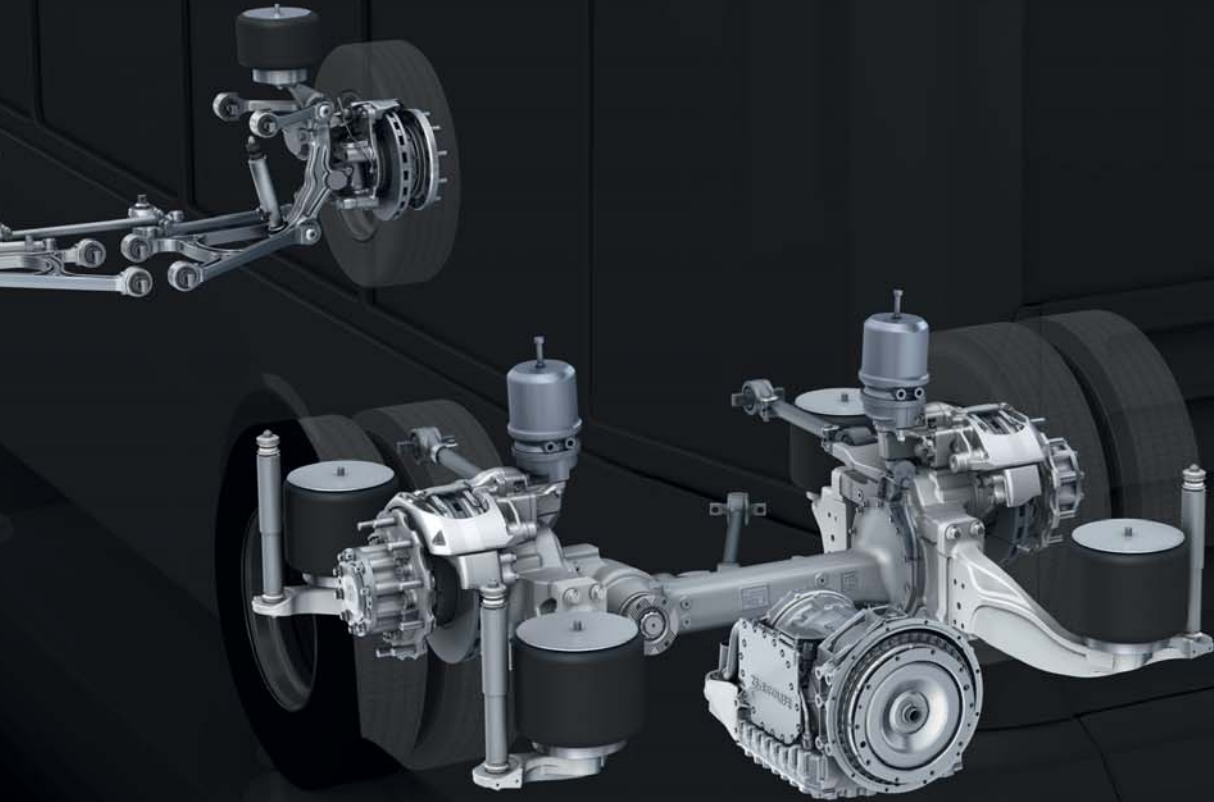

FORD TRUCKS HAS DOUBLED ITS MARKET SHARE IN THE LAST TEN YEARS

Ford Trucks, raising its market share two-fold in the last 10 years, continued to attract the attention in 2017 with its new models and services, as well as in the field of domestic and foreign dealership restructuring and heavy commercial competition.

Ford Trucks has doubled its market share with new product and motor technology investments over the past 10 years, 4S plant infrastructure investments, service offerings and product development capabilities for customer expectations. In 2017 Ford Trucks, which has completed the number of domestic 4S facilities in 30, reached 33% in the construction segment and 27.7% in the overall market.



In 2017, Ford Trucks increased its sales in overseas markets by 50% with 8 new 4S facilities opened in Romania, Hungary, Bulgaria, Egypt, Croatia, Israel, Georgia and Ghana.

Serhan Turfan: "We reached 33% market share with our strong products in the growing construction segment."

Serhan Turfan, who had been in the post of Director of Ford Trucks Turkey since 2014, has been appointed as the Deputy Chief Executive Officer in 2018, made an evaluation of the heavy commercial vehicle market and domestic brands and overseas operations, during the 2017 evaluation meeting.

Turfan, pointing out that the heavy commercial vehicle market was completed with a similar volume to that achieved in 2016, said, "The year 2017 was a year

of prevailing big changes in the market as experienced before.

The trailer segment, which normally constitutes an average of 60% of the market, declined to 38% in last year, while the construction segment doubled with large construction projects in the market. The increase in the construction segment was a great opportunity for us with the right product investments we made and the appreciation of our products by our customers and we achieved a 33% market share in the construction segment. We reached 27.7% market share in the overall market and we managed to double our market share thanks to the right moves we have made since 2008. In 2017, we continued our product investments in the context of our customers' requirements."

He stated, "With the raised loading capacity, our 8x4 construction truck 4142XD, which we have developed in accordance with the heavier working conditions has carried out much more work in less time, and we supplied our trailer 3542T with a new lightweight mixer and concrete pump suitable for tough construction site conditions, with high chassis strength, as well. In the giant projects of Turkey such as the 3rd airport Project, North Marmara Motorway bridge and Çanakkale bridge, we are taking our place with approximately 1,000 trucks."Turfan added, "With our TruckMarket operations, which provide expertise, financing, guarantee and rental services in the 2nd hand market, we achieved an important momentum and we swapped 1,000 vehicles."

"Our sales upwards by 50% in international markets in 2017"

Speaking about the achievements and targets in international markets, Turfan also said that they opened 8 ea 4S facilities in 2017 with the new markets entered. "In 2017, we entered Romania, Hungary, Croatia and Israel markets in the European region which is very important for our export operations."

"We expanded to Egypt and Ghana last year apart from Algeria and Morocco. Most of our structuring in the Middle East had been completed by 2016. In 2017, we launched our satellite installations in Saudi Arabia and Iraq. In 2017, we launched the opening of our Georgia facility in the region of Turkic Republics.

EMMS

Emergency Mobile Systems

AMBULANCES



EN 1789:2007+A2:2014

MOBILE HEALTH CARE VEHICLES



ISO 9001 ISO 13485

TS EN 1789+A2 TS EN 1865-1+A1



Gost-R



MERKEZ

1.Organize Sanayi Bölgesi Kırım
Hanlığı Cad. No: 9 06930
Sincan/Ankara/TURKEY
Tel : + 90 312 589 88 88
Fax : + 90 312 267 18 66

ALMANYA ŞUBE / BRANCH GERMANY

Kalkumer Straße 125
40468 Düsseldorf Germany
Tel : +49 (0)211 / 680 20 53
Fax : +49 (0)211 / 680 20 55

İSTANBUL ŞUBE / BRANCH ISTANBUL

İstoç Toptancılar Çarşısı 28. Ada No:48-50
Mahmutbey/Bağcılar/İstanbul/TURKEY
Tel : +90 212 659 22 87 / 659 22 88
Fax : +90 212 659 22 89

DUBAİ ŞUBE / BRANCH DUBAİ

P.O. Box 261410 Dubai / U.A.E.
Tel : + 971 4 880 64 68
Fax : + 971 4 880 64 86

In addition, we decided to realize a new dealership in Russia. We increased our sales in international markets by 50% compared to the past." he said.

Meanwhile, speeding up with new inaugurations of agents in the country and abroad, Ford Trucks opened Nas Bayii that serves in the fields of sales, spare parts, second hand vehicles in Mardin. Koç Holding's Vice Board of Directors Vice President and Ford Otosan Board of Directors President Ali Y. Koç said during the opening ceremony, "With the opening we have realized today, the number of 4S service plants has reached 29. We are going further with Ford Trucks and we aim to appear in 50 countries by the year 2020."

"Ecotorq motors developed with 100% Turkish engineering contribute much to our achievements"

Tufan stated, "Ecotorq motors, developed with 100% Turkish engineering, contributed much to our achievements in the growth and success of Ford Trucks in the international market, as well as in Turkey. Trucks with Ecotorq engines were launched on roads in China, the world's largest truck market, under the license agreement we made with the Chinese JMC brand.

We are also happy to have received the "Chinese Truck of the Year" award for this Truck equipped with Ecotorq engine developed by Ford Otosan engineers"

2017 year of digitization

Ford Trucks also took important steps in the field of digitization in 2017 with its new website, *Asistanım* and *Yolunuza Sağlık* applications.

Ford Trucks with new managing staff

Ford Trucks welcomed the new year with a new management structure. Serhan Turfan has been appointed Deputy Chief Executive Officer in Ford Trucks after retirement of Ahmet Kınay. Emrah Duman is continuing to fulfill the post of Director of Ford Trucks International Markets, and Burak Hoşgören has been appointed Director of Ford Trucks Turkey.

M. Armağan Hazar has been appointed as the Czech Country Manager of Ford Trucks, and Bahattin Topçu as Ford Trucks Marketing and Strategic Planning Manager. Aysan Hoşver has been appointed as Manager of Ford Otosan İnönü Factory .

FOREIGN TRADE DEFICIT \$76.7 bln IN 2017

According to the provisional data, produced with the cooperation of the Turkish Statistical Institute and the Ministry of Customs and Trade, in December 2017; exports were 13 bln 878 million dollars with a 8.6% increase and imports were 23 bln 84 million dollars with a 25.4% increase compared with December 2016.



In December 2017 foreign trade deficit was 9 bln 206 million dollars with a 63.5% increase compared with December 2016. In December 2017, exports coverage imports was 60.1% while it was 69.4% in December 2016.

Seasonally and calendar adjusted exports and imports increased by 1% and 12.2%, respectively compared with previous month. Calendar adjusted exports and imports increased by 11.8% and 29.6%, respectively compared with December 2016.

Exports to the EU up by 15,6 %

As compared with the same month of the previous year, exports to the EU-28 increased by 15.6% from 5 bln 657 million dollars to 6 bln 540 million dollars.

The proportion of the EU countries was 47.1% in December 2017 while it was 44.3% in December 2016.

In December 2017, the main partner country for exports was Germany with 1 bln 308 million dollars. The country was followed by the United Kingdom with 827 million dollars, Italy and Iraq with 771 million dollars.

The top country for Turkey's imports was Germany with 2 billion 191 million dollars.

The country was followed by China with 2 bln 122 million dollars, Russia with 1 bln 884 million dollars and USA with 1 bln 164 million dollars. Foreign trade by technology intensity covers the manufacturing industries' products in classification of ISIC Rev.3.

OTOKAR MAINTAINS ITS LEADERSHIP IN 2017...

The prominent commercial vehicle producer Otokar held a press meeting at which the year 2017 was evaluated along with the expectations from the new year.

Otokar's press meeting was attended by Otokar's high ranking managers **Basri Akgül, Murat Tokatlı, Tarkan Burak and Murat Torun.**



The meeting focused on the evaluation of the bus market, in which the widest part of Otokar's product range took place, as well as on the evaluations of the semi-trailer market with the distribution and service truck Atlas and Otokar's Fröheauf Brand.



Otokar, one of Koç Group companies, has reinforced its leadership in the bus sector. With different lengths of 7 up to 18.75 meters Otokar has the widest product range in Turkey. Deputy General Manager Basri Akgül, Domestic Market Commercial Vehicle Sales Director Murat Tokatlı, Otokar Marketing Manager Tarkan Burak, Otokar Domestic Market Commercial Vehicles Bus Sales Manager Murat Torun and Otokar's high-level executives participated in the meeting when the year 2017 was evaluated and the 2018 objectives were disclosed. Otokar, which has to date signed many firsts in the sector with its studies in the field of R&D, Industry 4.0 and digital transformation as well as the buses it has produced based on its 55-year experience, became Turkey's most favourable bus brand.

"Small and Medium Size Bus Market Up By 12 Percent

Otokar's Deputy General Manager Basri Akgül said that the bus market, which has been declining for the last 3 years, increased 4% in 2017 compared to 2016.

He said, "As Otokar, we have added new innovations to our success as Otokar. 2017 was a year full of innovations, efficiency for Otokar. The best growth in the market took place in the sector of small and medium sized buses. While the sector grew 4 %, the small and medium bus segment achieved 12 % growth. A significant portion of the sales in 2017 occurred in municipal bus sales and small bus segments. In 2017, Otokar realized a total of 488 ea bus sales and became the leader with a market share of 28% in the (25-passenger and over cap.) bus market." Akgül pointed out that 1 out of every 3 vehicles sold in the areas where they operate was Otokar brand. In the small and medium sized bus segment in which the most product sales took place in the bus market, two of every 5 buses were Otokar branded.

"New Breath into The Sector"

Akgül noted that, with the power gained from their R&D studies, Otokar launched different vehicles for the market in a short time based on the evaluation of user expectations and needs both in the country and abroad,

Akgül said, "The market requirements in the transportation sector are changing almost every year."



Akgül added that Otokar also promoted the new service and tourism bus *Poyraz* last year along with renovation of Sultan series and Doruk T, with the improvement of Sultan LF upon demand from customers "We are continuing to invest so as to develop products in a way to be able to meet expectations" .

"Our new buses have been highly acclaimed in recent years for their innovative designs, especially for low fuel consumption expectations, maneuverability, performance, handling, advanced technical and safety features for urban use. Our 8.4 m. Sultan LF has brought new breath to the urban passenger transportation. We made public bus deliveries to Malatya and İnegöl as well as to leading companies such as Altur, Gürsel Tourism, Efateur, Sözkur and Tursan."

"We Are Carrying the World"

Basri Akgül went to say that Otokar's achievement in exports continued in 2017 despite the challenging two years experienced by the sector.

He said "Otokar brand vehicles continued to strengthen their position in Europe with their design, comfort, technology, power and low operating costs,"

"In 2017, we exported approximately 70 million euros in commercial vehicles. Last year, our overall car park in France, Italy and Spain, our export countries, reached 2.500 units. We exported articulated 18,75m. Kent for the first time, thus starting a new era with its peculiar features in urban public transportation. Our car park in the Balkans owns more than 500 units. We can say that as Otokar vehicles are transporting millions of passengers in more than 60 countries, we are carrying the world."



"Growth Achieved in Light Truck Market"

Deputy General Manager Basri Akgül, noting that they aim to maintain Otokar's success also in the logistics area in 2018, said that Atlas was also among Otokar's renewed vehicles in 2017 and it brought a new breath to the segment of light trucks.

He said, "Our Atlas sales increased above the market growth. With Atlas, we raised our market share by 3 points in 2017 and reached a share of 11%. We have made important deliveries of Atlas trucks throughout the year as found favourable thanks to the vehicle's load carrying capacity, powerful hardware features, low

running costs, environmental friendly and economical engine.

We offer solutions in transportation that requires expertise in trailer production.

We are assertive in 2018 with our pioneering tools in accordance with international standards and regulations, with technology for hazardous substance transport and perishable food transport sectors."

"Our Goal is to be Pioneer in Digital Transformation"

With R&D, engineering capability, experienced and competent human resources as from the time when Turkey started industrialization and modernization leap in up to now Otokar has achieved many firsts.

Akgül noted that Otokar is carrying out 15 separate projects for the 4th industrial revolution, called Industry4.0, adding;

"With digital transformation projects, our stakeholders - from production to suppliers and to agents - will have a new, smart business platform.

This platform will give us speed in our customer specific product development processes. Our goal is also to lead the digital transformation journey in the sectors we operate.

We will continue to invest in robotic control in the upcoming period, from document management to skill-based optimization."



"Among our first are the first hybrid bus and the first electric bus of Turkey.

We will continue to work on alternative fuel vehicles that will provide a cleaner environment, lower operating costs and higher efficiency in 2018."

Akgül said that Otokar's Smart Bus Project, developed in collaboration with KoçSistem and İSBAK, under CoMoSeF, became the "Celtic Innovation Award Winner 2017".

Aldığınız en anlamlı mesaj bu olabilir.

Bu gurur ve mutluluğu yaşamak için siz de
Türk Kızılayı'na gelip kan verin; hayat kurtarın.

**Unutmayın; bağışlanan her kan,
kurtarılan 3 can.**

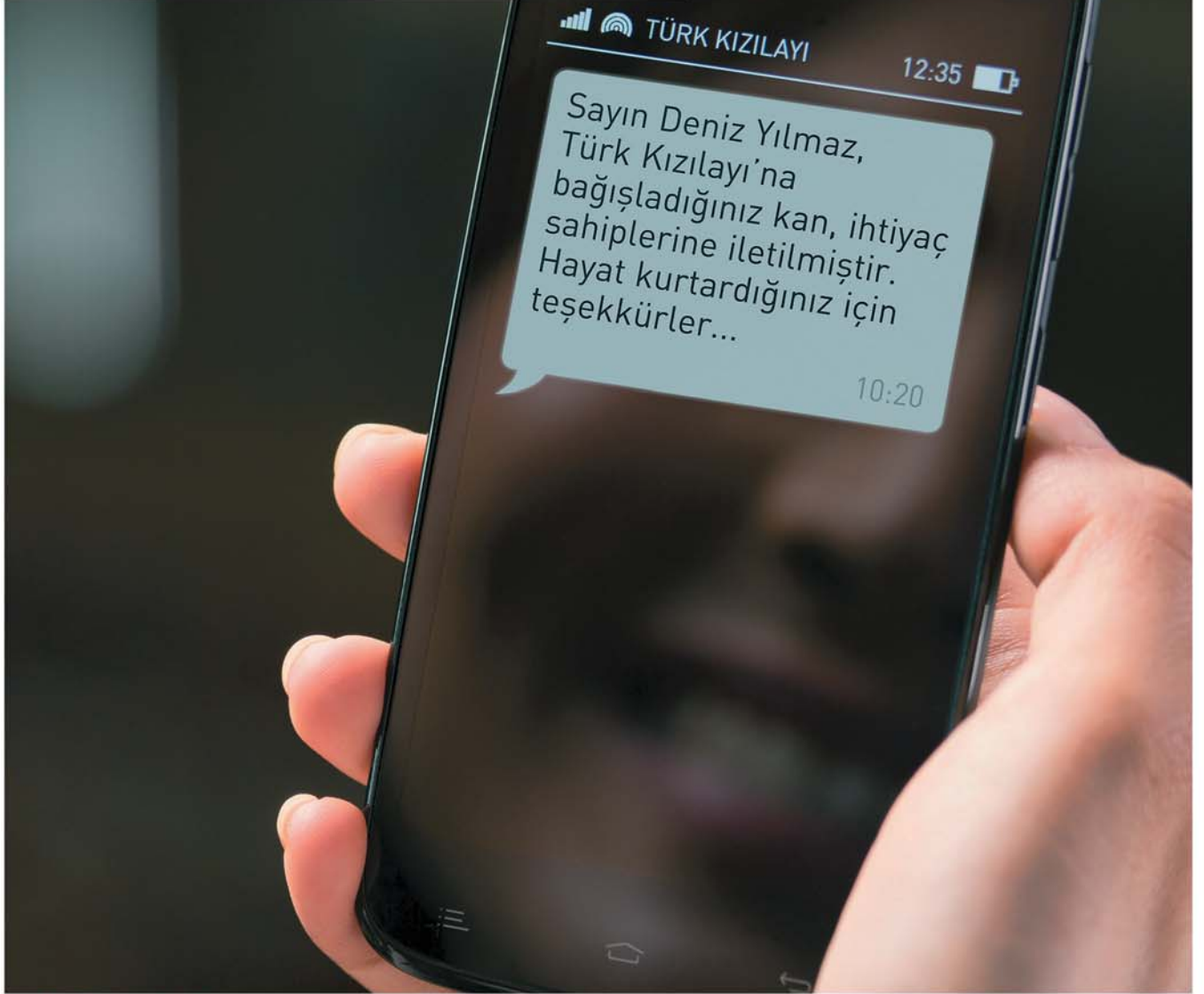

168
ÇAĞRI
MERKEZİ

KAN
BAĞIŞI
HAYAT
KURTARIR

#enanlamlimesaj

twitter.com/KanverOrg
facebook.com/Kanver.Org
youtube.com/kizilaykanver

Detay Haber Dergisi'nin katkılarıyla...

www.kanver.org



TÜRK KIZILAYI

1868

HAVING HAD FURTHER STRENGTH IN 2017, MAN WELCOMES 2018 WITH INNOVATIONS, ADVANTAGES AND AWARDS...

Having further developed its market share at the declining 2017 market, MAN will continue to make a difference with its unique concept in 2018, as well as new models with matchless advantages, a security concept through advanced technology and expertise in EURO 6.

At the Busworld Kortrijk Fair, also known as the European Coach Week (ECW), MAN stand became the center of attraction for the organization.

MAN's fully renewed Lion's Coach (2 axle 12 and 2 axle 13 m.), NEOPLAN's *Tourliner* (2 axle 13 m.) and Skyliner 50th year travel buses were exhibited at MAN's stand, which received great interest.



At Busworld Kortrijk 2017, New MAN *Lion's Coach*, which was displayed for the first time, received great acclaim, and having had three of the awards given in 6 categories in 2017, it attracted great attention. In addition to the Grand Coach Award, new MAN *Lion's Coach* was chosen as the best in the categories of Comfort Label and Design Label.

MAN reached 22% market share in the bus market last year. With its models that make up the higher class in their segments, mainly 2 -axle 13 m. new generation MAN *Lion's Coach* and again 2 -axle 13 m. version of NEOPLAN *Tourliner*, MAN will continue to appear with distinction in Turkey in 2018. By end of November 2017 MAN reached the sale of 129 ea vehicles and with its new models, it aims to raise both the sales and market share in the new year. In the narrowing 2017 market,

MAN managed to improve its market share upwards, and will continue to make a difference with its unique concept in 2018, as well as new models with matchless advantages, a security concept through advanced technology and expertise in EURO 6.

The leading brand of heavy commercial vehicles, *MAN Truck and Bus Co.* held its traditional meeting on 12 December to share the evaluations for 2017 and expectations from the new year.

The hosting managers were Director of Bus Sales Department **Can Cansu**, Director of Truck Sales Department **Serkan Sara**, Director of Second-Hand Sales Department **Aydın Yumrukçal** and Post Sale Services Director **Şinasi Ekinciöğlü**.

BUS

Having further raised its market share at the declining 2017 market, MAN will continue to make a difference with its unique concept in 2018, as well as new models with matchless advantages, and a security concept that has been created through advanced technology, and MAN's expertise in EURO 6.

At the Busworld Kortrijk Fair, known as the European Coach Week, MAN's stand dazzled the visitors with its fully renewed *Lion's Coach* (2 -axle 12 and 2 -axle 13 m.), NEOPLAN's *Tourliner* (2 -axle 13 m.) and Skyliner 50th year travel buses were exhibited at MAN's stand, arousing great interest.



New MAN *Lion's Coach* was displayed for the first time at Busworld Kortrijk 2017 and received great applause, and it marked the contest by gaining three of the awards given in 6 categories in 2017. In addition to the *Grand Coach Award*, new MAN *Lion's Coach* was chosen as the best in the categories of Comfort Label and Design Label. MAN reached 22% market share in the bus market last year. With its models that make up the higher class in their segments, mainly 2 -axle 13 m. new generation MAN *Lion's Coach* and again 2 -axle 13 m. version of NEOPLAN Tourliner, MAN will keep on being distinctive in Turkey in 2018, too.

By end of November 2017, MAN reached the sale of 129 ea vehicles and with its new models, it aims to increase both its sales and market share in the new year.



MAN raises share in travel bus market

Director of Bus Sales Department Can Cansu evaluated the year 2017 and shared his views on the new year forecasts. He pointed out that the year 2017 witnessed a serious shrinking compared to the previous year. Cansu said: "As MAN, we are able to get a share of 22% according to data by end of November. The sector is almost entirely turning to the 2+1 VIP bus. In order to meet the sector's expectations, we are launching our new products, 2 -axle 13 m. new MAN *Lion's Coach* 2+1 seat brands, which comprise 41-passenger capacity and 2+2 seat brands 55-passenger capacity."

Its even more confident new look exudes power and efficiency, and it is impossible to miss its technological enhancements. The optimised driveline and innovative assistance systems guarantee you enhanced engine performance, even though fuel consumption is reduced. With the addition of the new 13-m. version over two axles, MAN has extended its *Lion's Coach* portfolio to ensure that your fleet is optimised for use. *Lion's Coach* will continue to be the most demanding model with all these unique advantages offered by its renewed face.

The new Neoplan Tourliner will continue to be the most attractive model of the premium bus segment, with a new version of 2 axles 13 m. long.

Success going on at public sales

Public procurements which started fast in 2017, however slowed down in the second half. MAN's public sales unit sold 200 units in 2017 in direct deals. As in previous years, MAN continues to be the preferred choice for the segments in need of special-purpose and multi-featured vehicles.

When the distribution of sales are considered, it is seen that the main item consists of cranes, dumper and double pull tractors that will work under heavy conditions after the fire group.



TRUCK

MAN again comes first in Imported Truck Market

MAN, having improved its market share in the 2017 market, will continue to create difference with its unique concept in 2018, as well as new concept models with unequalled advantages, a security concept it has developed based on advanced technologies and its proficiency in EURO 6.

MAN, which is in a brand position that has elevated the market share in the Turkish truck market, has had its leadership certified in the area of customer satisfaction by means of surveys of independent research companies. By the end of October 2017, 12 -ton truck market witnessed a serious shrink..

Director of the Truck Sales Department Serkan Sara said that a narrowing by 6% was observed in the truck market by end of October as compared to the same period of previous year, adding that MAN Truck is the brand that maximizes its market the most share in terms of sales figures shared by TAİD in 2017.

Sara underlined, "MAN is making a difference in every field with its customer-oriented production approach.

The *EfficientLine* series developed with this approach shapes the sector with our superior features and additional solutions that we offer to our customers in our new series Euro 6C vehicles."

TURKISH CONTRACTORS' UNDERTAKINGS GAIN MAJORITY IN HOUSING SECTOR WORLDWIDE

According to the Economy Ministry, the Turkish contracting services undertook 9,258 projects worth \$ 354 bn648 mln in 119 countries as from 1972 until the end of 2017. The report says that Turkish contractors' undertakings abroad only last year reached 241 projects worth 14 bn666 mln dollars.

In the regional distribution of the works undertaken abroad from 1972 until the end of 2017, the Independent States Community and the Middle East countries came forward. In this period, Russia took the first place with a share of 19.4 % in the projects undertaken abroad. In this country, 68 bn788 mln dollar worth of business was undertaken. Turkmenistan followed with 13.2 % and a value of 46 bn844 mln dollars.

Tanzania goes ahead traditional markets for the first time

Turkish contracting firms undertook 190 projects in 56 countries, amounting nearly 13.6 bnUSD in 2016. With a total share of 42.8%, Qatar, Saudi Arabia, Russian Federation and Uzbekistan were the leading markets followed by Bahrain, UAE, Kuwait, Senegal, Pakistan, Ukraine. The total value of the projects completed in 2016 was quite low compared to the last three years. This situation was mainly explained by political and economic difficulties recently experienced in the North African, Middle Eastern and Eurasian countries which are the most important markets for the Turkish contractors. Especially unfavorable developments in Iraq and Libya, which have always been among the top markets for Turkish contracting, is thought to be the main reason for this decline.

Tanzania took the first order with a 17.3 % share and a project worth 2 bn531 mln dollars in foreign contracting works undertaken last year and followed by Saudi Arabia with a 14.1 % share and a 2 bn72 mln dollar project. Projects undertaken in Russia had a 12.1 % share with 1 bn771 mln dolar volume.. The projects for the United Arab Emirates were the fourth with a share of 9.1 % and a Project value worth 1 bn331 mln dollars. For the first time, a sub-Saharan African country has emerged as the most project-bearing country, ahead of traditional markets such as the Commonwealth of Independent States and the Middle East. The first place in the list of projects that Turkish contractors have undertaken so far is housing projects. In this sector, 46 bn865 mln dollars of undertaking was carried out.

Housing projects are followed by roads, tunnels and bridges with a volume of 45 bn743 mln dollars, and commercial center constructions with 29 bn396 mln dollars.

New target market Sub-Saharan Africa

According to the report of the Ministry, the number of countries whose projects have been undertaken in recent years has increased to 119 with the addition of Liberia, Chad, Rwanda, Sri Lanka, Czech Republic, Estonia, Madagascar, Malawi and Vietnam to traditional markets like the Middle East and the Commonwealth of Independent States. Ethiopia, Nigeria, Mozambique and Ghana have appeared to be the priority countries as a result of "target country" studies on the Sub-Saharan Africa under scope of the Ministry's activities.

2018 MINIMUM WAGE RAISED TO NET 1603 TL

The minimum wage was raised by 14 percent in 2018, for a monthly minimum wage of 1,603 liras (\$423.30), Minister of Labour and Social Security Jülide Sarieroğlu said. "We have made a 52 percent raise in the minimum wage on a cumulative basis over the last three years," said Sarieroğlu. The new gross minimum wage, before deductions such as social security premiums and income taxes, is 2,029 liras (\$534.6).

Minimum wage negotiations started in early

December with the participation of employer unions, worker unions and the government. The final wage was determined after a round of four sessions in total.

According to the newly determined minimum wage, a worker married with 3 children and whose wife is not employed will receive 1.709 TL. In a statement made by the Ministry of Labour and Social Security, the minimum wage will be valid from January 1, 2018 and it is determined as 2.029 TL gross and 1.603 TL net.

1998'den bugüne...
"Hayatımız Çocuklarımız"

20. YIL
LÖSEV
Lösemili Çocuklar Vakfı

Daha da Renkleniyor

turuncu

İYİLİĞİN

YARATICILIĞIN

sarı

yeşil

ÜRETMENİN

KARDEŞLİĞİN

turkuaz

mavi

GÜVENİN

KARARLILIĞIN

kırmızı

rengi...

20 yıl önce bir masa ve bir sandalye ile başladığımız bu yolculukta bizi yücelten gerçek kahramanlarımıza minnettarız



TURKEY'S 2017 CEMENT AND CLINKER FIGURES HAVE BEEN ANNOUNCED

■ Last year 80.5 million ton cement, 70.8 million ton clinker produced...

■ 7.9 million ton cement exports made during the 12-month period

The Private sector cement mills of Turkey are reported to have produced 80 mln 552. 257 ton cement by end of December 2017.

According to the data from the *Turkish Cement Suppliers Association*, Turkey's monthly cement production has been realized as 6.7 million ton on average. Of the total production, 7 mln 980.441 ton part was exported last year. ,The rest was consumed domestically. As is the case in previous years, Marmara factories produced (20 mln 566.157 ton) the most

cement and it is followed by the factories in the Mediterranean region with 18 mln 065.630 tons.

Meanwhile, Central Anatolian factories produced 13 mln 954.949 tons and Southeast Anatolia factories 6 mln and 104.692 tons and Aegean factories 6 mln and 37.811 tons..

By end of December 2017, the Factories in the Black Sea Region produced 9 mln 331.977 tons whereas those in the East Anatolia produced 6 mln 491.041 tons of cement.

CEMENT PRODUCTION, SALES, STOCKS BY REGIONS, DECEMBER 2017

	PRODUCTION		DOM.SALE		FORE.SALE		IMPORTED DOM. SALE		TOTAL SALES		STOCK
	MONTH.	ANNUAL	MONTH.	ANNUAL	MONTH.	ANNUAL	MONTH.	ANNU.	MONTH.	ANNUAL	
REGIONAL SUMS											
MARMARA	1.740.694	20.566.157	1.675.369	19.575.602	95.254	1.362.767	0	0	1.770.623	20.938.369	141.843
AEGEAN	602.312	6.037.811	550.347	5.419.847	65.007	625.592	0	0	615.354	6.045.439	85.715
MEDITERRAN.	1.594.581	18.065.630	1.044.165	12.172.100	452.098	5.198.819	0	0	1.496.263	17.370.919	223.639
BLACK SEA	726.692	9.331.977	709.915	9.032.760	17.234	289.204	0	0	727.149	9.321.964	95.727
C. ANATOLIA	1.082.973	13.954.949	1.082.181	13.936.852	0	3.000	0	0	1.082.181	13.939.852	173.711
E. ANATOLIA	354.324	6.491.041	354.582	6.398.922	1.233	83.054	0	0	355.815	6.481.976	54.228
S.E. ANATOLIA	484.400	6.104.692	453.184	5.691.177	28.116	418.005	0	0	481.300	6.109.182	45.457
NATIONAL TOTAL											
TOTAL	6.585.976	80.552.257	5.869.743	72.227.260	658.942	7.980.441	0	0	6.528.685	80.207.701	820.320

CLINKER PRODUCTION, SALES, STOCKS BY REGIONS, DECEMBER 2017

	PRODUCTION		PURCHASED		DOM.SALE		IMPORTED		FOREIGN SALE		STOCK
	MONTH.	ANNUAL	MONTH.	ANNUA.	MONTH	ANNU.	MONTH.	ANNU.	MONTH.	ANNUAL	
REGIONAL SUMS											
MARMARA	1.570.241	18.201.924	111.516	1.015.022	37.019	577.390	0	53.250	40.000	870.950	437.280
AEGEAN	464.331	4.752.600	6.882	250.494	7.805	284.804	0	0	0	604.352	67.042

MEDITERRAN.	1.698.246	17.766.681	4.495	201.405	2.999	213.076	0	0	236.621	3.139.719	894.281
BLACK SEA	620.663	7.082.317	35.336	530.816	56.717	710.254	0	0	0	0	345.613
C. ANATOLIA	1.119.868	12.852.885	588	105.290	77.367	541.525	0	0	0	0	547.817
E. ANATOLIA	453.504	4.928.821	23.506	287.669	21.442	341.505	0	0	0	73.052	537.245
S.E. ANATOLIA	511.523	5.227.331	0	0	4.188	93.241	0	0	33.410	244.145	321.839
NATIONAL TOTAL											
TOTAL	6.438.376	70.812.559	182.323	2.390.696	207.537	2.761.795	0	53.250	310.031	4.932.218	3.151.117

CEMENT PRODUCTION, SALES, STOCKS BY REGIONS, DECEMBER 2016

	PRODUCTION		DOM.SALE		FORE.SALE		IMPORTED DOM. SALE		TOTAL SALES		STOCKS
	MONTH	ANNUAL	MONTH	ANNUAL	MONTH	ANNUAL	MONT	ANNU.	MONTH	ANNUAL	
REGIONAL SUMS											
MARMARA	1.335.952	19.177.817	1.292.422	17.798.865	59.406	1.436.476	0	0	1.351.828	19.235.341	194.866
AEGEAN	471.731	6.078.776	430.684	5.317.293	0	523.977	0	0	430.684	5.841.270	82.802
MEDITERRAN.	1.060.583	18.159.749	718.120	12.583.743	304.303	4.841.899	0	0	1.022.423	17.425.642	262.271
BLACK SEA	428.571	9.051.464	419.891	8.672.754	12.422	294.915	0	0	432.313	8.967.669	103.323
C. ANATOLIA	542.031	12.123.726	528.611	12.096.096	0	0	0	0	528.611	12.096.096	150.602
E. ANATOLIA	116.291	5.564.619	112.990	5.402.992	4.722	41.881	0	0	117.712	5.444.873	58.415
S.E. ANATOLIA	261.717	5.247.174	237.373	4.932.860	27.270	321.975	0	0	264.643	5.254.835	47.325
NATIONAL TOTAL											
TOTAL	4.216.876	75.403.325	3.740.091	66.804.603	408.123	7.461.123	0	0	4.148.214	74.265.726	899.604

CLINKER PRODUCTION, SALES, STOCKS BY REGIONS, DECEMBER 2016

	PRODUCTION		PURCHASED		DOM.SALE		IMPORTED		FOREIGN SALE		STOCKS
	MONTH	ANNUAL	MONTH	ANNUA	MONTH	ANNUA	MONT	ANNU.	MONTH	ANNUAL	
REGIONAL SUMS											
MARMARA	1.279.665	17.616.875	43.153	599.809	87.125	581.253	24.000	101.044	87.925	1.178.452	706.176
AEGEAN	330.553	4.551.869	40.979	50.847	17.047	17.047	0	0	34.858	330.682	308.348
MEDITERRAN.	1.365.016	18.226.004	0	80.055	1.969	214.337	0	0	49.730	2.108.762	1.976.607
BLACK SEA	647.738	7.474.811	47.036	518.414	49.941	664.217	0	0	0	0	576.406
C. ANATOLIA	921.667	10.898.943	15.720	365.756	30.398	442.961	0	0	0	0	704.655
E. ANATOLIA	344.071	4.641.886	14.471	277.067	2.340	79.680	0	0	0	4.359	827.535
S.E. ANATOLIA	494.504	4.445.846	0	28.565	8	33.639	0	0	12.837	102.703	562.184
NATIONAL TOTAL											
TOTAL	5.383.214	67.856.234	161.359	1.920.513	188.828	2.033.134	24.000	101.044	185.350	3.724.958	5.661.911

EMLAK KONUT GYO'S SALES REACH A TURNOVER OF 7.7 BILLION TL IN HOUSING LAST YEAR

Closing the year 2017 with a sales turnover worth 7.7 billion TL, Emlak Konut GYO aims to maintain its success in 2018.

Emlak Konut GYO announced that the company realized a sales volume of 7.7 billion TL (VAT excluded) in housing sector, with the size of 1.1 million square meters between January 1, 2017 and December 31, 2017.

2017 targets kept up to a great extent

Emlak Konut GYO General Manager Murat Kurum, evaluating the figures of 2017, said that they considered the 2017 as a period of recovery and revival after a difficult process and turmoils which experienced in the country in 2016.

Kurum said: "We said early 2017 to be hand in hand for a powerful Turkey and with the help of financial institutions we also reached record sales figures in a very short time. In the rest of the year, we provided opportunities such as different payment options or debt closures in our projects in order to support the positive momentum of the sector. When we look at the present, we see that we achieved our targets at the beginning of 2017 to a great extent.

In 2017, we reached sales of facilities in size of 1.1 million square meters, at a value of 7.7 billion TL. We also target to obtain a net profit of 1.8 billion TL in 2017."

With 9 revenue share tenders, a value worth 13 bln TL in 2017

General Manager Kurum evaluated the other activities of Emlak Konut during the year, together with the performance of the sector, adding that the real estate sector and the country's economy, which together make up the whole, showed how resistant they are to the external factors in 2017.

"When we examine the TÜİK data, we can see that the first and second hand sales of housing realized in total in 2017 were above the figures of previous year. The 3rd quarterly growth figures indicate that our economy had a growth rate of 11.1%.

This ratio is also the highest among the 3rd quarter values announced in all the countries of the world.

Again in 2017, the dream of the domestic automobile turned into a concrete project. Export figures reached the satisfactory levels and the 2nd highest export level has been reached of the history of the Republic.

We can say these figures very easily, but we can see that it is really a great administrative success. In our capacity to support this endeavor of our state, we also carried out many activities during the year apart from the housing sales.

When we look at our activities in the year 2017, we realized the purchase of land worth 1.27 billion TL. Our company completed various large-scale projects in 2017.

The projected sales rate in 2017 indicate that the rate reached 95%. In 2018, the sales rate in our projects planned for delivery has already reached 74%."

Emlak Konut to obtain a profit of 1.8 bln TL through its sales worth 7,2 bln TL in 2018

General Manager Kurum, who made a sector evaluation for 2018 and explained the company targets, pointed out that they want to continue this success that has been caught after a successful year.

Kurum said, "Our industry is one of the most important wheels of the country's economy. The Real estate sector that contributes to many subsidiary sectors also provides serious support to employment. We believe that our sector will, in a locomotive position, keep on its investments in the new year.

We plan to open tender for our plots out of our outstanding portfolio with a total of TL 5.3 billion worth of land, which attracts attention with the central locations such as Küçükçekmece, Şişli, Bakırköy, Florya, Çekmeköy and Bahçekent in Istanbul.

We will also carry out auctions in Ankara Saraçoğlu and Samsun. We plan to create a business volume of 10 billion TL with the land values of about 2.1 billion TL.

We are planning to launch our projects in 2018, which we realized in 2017 after their permit transactions. We have a sales target of TL 7.2 billion for this segment in 2018. In addition, we aim to sell 830 thousand m2 of independent sections and obtain a net profit of TL 1.8 billion in total this year "

TURKISH AUTOMOTIVE INDUSTRY FIGURES FOR JANUARY-DECEMBER 2017 ISSUED

Turkey's overall automotive production rose by 13% amounting to 1-mln 674.000 units and automobile production by 18% amounting to 1 mln 121.000 units in 2017 as compared to 2016,...

The *Automotive Manufacturers Association (OSD)* has issued its 2017 automotive sector figures.

Turkey's total automotive and automobile production is reported to have increased 13 percent to 1.7 million and 18 percent to 1.1 million, respectively, an all-time high for the industry in 2017

In Turkey last year, the total automotive production increased by 13 percent to 1.7 million compared to 2016, while automobile production reached 1.1 million with an increase of 18 percent, providing the sector with the highest levels in both total automotive and automobile production.

The Automotive Manufacturers Association (OSD) announced its annual production results covering the January-December 2017 period.

With these figures, both total automotive and automobile production reached their highest levels in Turkey. Including tractors, total production reached 1.7 million units last year.

Last year, production rose by 3 percent in the commercial vehicle group, 2 percent in the light commercial vehicle group and 23 percent in the heavy commercial vehicle group.

While this change in heavy commercial vehicles was driven by a base effect, production decreased by 32 percent.

80% of Production Exported

In 2017, total automotive exports increased by 17 percent and automobile exports by 24 percent compared to the previous year. In this period, total exports amounted to 1.3 million units, followed by automobile exports with 921,000 units. Thus, 80 percent of the total production in the automotive industry was exported.

In the same period, total automotive exports increased by 20 percent to \$29 billion, which corresponded to 25.7 billion euros with an increase of 17 percent.

Automobile exports, on the other hand, increased by 41 percent to \$11.8 billion, which amounted to 10.5 billion euros with an increase of 39 percent. Tractor exports also decreased by 4 percent compared to 2016, reaching 13,123 units.

In this period, main industrial exports increased by 25 percent and subindustry exports by 10 percent in dollar terms.

According to the Turkish Exporters Assembly (TİM) data, total automotive industry exports maintained the leading position in 2017 with an 18.2 percent share in exports.

Rise in Domestic Production Sales in Local Market

In 2017, the total market decreased by 3 percent to 980,277 units. In this period, the automobile market narrowed by 5 percent to 722,759 units.

Last year, the commercial vehicle market and light commercial vehicle market grew by 3 percent compared to the previous year, while the market maintained the same level in the heavy commercial vehicle group.

The market contraction in the heavy commercial vehicle group reached 44 percent in the last two years.

The market share of imports in automobile sales was 70 percent in 2017.

In 2017, total automobile sales decreased by 5 percent and imported automobile sales by 10 percent compared to the previous year, while domestic automobile sales rose by 13 percent.

The recently introduced automobile projects had a significant effect on the increase in the share of domestic production in the automobile market.

The market share of imports in light commercial vehicle sales, on the other hand, stood at 47 percent. Last year, total light commercial vehicle sales increased by 3 percent, domestic light commercial vehicle sales by 4 percent, and light commercial vehicle sales by 2 percent compared to 2016.

In 2017, the heavy commercial vehicle market maintained the same level compared to the previous year, reaching 24,083 units. In the same period, the truck market increased by 1 percent to 21,067 units, and the minibus market by 5 percent to 2,120 units, while the bus market decreased by 34 percent to 896 units.

**AUTOMOTIVE PRODUCTION, SALES, EXPORTS & IMPORTS FIGURES FOR 2017
AUTOMOTIVE INDUSTRY FIRMS' DECEMBER 2017 PRODUCTIONS**

FIRMS	PASS. CAR	%	L. TRUC.	%	MD. TRUCK.	%	PICK UP	%	BUS	%	MINIBUS	%	MİDİBUS	%	TRACTOR	%	TOTAL
A.I.O.S.			300	62			289	1	18	3			73	16			680
FORD OTOSAN	2.042	3			778	35	29.890	61			4506	97					37.216
HATTAT TARIM															595	13	595
HONDA TÜRKİYE	3.106	4															3.106
HYUNDAI ASSAN	17.740	24															17.740
KARSAN							462	1	40	7	163	3	46	10			711
MERCEDES BENZ TÜRK					1.440	65			280	50							1720
MAN TÜRKİYE									179	32							179
OTOKAR			63	13			24	0	40	7			206	44			333
OYAK RENAULT	10.886	15															10.886
TEMSA GLOBAL			120	25									138	30			258
TOFAŞ	14.245	20					18.031	37									32.276
TOYOTA	24.974	34															24.974
TÜRK TRAKTÖR															4.050	87	4.050
TOTAL	72.993	100	483	100	2.218	100	48.696	100	557	100	4.669	100	483	100	4.645	100	134.724

AUTOMOTIVE INDUSTRY FIRMS' 12-MONTH PRODUCTIONS IN 2017

FIRMS	PASS. CAR	%	L. TRUC.	%	MD. TRUCK.	%	PICK UP	%	BUS	%	MINIBUS	%	MİDİBUS	%	TRACTOR	%	TOTAL
A.I.O.S.			2.534	62	35	0	2.542	1	353	4			902	24			6.366
FORD OTOSAN	25.844	2			6.000	31	287.355	62			53.806	98					373.005
HATTAT															5.539	10	5.539
HONDA TÜRKİYE	28.742	3															28.742
HYUNDAI ASSAN	226.979	20															226.979

KARSAN						4.290	1	180	2	1.230	2	327	9		6.027		
MERCEDES BENZ TÜRK				13.351	69			3.792	46						17.143		
MAN TÜRKİYE								2.145	26						2.145		
OTOKAR			430	10				465	0	493	6		1.319	35	2.707		
OYAK RENAULT	342.935	31													342.935		
TEMSA GLOBAL			1.152	28				1.203	15			1.184	32		3.539		
TOFAŞ	216.437	19						167.737	36						384.902		
TOYOTA	279.902	25													279.902		
TÜRK TRAKTÖR													48.302	90	48.302		
TOTAL	1120.839	100	4.116	100	19.386	100	462.389	100	8.166	100	55.036	100	3.732	100	53.841	100	1.727.505

A COMPARISON OF AUTOMOTIVE INDUSTRY'S PRODUCTIONS : 2016 vs. 2017

	December Production		12 –month Production		Change (%)	
	2016	2017	2016	2017	DECEM.	12 months
Pass.Car	106.963	72.993	950.888	1.120.839	-32	18
TOTAL	106.693	72.993	950.888	1.120.839	-32	18
Md. truck	903	2.218	14.826	19.386	146	31
L. truck	276	483	2.548	4.116	75	62
Pick-up	43.003	48.696	461.837	462.389	13	0
Bus	495	557	8.083	8.166	13	1
Minibus	4.239	4.669	44.415	55.036	10	24
Midibus	236	463	3.330	3.732	96	12
Commer.vehicles total	49.152	57.086	535.039	552.825	16	3
Transp.vehicles total	156.115	130.079	1.485.927	1.673.664	-17	13
Tractor	3.480	4.645	50.746	53.841	33	6
GRAND TOTAL	159.595	134.724	1.536.673	1.727.505	-16	12

AUTOMOTIVE INDUSTRY CAPACITY USAGE /2017

	December Production		12 –month Production		Change (%)	
	Capacity	Production	Capacity	Production	DECEM.	12 months
Light Vehicles	153.883	126.358	1.846.596	1.638.264	82	89
Truck	4.000	2.701	48.000	23.502	68	49
Bus	1.083	557	12.996	8.166	51	63
Midibus	820	463	9.840	3.732	56	38
Tractor	6.250	4.645	75.000	53.841	74	72
TOTAL	166.036	134.724	1.992.432	1.727.505	81	87

AUTOMOTIVE INDUSTRY FIRMS' PRODUCTION CAPACITIES IN 2017

FIRMS	AUTOMOBILE	TRUCK	PICKUP	BUS	MINİBUS	MİDİBUS	TRACTOR	TOTAL
A.ISUZU	0	8.000	7.300	1.070	2.642	0	0	19.012
FORD OTOSAN	30.000	15.000	334.000	0	36.000	0	0	415.000
HATTAT	0	0	0	0	0	0	25.000	25.000
HONDA TÜRKİYE	50.000	0	0	0	0	0	0	50.000
HYUNDAI ASSAN	245.000	0	0	0	0	0	0	245.000
KARSAN	0	0	40.500	2.025	7.000	2.700	0	52.225
MAN TÜRKİYE	0	0	0	2.400	0	0	0	2.400
MERCEDES BENZ TÜRK	0	17.500	0	4.500	0	0	0	22.000
OTOKAR	0	0	5.300	1.000	1.500	2.500	0	10.300
OYAK RENAULT	360.000	0	0	0	0	0	0	360.000
TEMSA GLOBAL	0	7.500	0	2.000	0	2.000	0	11.500
TOFAŞ	450.000	0	0	0	0	0	0	450.000
TOYOTA	280.000	0	0	0	0	0	0	280.000
TÜRK TRAKTÖR	0	0	0	0	0	0	50.000	50.000
TOTAL	1.415.000	48.000	387.100	12.995	47.142	7.200	75.000	1.992.437

BANKING SECTOR'S FORECASTS IN 2018

In the banking sector, the fastest growth in recent years has been recorded with credits backed by KGF (Credit Guarantee Fund). While the KGF effect in 2018 is not expected to be so high, it is still expected to grow by around 15 percent.

The banking sector, which has achieved the best credit growth in recent years with the credits supported by the Credit Guarantee Fund, is not anticipated to grow at the same pace in 2018, high deposit costs and declining mortgage loans will be high on the agenda.

While the credit growth expected in the Turkish banking sector at around 22 percent with the momentum created by credits supported by the KGF in 2017 shows the highest performance in recent years, it is expected that this will be reflected positively in the profit of the sector. According to the BDDK data, the sector loans reached 2.05 trillion TL at the end of October and net profit 41.2 billion TL in Jan.-Oct. period with an increase of 28.3 percent.

13-15% Credit Growth Foreseen

By the end of November, about 221 billion TL worth of loan volume was made available under the KGF, and it is envisaged that the credit growth will take place in the range of 13-15 percent, although not so much as in 2017, with the continuing implementation of the KGF this year.

"The marginal impact of the KGF will not be the same this year," said Sadrettin Bağcı, Deniz Yatırım Banking Analyst.

He added, "The limit was 250 billion TL and most of it was disbursed, and probably the realization will be as much as half of this amount."

Expressing that the interest rates of deposits increased a little more in the last quarter, after an increase because of the effects of KGF, Bağcı noted that they predict to see them to be at high levels in the first quarter. He said, "While the rise in deposit rates, which is at the level of 13 percent nowadays, kept its place on the agenda throughout 2017, the economic administration called for banks to cut interest rates at every opportunity. Housing sales have been reduced in recent months and that the demand is below the supply. And another issue high on the agenda in 2018 will be the weakness in the demand for housing loans."

"Demand for mortgage loans is also weak. The demand for housing loans may weaken because housing prices are not rising, which may slow down

lending to the construction sector. Secondly, it may also be seen as an active asset, perhaps just like a KGF for home loans, or it may be incentives to vitalize the housing sector", Bağcı said.

The Housing Developers and Investors Association (Konutder) Chairman Altan Elmas said that at least 10 percent of the sector's losses has been experienced since the beginning of the year due to the reluctance of banks to extend housing loans and that housing sales were being further suppressed with the rise witnessed in loan rates in the last quarter.

"Deposit costs and swap balancing the most important topics"

Global Securities Banking Analyst Kerem Mimaroglu said that the growth rate of the banking sector could be around 15-16 per cent in 2017, which is expected to be around 22 per cent this year. There may be a similar picture in deposits, too. He noted that the costs of deposits and swap balances are the most important topics to be monitored

Over 200,000 companies benefited from KGF scheme

In March last year, Turkey raised the volume of the KGF by more than ten-fold to 250 billion liras in line with measures to boost the economy. Turkish businesses showed a great interest to this type of financial support, adding that a total of 202,000 companies had used 197 billion liras (\$50 bln) of loans under this scheme so far.

The Credit Guarantee Fund was established to support small and medium-sized enterprises and to provide collateral to enable them to use bank loans in financing their investments and operations.

Meanwhile, the Turkish banking sector posted a 4.5 billion TL (\$1.2 billion) net profit in January 2018, according to the Banking Regulation and Supervision Agency (BDDK). In January, the net profit of the sector recorded a 22.7 percent rise year-on-year, compared to 3.7 billion TL (\$974 mln) net profit in the same month of last year. Last year, Turkish banking sector's net profit hit its all-time high, reaching 49.1 billion TL (\$13 bln) with a yearly increase of 30.8 percent.

Loans given by banks — the biggest sub-category of assets — stood at 2.1 trillion Turkish liras (\$564.8 billion) at the end of January marking a 17 percent yearly increase. Deposits held at the country's banks amounted to 1.7 trillion Turkish liras as of January, indicating a 14.3 percent rise on a yearly basis.

EXPORTS IN TURKISH LIRA RISE FIVE FOLD IN 7 YEARS

The share of TL in total exports, which was 2.3 percent in 2010, became 9.2 percent in 11 months last year ...

The share of TL in foreign trade with the countries that Turkey have agreed in recent years is gradually increasing.

By the end of November 2017, the share of TL in total exports between 2010 and 2017 increased 5 times compared to 2010 and reached 13 billion 173 million dollars.

In the same period, TL-denominated imports have nearly tripled to 16 billion 463 million dollars. The euro, the most widely used currency type, has risen above dollar in exports since 2016. During the 11-month period of 2017, the share of euro in exports increased to 47.7%.

As Trading with local currency reduces countries' foreign exchange requirements, especially in foreign currency-dependent countries, currencies provide a significant advantage at the point of preventing speculative movements.

This situation also allows the exporters to see ahead, while at the same time preventing the increase in the current account deficit, which is one of the important elements of the economy.

Turkey, being seriously determined in this regard in recent years, began to take the fruits of the efforts exerted. At meetings with the leaders of countries that do not have dollars or euros, President Recep Tayyip Erdoğan brings to the agenda the rise of the amount of trade that countries mutually make through their own currencies

Especially at meetings with Russia and Iran, trade with local currencies was added to the reconciliation texts. Trade with local currencies finally came to an end at the D-8 summit in Istanbul in October 2017. Speaking at the summit, Erdoğan said the \$100 -billion trade volume between the member countries should be raised to \$ 500 billion

At this meeting, it was agreed that local currencies should be used in trade among the D8 countries. Through Turkey's initiatives the D8 was established in 1997 with Iran, Pakistan, Bangladesh, Malaysia, Indonesia, Egypt and Nigeria as well as Turkey.

According to the compilation from TÜİK data, 2 billion 640 million TL part of the exports, which reached 113.8 billion dollars in 2010, was realized in TL and the share of TL in exports was 2.3 percent.

In 2011, 2.54 percent of the 134.2 billion dollar worth of exports, corresponding to 3 billion 433 million dollars, was realized with TL.

In 2012, the 4 billion 490 million dolar portion of 152.4 billion dollar exports was in TL, which accounted for 2.94 percent share in the overall exports.

In 2013, the share of the trade in TL within the 151.8 billion dollar total exports rose to 3.52 percent.

In 2014, 4.24 percent of the 157.6 billion dolar exports was made in TL (6 billion 695 million dollars)

While in 2015, the share of TL in the 143.8 billion dolar exports increased to 4.25 percent (6 billion 90 million dollars).

In 2016, the share of TL became 7 bln 877 mln dollars, which meant 5.52 percent, within the overall 142.5 bln dollars. During the 11 month period of 2017, the 13 bln 173 mln dolar portion of the 143.2 bln dolar exports was realized in TL, which corresponds to 9.19 percent .

The share in imports 8 percent

The share of TL in imports is also increasing. While 3.1 percent of the imports worth 185.5 billion dollars in 2010 were made in TL, 3.1 percent of the imports worth 240.8 billion dollars in 2011 was realized in TL. The share of TL in imports reached 4 percent in 2012, 4.5 percent in 2013, 5.1 percent in 2014, 6.5 percent in 2015 and 7.2 percent in 2016.

During the 11 month period of 2017, 7.8 percent of the imports worth 210 bln 703 mln dollars was carried out (16 bln 463 mln dollars).

Dollar, which had been in the first place in Turkey's exports since 2013, was replaced by euro after this time.

The share of euro in exports in 2010 was 48.2 percent, 47.7 percent in 2011 and 47.6 percent in 2012 The share in 2013 reached 45.6 percent.

In exports, the euro received a 44.4 percent share in 2014 and 44.6 percent in 2015.

The share of the dollar was 45.4 percent in 2010, 46 percent in 2011 and 2012, and 47.4 percent in 2013 and 2014.

In 2016, the euro once again moved forward. In 2016, the share of euro in exports was 48.2 percent, while the share of dollar was 42.6 percent. In January-November 2017, euro received 47.7 percent and dollar 39.4 percent.

In imports, the dollar has a clear superiority.

PUBLIC ALLOCATION 8.5 BLN TL TO TWO SECTORS

The total amount of investment allocated to the energy and mining sectors by the public has reached 8 billion 512 million liras, an increase of about 25 percent compared to the previous year. According to the 2018 Investment Program, of the investments to be realized this year, 5.706.217.000 TL has been allocated to 155 projects in the energy sector and 2.805.790.000 TL to 58 in the mining sector.

The Turkish Electricity Transmission Co. (TEİAŞ) has the largest share of the energy investment.

A total of 2.850.000.000 TL investment budget has been allocated for its projects which are going on and will start this year.

DSİ Comes Second in Distribution of Financing

TEİAŞ will carry out a total of 97 projects. It is followed by the State Hydraulic Works (DSİ) with 12 projects. DSİ has received a financial source of 1.603.000.000 TL.

The Electricity Generation Co. (EÜAŞ) comes 3rd with its share in energy investments.

EÜAŞ has received 1 billion TL for 15 projects.

Majority of Financing to TPAO in Mining

In the Mining sector the highest share of financial source has been obtained by the Turkish Petroleum Corporation (TPAO).

For its ongoing and new projects, a total of 1.599.616.000 TL investment budget has been allocated in 2018. TPAO will carry out a total of 13 projects. For its new projects a total financing of 1.168.313.000 TL has been reserved.

The second largest share of public investments in mining has been obtained by the Mineral Research and Exploration General Directorate (MTA).

For 7 projects, a total of 450.706.000 TL has been allocated to MTA. EÜAŞ comes third with the share of public investments in mining. For 11 projects it will receive 240.380.000 TL.

In the last year's investment program, the energy and mining sectors had received a total financing of 6.799.067.000 TL.

GOVERNMENT'S SPECIAL INCENTIVE MECHANISM TO BE PUT INTO FORCE

The Economy Ministry has disclosed the *Input Supply Strategy (GİTES) Action Plan* prepared for the 2017-2019 period with the objective of promotion of investment in inputs that are highly imported by Turkey, and production of export-oriented high-technology products. The government is set to announce a number of projects totaling almost TL 80 billion (\$21.2 billion), Economy Minister Nihat Zeybekci said. He confirmed that the projects, which are part of the government's Project-Based Support System or "super incentives" would be made public in the ensuing period. Zeybekci announced that the ministry prepared the decisions of the Council of Ministers under the program of Centers of Attraction and that some of the investment incentives in 23 provinces will be evaluated within this scope of the sixth region incentives. The projects are chosen from seven sectors in which Turkey is highly dependent on imports. "We needed to have a project-based incentive system to create our own 'giants' in sectors where we are in need of technology transfer and show a current account deficit," he said. The investment incentives will

include exemption from income and corporate tax for 10 years as well as government support on employee insurance premiums and financing interest rates.

The Minister said, "We determined seven sectors. Turkey shows a current account deficit in transportation, health, communication, energy, metallurgy, petrochemistry and the agricultural technology sectors. Turkey is also short of technology in these sectors."

Priority to R&D for Driver Assistant Systems

R&D activities will be primarily supported by joint research with TÜBİTAK for the production of inputs with high imports. Within this scope, R&D priority products include alternative inputs such as biopharmaceuticals, advanced material technologies, sensor technologies for the automotive subsidiary, drive assistant systems. The existing research infrastructure in the fields of electronic and embedded software with priority designation will be strengthened. Project invitations will be announced in the areas of vehicle dynamics and control, smart transport systems, automotive sensors and algorithms.

2018 WILL BE YEAR OF TAX REFORMS

The Ministry of Finance aims to legislate four separate legislative acts as tax reforms after submitting to the Turkish Grand National Assembly in 2018. With the amendment to be made with four separate laws in 2018, it is expected that a step will be taken on tax reform, as has been on the agenda for a long time.

The Draft Laws on Income Tax, Tax Procedures, Value Added and Istanbul Finance Center constitute the piers of the tax reforms mentioned frequently by Finance Minister Naci Ağbal during the budget debates.

A simple, more competitive and growth-friendly tax system is envisaged with the legal regulations planned to be put into effect by the economy administration in 2018.

Two tax laws to be combined

First, the Law on Income and Corporation Tax will be merged. The Ministry of Finance, aiming to refine the Income Tax Law, which has been in effect since 1961, under a comprehensive reform, is continuing studies on this draft. The Ministry, which received views from non-governmental organizations, also examined the implementations in other countries.

The Income Tax law draft studies have been completed on a large scale, and a taxpayer-focused taxation system has been targeted to expand the tax base, facilitate tax compliance, improve predictability, increase investment and value-added production.

VAT to drop in investments

Another regulation to be reformed is the Value Added Tax Law.

The economy's management, which explains that the Value Added Tax Law will reduce the tax compliance costs, encourage domestic production and investment, through an approach that removes the burden of VAT on investment, production and export, is planning an arrangement that will reduce the costs of SME's compliance with the tax, decrease the burden of additional financing due to the VAT on investments.

Examining the VAT system in the United Kingdom, compiling the suggestions from the relevant sectors, the Ministry of Finance aims to apply the UK's flat-rate tax system to SMEs Turkey.

The Finance Ministry's 2018 agenda also includes the Draft Law on Tax Procedures and the Istanbul International Finance Center Draft Law.

The new Tax Procedure Code will be designed to resolve the disputes in a short time and to provide a deterrent structure to raise the voluntary compliance in the tax penalties.

With The Istanbul International Finance Center Draft Law, arrangements will be made for the improvement of the necessary legal, physical, human and tax infrastructure to ensure the development of the financial system in Turkey in order to transform Istanbul into a regional and global financial hub.

ARRANGEMENT ON KGF LOANS

A new Treasury-backed credit tranche was put into by the Turkish Government in the Official Gazette dated 1 January 2018, in an effort mainly to spur growth in manufacturing and export sectors.

The related protocol for the use of a 55 billion lira scheme, including 5 bln in returns, was signed by officials from the Credit Guarantee Fund (KGF) and the Treasury. Turkish companies have already borrowed around 200 billion liras under the plan, but the remaining part of the scheme was not open to use until now. Deputy Prime Minister Mehmet Şimşek said almost half of this amount, 25 billion liras, of credits would be used by the manufacturing sector and some 15 billion liras by Turkey's exporters. Şimşek said the credit scheme was an effective policy tool.

"Some 50 billion liras of this amount are composed of new warrants and the remaining 5 billion lira is of returns," he added. Saying that the new scheme would be used to realize Turkey's main macroeconomic priorities, Şimşek added: "In an effort to put the current account deficit at sustainable and manageable levels, we have prioritized some investments. In this vein, some 25 billion liras of credits will be used by the manufacturing sector and 15 billion liras by the export sector. Thus, we will allocate almost two-thirds of the new credit scheme to spur Turkey's production power."

Şimşek said that Turkish businesses showed a great interest to this type of financial support, adding that a total of 202,000 companies had used 197 billion liras (\$50 billion) of loans under this scheme so far.

DEVELOPMENTS IN AGRICULTURE IN 2017

Some of the developments in the Turkish agricultural sector in 2017 are summarized in the following chapters:

1- According to the Turkey Statistical Institute (TÜİK), Turkey's economy grew by 7.4 percent, agriculture grew 3.3 percent in the same period in the first 9 months of 2017. The difference is much bigger in the third quarter of the year. Growth in economy in the third quarter was a record 11.1%, while growth in agriculture was only 2.8%.

2- The agricultural subsidy budget was determined at 12.8 billion TL for the year 2017. Agricultural subsidies were published in the Official Gazette dated August 18, 2017 and entered into force.

3- The National Agriculture Policy was put into practice as of 1 January 2017. The Basin-based Subsidy Model for crop production supported 21 products identified in 941 basins. Subsidy payments have been paid in two installments.

4- In 2017, defined as "golden year" in agricultural imports, in the framework of the food price reduction and inflation program, customs taxes were reduced or zeroed in cereals, pulses, feedstuffs, livestock and red meat trading.

5- The Meat and Milk Institute was authorized to make imports in Livestock and red meat business, and the State Grain Board (DMO) in cereal products with zero import duty.

6- While the harvest was beginning in agriculture, a Cabinet Decision was published in the Official Gazette dated June 27, 2017, stipulating customs duty reductions as follows: from 130 to 45 per cent for wheat imports, to 35 per cent for barley, to 25 per cent for corn. Meanwhile, the same decision stipulates customs duties to be reduced from 135 to 26 percent for livestock (cattle) imports and from between 100 to 225 percent to 40 percent for Carcass meat.

7- According to the decisions of the Council of Ministers published in the Official Gazette dated 22 November 2017, the rates of customs duties were rearranged with products including animal feeds, oilseeds, medicinal plants, forage and coarse fodder.

8- With the decision of the Council of Ministers published in the Official Gazette dated December 2, 2017, the customs duty was also nullified in the import of chickpeas, dried beans, shell beans and cowpeas species. The application will last until 1 June 2018.

9- Within the scope of the amendment made in the Council of Ministers, Food, Agriculture and Livestock Minister Faruk Çelik transferred his duty to Ahmet Eşref Fakıbaba in July.

New Minister Fakıbaba changed both the position and the politics and focused on red meat in the directives of President Recep Tayyip Erdoğan to sell cheaper meat to people.

10- Ziraat Bank was transferred to the Asset Fund. The bank had been meeting 60 per cent of the loans granted in the agricultural sector alone, with agricultural subsidies for farmers and many other agricultural services.

11- In 2017, as in the previous year, the effects of the tomato crisis with Russia dominated the markets.

12- The State Grain Board intervened in the hazelnut market after 8 years. DMO had been authorized to purchase hazelnuts for the first time in the 2006-2007 season by the Council of Ministers and after three consecutive seasons of hazelnut it resigned from the market.

13- Although production and use of Genetically Modified Organisms (GMO) is prohibited in Turkey, it was found in a loaf of bread produced in Adana.

14- Turkey imported forage again 5 years later in 2017.

15- The Republican People's Party held farming meetings in different regions of the country and carried the product-based problems of farmers on the agenda.

16- The Malatya apricot was awarded the EU geographical registration.

17- The Ministry of Food, Agriculture and Livestock published the 2018-2022 Strategic Plan.

18- The draft bill for olive fields to be opened for mining investments and reconstruction was rejected for the 7th time in the Turkish Grand National Assembly.

19- The biggest olive oil museum in the world, "Köstem Olive Oil Museum" was opened in İzmir Urla.

20- A terrible cyclone caused tens of millions of liras in Antalya.

21- Mahindra bought *Erkunt Tractor*, which is 100% domestic.

22- ChemChina bought Swiss-based *Syngenta*, one of the seed giants of the world.

23- The Sugar Foundation and the Tobacco and Alcohol Market Regulatory Authority were closed down and transferred to the Ministry of Agriculture.

SEEs TO MAKE 20 bln TL WORTH OF INVESTMENTS IN 2018

The *State Economic Enterprises (SEEs)* and the affiliated managements are envisaged to make investments worth around 20 billion TL in 2018. The Council of Ministers decision on the State Economic Enterprises and their affiliates' General Investments and Financing Program for 2018 has been published in the Official Gazette. According to the Gazette, measures will be taken to raise efficiency and profitability in all the operational activities. An effective human resources policy will be followed.

SEEs' 2018 Financial Targets

Meanwhile, State Economic Enterprises (SEEs) are envisaged to make investments worth 20.042.088 TL.

The highest one worth 7.5 billion TL will be realized by TCDD followed by BOTAŞ with 3.4 bln TL and Turkish Electricity Transmission Co. (TEİAŞ) with 2,9 bln TL. The lowest investment will be made by TETAŞ with 1.8 million TL.

State Economic Enterprises' 2018 Financial Targets (000 TL):

Enterprises and affiliates that are subject to Decree Law no 233	Investment	Borrowing Requirement (1)	Primary Surplus (2)
1 - Machinery and Chemicals Industries Co. (MKEK)	242.000	-37.767	35.567
2- Eti Mines General Directorate (ETİ MADEN")	417.000	113.312	-135.312
3- Turkish Hardcoal Enterprise Kurumu (TTK)	160.000	1.004.985	20.015
4- Turkish Coal Works (TKİ)	141.231	665.015	331.992
5- Electricity Generation Co. (EÜAŞ)	1.240.380	708.779	-815.179
6- Turkish Electricity Transmission Co. (TEİAŞ)	2.850.000	-3.040	13.954
7-Turkish Electricity Trade & Commis.Co.(TETAŞ)	1.800	-9.200	-47.030
8-Turkish Petroleum Corp. (TPAO)	1.601.000	226.314	301.575
9-Pipelines and Oil Transport Co. (BOTAŞ)	3.367.000	3.886.038	-3.936.423
10-State Grain Board (TMO)	68.508	914.740	88.895
11-Tea Works Enterprise (ÇAYKUR)	120.000	275.916	154.084
12-Agricultural Managements Gen.Direct. (TİGEM)	140.000	250.000	24.000
13-Meat and Milk Management (ESK)	48.000	-150.846	145.846
14-State Supply Office (DMO)	41.060	10.297	-115.475
15-Turkish State Railways Admin. (TCDD)	7.500.000	9.504.455	494.630
16-Turkish Wagon İnd. (TÜVASAŞ)	51.112	33.736	-33.813
17-Turkish Railways Machinery İnd. Co. (TÜDEMSAŞ)	9.300	-21.004	19.870
18-Turkish Locomotive and Motor İnd. Co. (TÜLOMSAŞ)	16.678	-7.609	7.809
19-State Airports Management (DHMI)	756.955	-362.902	298.697
20-Coast Guard General Direct. (KEGM)	86.618	-35.328	1.410
21- Turkish Electricity Distribution Co. (TEDAŞ)	75.000	49.254	-136.245
22- Turkish Electromechanics İndustry Co. (TEMSAN)	31.480	16.014	-6.164
23- TCDD Taşımacılık AŞ	953.000	1.724.884	200.000

Employment for the SEEs

In cases where it is not possible to meet the personnel requirement through intra-enterprise transfer, public entrepreneurs are obliged to transfer up to 75% of the number of the personnel that quit in 2017 by open or recruitment and up to 10% of the personnel are transferred to the State Personnel Presidency. Personnel appointment will be authorized by the board of directors of the public enterprise. Public undertakings will be able to work temporary workers only in seasonal or campaign activities, not exceeding the premium period of 179 premiums a year. The Treasury Undersecretariat will send the General Investment and Financing Program for 2018 to the public enterprises by 30 Nov. 2017. Public enterprises will prepare their 2018 operational budgets based on the program targets and submit to the Treasury Undersecretariat, Development Ministry and, based on the reference, to the Privatization Administration, by 1 Jan. 2018.

R&D Spendings Excluded from Saving Measures

R&D and innovation studies will be attached importance in the fields relevant to the activity areas, and in order to produce quality commodities and services at lower costs under market conditions, developments in production technology will be followed and a close review will be made on the informatics and communications infrastructure as well as organisational structures.

Public enterprises will be obliged to carry out all kinds of transactions related to the improvement of R&D and innovation activities, which will increase their profitability and efficiency and reduce their costs. In this framework, it will be able to work together with domestic and foreign universities or other relevant civil or public institutions or organizations.

Expenditures to be made under R&D studies will be excluded from the austerity measures.

2018 BUDGET RATIFIED

The 2018 Central Administration Budget Law and the 2016 Central Administration Final Account Law have been approved by President Recep Tayyip Erdoğan.

According to the Presidency Press Center, Erdoğan has forwarded the 2018 Central Administration Budget Law No. 7066 and the 2016 Central Administration Final Account Law No. 7067 to the Prime Ministry for publication as per Article 89 (Para.1) and Article 104 (Para.2/a) of the Constitution.

7066 in accordance with the first paragraph of Article 89 of the Constitution and the second paragraph (a) Sent to the Prime Ministr.

National Education Ministry comes third

The Ministry of Finance received an allocation of 177 bln 435 mln 423.000 TL from the 2018 budget.

While the Undersecretariat of Treasury was second with a share of 97 bln 893 mln 775.000 TL allocation, the Ministry of Education followed it with a budget of 92 bln 528 mln 652.000 TL. Allocations to the other managements:

Ministry of Labor and Social Security:
59 bln 720 mln 630.000 TL,

Ministry of National Defense:
40 bln 402 mln 239.000 TL,
Health Ministry:
37 bln 479 mln 416.000 TL,
Ministry of Family and Social Policies: 26 bln 690 mln 506.000 TL,
Security General Directorate:
27 bln 792 mln 655.000 TL,
Ministry of Food, Agriculture and Livestock:
21 bln 676 mln 673.000 TL,
Ministry of Transport, Maritime Affairs and Communications:
14 bln 945 mln 751.000 TL.

Special Budget Administrations

The Special Budget Administrations' 2018 budget:
State Hydraulic Works:
12.9 bln TL,
State Highways Administration:
18.1 bln TL,
Higher Education Credit & Hostels Ins:
13.9 bln TL,
Forestry General Directorate: 3.1 bln TL

UND PRESIDENT: CUSTOMS PROCEDURES BIGGEST PROBLEM FOR LAND TRANSPORTATION SECTOR

UND President Şener: The biggest problem of the international road transport sector is the long waiting periods in external customs and the obligation to visit the inland customs...

Fatih Şener, Chief Executive Officer of the International Transport Association (UND) has evaluated the Turkish international transportation industry.

Şener stated that, despite regional, international crisis and fluctuating oil prices in 2017, Turkey experienced the year well, adding that Turkey's exports to the relevant countries halved with the reduction of the purchasing powers of countries that subsist on oil

Many projects were postponed in Central Asia, which affected Turkish transport figures negatively. Russia has not yet normalized in terms of transport. Political tensions with Germany reflect negative outcomes.

In spite of all the environmental impacts and hitches at Turkey's western Gates, there was a 10% rise in cargoes.

Şener said, "The number of our international travels on land road increased by 6 percent during the January-October period of 2017 compared to the same period of 2016 and reached 1.030.471.

We expect that The number of international flights in 2017 will amount to 1.250.000, if we do not face a big problem."

Transportation needs to accelerating to reach the targets of 2023

Mentioning about the rates of change seen in the transportation figures, Şener drew attention to the necessity of accelerating the transportation to reach the 2023 targets.

Şener, stating that especially thanks to "One Belt One Road" Project launched by China, tremendous opportunities are expected to emerge for Turkey, said, "Turkey's 2023 export target was to reach the figure of \$ 500 billion but this deviated partially but at the moment we can not evaluate the forecast because of regional uncertainties.

However, in recent years, the tourism sector, having generated an annual revenue of \$ 25 billion, dropped its contribution to \$19.5 billion due to the crisis with Russia, and after the transportation was considered a service export, its significant contribution of \$ 15 billion became more visible.

It is possible to reach the targets of 2023 by speeding up the transportation and improving the processes. By resolving the regional crises in a way, we expect to see an increase in exports that will attract the whole world, even if it is not 500 billion in 2023."

The biggest problem is customs

Şener pointed out that the biggest problem of the international road transport sector is to have to wait for heaps of time at the external customs with the obligation to visit the inland customs.

"Recently, many companies such as those in the automotive side industry and textile sectors, have invested in the Balkans, Serbia, in order to overcome these difficulties and to be closer to the Europeans to whom they deliver their goods.

Even some European countries and the EU countries, appear to encourage small companies in the side industry to invest in the Balkans, and we see that they provide extra incentives for those that have already made investment there.

We realize that our exits from the border are faced up partly with hurdles in our processes and partly with the extra controls on the Bulgaria border.

Indeed, the customs is a problem for us at this point, and we can not get out of the gates with our existing export potential though we claim to raise our exports by 3 fold.

Actually, it takes 37 hours for a vehicle arriving at the Erenköy customs office in Istanbul to pass through kapikule.

While We plan to go to Munich within 36 hours we cannot leave Turkey within 37 hours, unfortunately."

Şener also noted that the fluctuations in fuel prices negatively affected the sector, reminding that the transportation industry's biggest expense is fuel.

THREE -LEVEL İSTANBUL TUNNEL PROJECT CONSTRUCTION TENDER TO BE HELD IN 2018

There are new developments in the 3-Level Big Istanbul Tunnel project that was auctioned by the Infrastructural Investments General Directorate of the Transport, Maritime Affairs and Communication Ministry.

Minister of Transport, Maritime Affairs Arslan said that the sea drilling works have been carried out for the 3-level İstanbul Tunnel Project. The construction will be tendered in 2018 with the build-operate-transfer model.

Arslan also said that the tunnel that will be integrated to many rail systems from İncirli' to Söğütlüçeşme will carry 6,5 million passengers daily.

Arslan noted that under the consultancy services, the sea bottom drilling works have been carried out and all the works will be completed by end of the year.

Arslan said, "The rail system which go underground at İncirli will go on undersea via Mecidiyeköy and Zincirlikuyu and entering at Söğütlüçeşme it will be connected to Kadıköy-Kartal and Marmaray. In the European side, the tunnel will go

down at Hasdal and will be United to this tunnel in the same way. Passing to the Anatolian side, it will go out at Çamlık and be linked to TEM.

This will be an important advantage for automobiles in the land road transportation.

Marmaray extends from Halkalı to Gebze in integration to all the rail systems. In the same way, this will be integrated to the rail systems between İncirli and Söğütlüçeşme. We have taken important strides in the Project. In the coming periods, we will start the process of building.."

Project Services Contract Concluded

Following a tender held on 5 April this year for the project's consultancy, engineering and Project services under file no **2016/468276**, the contract was awarded to **YÜKSEL PROJE A.Ş** quoting 28.835.000,00 TL over an estimated cost of 36.591.134,32 TL on 17 May. (DETAY-1527)

THE NUMBER OF NEWLY LAUNCHED COMPANIES RISES BY 14% IN 2017

Turkish Union of Chambers and Commodity Exchanges (TOBB) said in a report that Turkey's new business filings were up in 2017.

The number of newly launched companies in the country rose by 14.4 percent year-on-year in 2017

TOBB said 72,871 companies were established last year, up from 63,709 in 2016. The report showed that 13,517 companies went out of business in 2017, marking a 22.5 percent increase compared to the previous year. Of the total companies and cooperatives established, 2,012 were involved in wholesale and retail trade, repair of motor vehicles and motorcycles, 937 construction and 775 in the manufacturing sector. Of the real persons commercial enterprises that are established, 506 of them are engaged in wholesale and retail trade, repair of motor vehicles and motorcycles, 785 of construction and 563 of manufacturing.

688 of the closed companies and cooperatives were involved in wholesale and retail trade, repair of motor vehicles and motorcycles, 353 in construction, 278 in manufacturing. It is seen that 695 of the real person commercial enterprises were in the wholesale and retail trade, repair of motor vehicles and motorcycles, construction of 316, and transport and storage of 142. In December, 77 cooperatives were established.

The number of newly established foreign-partnered or foreign-funded companies jumped by 49 percent to reach at 6,731 during the same period.

The figure was 4,523 in 2016.

The report indicated an annual rise of 22.9-percent in the number of newly launched companies in December alone, reaching 4,818.

Also in December, a total of 717 foreign-partnered companies were established, the report added.

NUMBER OF CARS IN FLEET REACHES 346.000 UNITS

The asset size of the Operational Leasing Sector has exceeded 26 billion liras. In January-October 2017, 95.500 new automobiles were purchased and thus, the total number of vehicles reached 346.600units.

A growing awareness in Turkey of the advantages of operational leasing is attracting new customers and growing the market. Growing awareness on the advantages of operational leasing, renting instead of buying, is attracting new customers. According to the "Operational Leasing Sector Report in Turkey" by the Turkish Short and Long Term Automotive Rental Association, the total number of operational leasing vehicles in Turkey reached 207,000 in 2013 an increase of 37,000 from 2012.

The figures have recently boom further. In the first nine months of 2017, The Operational Leasing Sector added about 95.500 of the new cars sold in Turkey into its fleet out, which make up 20 percent of the total new car sales. In January-October 2017, the asset size of The Operational Leasing Sector, which invested approximately TL 8.5 billion in new vehicles, exceeded TL 26 billion, while the number of vehicles in the fleet reached 346.600 units.

According to the results of TOKKDER's* market research conducted in cooperation with TNS Global in the third quarter of 2017, the lease sector paid approximately 4 bln 501 mln TL worth of taxes in the first 9 months of 2017. The sector contributed to the country's economy by paying taxes of approximately 4 bln 950 mln TL in 2016. In the 2016 first quarter, where the new passenger car sales in Turkey increased by 0,3 % compared to the 2015 same period (*Source: ODD*), Turkish operational leasing sector added approximately 24.600 new vehicles to its fleet which is equivalent to 19,2% of the new passenger cars sold in Turkey in this year. The vehicle fleet of the Turkish operational leasing sector reached approximately 276.400 units. The change in the number of customers of the sector and the number of passenger car per customer. The number of customers of the sector reached 44.782 by an increase of %24 compared the previous year same period. The number of vehicles per customer falls every year. In 2016 first quarte the figure fell to 5,8 from 5,9 compared to 2015 end year.

This data indicating SMEs as well, prefer operational leasing method to acquire company vehicle fleet, alongside the multinational and local companies. By the end of the research period: Renault in Turkey with the share %30,2 in the car park of operational leasing sector continues to be the most preferred brand, Renault followed by VW with %16,2 and they followed by Ford with %11,7, Fiat with %9,2 Half of the car park sector (%52,5) C segment, whereas B segment %28,5, %12,5 is D segment.

International companies have been benefiting from the advantages of long-term leasing for many years. In recent years, SMEs (KOBİ) and individuals have begun to explore the operational leasing method and the facilities they provide. Thus many SMEs are renting the fleet instead of buying. Operational leasing offers many advantages to every business and to individuals in terms of efficient use of resources and productivity. These advantages are: Vehicle allows you to meet your needs without using equity. Thus, credit limits and other equity allow you to grow your business.

Vehicle tax label, vehicle inspection and similar tax-based payments cannot be shown as an expense when you own the vehicle. However, thanks to the lease, businesses can write the VAT item in the rental bill as an item of expense. While you can plan your cash flow because the rental rates are regular and stable, you can also get rid of the surprise expenses. Tax label, traffic insurance, insurance, kasko and tax transactions are paid by the fleet rental company.

Hybrid And Electric Auto Era

The car park of the operational fleet leasing sector in Turkey consists mainly of diesel vehicles. This rate was 94.9 percent in the January-October period of 2017. But there is a different development in the world. Corporate companies have begun to prefer electric and hybrid vehicles to lower their carbon footprint and reduce fuel costs.

***TOKKDER:** Founded in Istanbul in 1996 to integrate rent-a-car and car leasing companies under the same roof. Vision is to be the only protector and the reference of the operational leasing and rent a car industries acting in perfect harmony with the laws and state policies, with high level of professionalism and ethical values, in order to provide better services to customers.

JOINT VENTURE SET UP TO PRODUCE FIRST DOMESTICALLY-PRODUCED CAR

President Erdoğan announced the five companies to produce the first domestic car at the meeting "Turkey's Automobile Joint Venture Group Promotion"..

Turkey's indigenous car to be manufactured by a joint venture comprising Turkcell, BMC, Kıraca Holding, Zorlu Holding, Anadolu Group..

Turkey launched a joint venture of five local industrial giants to produce its first domestically-made car on last week. Five suppliers - Anadolu Group, BMC, Kıraca Holding, Turkcell, and Zorlu Holding - will jointly manufacture Turkey's first indigenous car.

At the ceremony at the presidential palace in Ankara, President Recep Tayyip Erdoğan expressed his gratitude to the firms and promised his "full support" for the venture.

Prime Minister Binali Yıldırım also delivered a speech to mark the launch of the landmark venture. The initiative came after repeated calls from Erdoğan for a joint project of the Union of Chambers and Commodity Exchanges (TOBB) and the Science, Industry and Technology Ministry.

Erdoğan said he expected the prototype of first domestically-produced car to be ready in 2019 and for sales to start in 2021. "I want to own the first such automobile and I will pay for it," he said, adding that he would prefer a hybrid or an electric car option.

Erdoğan also said that the initiative group of Turkey's automobile will decide on the class, design, engine technology, model, production method and market targets for the car.

He said that they could also lean toward producing hybrid and electric cars, indicating that regardless of the decision, they will provide all kinds of support as long as the Turkish nation is adequately equipped to realize its dream.

For his part, Yıldırım praised the "bravehearts" who will carry out the project. "Turkey has the engineers, technicians, workers and bravehearts necessary. And they will have the state backing them," he said.

Also speaking at the ceremony, TOBB chairman Rifat Hisarcıklıoğlu said it was the "right time" for a 100 percent Turkish automobile.

"Century-old automobile giants are racing with each other in new-generation car technologies. So now is the right time for the Turkish automobile. We will work very

hard for three or four months to analyze the alternative technologies and funding options," Hisarcıklıoğlu said.

Anadolu, BMC and Kıraca are already directly involved in car manufacturing, while Turkcell is the country's largest mobile operator and will engage in the project for technological support. Zorlu is a multi-sector conglomerate, which manufactures computers and white goods along with many other businesses.

Science, Industry and Technology Minister Faruk Özlü said that the government's goal for the country's first domestically produced automobile is for it to hit the road around the world.

Özlü said they are aiming for worldwide success with the project and there is no obstacle for Turkey not to realize its half-century-old dream.

"We are carrying out serious work and we hope we will complete Turkey's automobile at the previously set time. Our goal for the automobile is for it to make an appearance not only in Turkey, but on global roads as well. We aim a global success with this project. We are thinking of manufacturing a car not only for Turkey, but for the whole world," he said.

The minister added that the automobile is being projected according to the new realities of the automotive world along with the changing industrial structure.

"The era of the internal combustion engine is about to end. Henceforth, electric cars are the future. On this path we are taking, we aim to catch the future. Our car will run on electricity.

I believe we have chosen the right time for the electric car.

Our president's instruction in terms of timing was a very good decision. Ours is to put it into practice. The intellectual property rights of the prototype for Turkey's automobile will belong to our country.

These vehicles will be a kind of walking software," he said.

"Our 2023 goal is not the ultimate goal for us, but an intermediate goal we have set in order to reach our main goal.

A Turkey that has realized its 2023 targets will go toward its 2071 targets with much more confident steps. We have pursued our work with this consciousness, and we will continue to do the same."

INVESTMENTS IN WIND POWER (RES) EXCEED \$1 BLN

There has been two fold interest in investments in wind power as being one of the Renewable Energy Resources in the last 11 years. RES projects that had 146 MW capacity in 2007 reached a capacity of 6500 MW in 2017..

According to the Turkish Wind Energy Association (TÜREB), about 8 percent of the electricity produced in Turkey is obtained from wind energy. There are currently 158 companies in operation in this sector and 32 projects are at the stage of building with a total installed capacity of 808 MW.

Izmir, which has a 20.5 percent share of the wind energy power, occupies the first place with an installed capacity of 333 MW. This is followed by Balıkesir, where 16.5 percent (1.069 MW) of the existing wind power plants is located, and then Manisa having a share of 10 percent with 650 MW capacity.

5 -day bidding sessions

Tenders were held between by the Turkish Electricity Transmission Co. (TEİAŞ) 25-29 December 2017 regarding the allocation of pre-licences for construction of wind power plants.

On December 25, 2017, proposals were received for 8 regions with a total pre-license of 430 MW. 101 companies had applied. Contracts were awarded to more than one sharing the total MW:

06 / Amasya – Samsun (Total 60 MW)

49 MW (of the 60 MW capacity):

-0,88 \$ cent/kWh, Doğages Elektrik Üretim Anonim Şti.'s Doğages RES Project,

11 MW part: -0,55 \$ cent/kWh, Ekores Enerji Elektrik Üretim Anonim Şti.'s Taşova RES Project,

23 / Çorum – Kastamonu – Sinop (Total 70 MW)

5 MW part: -0,71 \$ cent/kWh, Ekores Enerji Elektrik Üretim Anonim Şti.'s Kozcu RES Project,

65 MW part: -0,66 \$ cent/kWh, Res Anatolia Holding Anonim Şti.'s Topaz RES Project,

08 / Antalya (Total 100 MW)

50 MW part: -1,18 \$ cent/kWh, Enyat Enerji Yatırımları Elektrik Üretim Tic. AŞ.'s Alanya RES Project,

10 MW part: -0,57 \$ cent/kWh: Dere Enerji AŞ D3 RES Project,

10 MW part : -0,48 cent/kWh, D1 RES Project,

-0,48 cent/kWh,. 20MW part (each 10 MW): 30 MW: -0,52 cent/kWh, Akhisar Enerji AŞ Dökükdağı RES Prj,

18 / Bitlis – Muş (Total 40 MW)

20 MW part: 7,10 \$ cent/kWh, Difer Enerji Sanayi Ve Ticaret Anonim Şti.'s Miskevank RES,

20 MW part: 6,95 \$ cent/kWh, Beres Elektrik Üretim Anonim Şti.'s Örenlik RES Project,

19 / Bolu – Düzce – Sakarya (Total 30 MW)

All of the 30 MW capacity: 3,78 \$ cent/kWh, Günışığıges Elektrik Üretim A.Ş.'s Günışığıges RES Prj,

25 / Elazığ (Total 40 MW)

All of the 40 MW cap.: -0,63 \$ cent/kWh, Buca Rüzgar Güneş Yenilenebilir Enerji ve Elektrik Üretim A.Ş.'s Buca RES Project,

28 / Gaziantep – Kilis (Total 40 MW)

All of the 40 MW capacity: -1,63 \$ cent/kWh, Lacivert Yenilenebilir Enerji Ve Elektrik Üretim Anonim Şti.'s Lacivert RES Project,

31 / İstanbul (Total 50 MW)

49,5 MW part: -1,71 \$ cent/kWh, Gelgit Yenilenebilir Enerji's Gelgit RES Project,

0,5 MW part: -0,65 \$ cent/kWh, Polat Enerji's İstanbul RES Project,

Bidding date: 26.12.2017

On the 2nd day of the biddings, a total of 350 MW capacity was allocated for 8 regions.

The winners and their projects are as follows;

Contract awards were made to more than one firms that have shared the total MW given.

02 / Adıyaman (Total 40 MW)

Of the 40 MW capacity 20 MW part: -1,40 \$ cent/kWh, Errol Enerji's Arıkonak RES Project,

20 MW part: -0,77 \$ cent/kWh \$ cent/kWh, Özgül Lilyum Yenilenebilir Enerji's Lilyum RES Project,

09 / Ardahan – Kars (Total 40 MW)

20 MW part: 7,29 \$ cent/kWh, Ceres Elektrik Üretim Anonim Şirketi Gümüştepe RES The rest 20 MW part: No allocation as only one bid came in.

26 / Erzincan (Total 50 MW)

50 MW capacity: 48 MW part: -1,33 \$ cent/kWh, Arapgir A.Ş.'s Arapgir RES

2 MW portion: 6,20 \$ cent/kWh, Bengü Enerji Üretim Sanayi Ve Ticaret Anonim Şti's Bengü RES Project,

39 / Malatya (Total 80 MW)

80 MW capacity: 30 MW part: -1,81 \$ cent/kWh, Tunna Enerji Üretim Sanayi Ve Ticaret A.Ş.'s Gülümuşağı RES Project, 50 MW part: -1,22 \$ cent/kWh,

Sandal Yenilenebilir Enerji A.Ş.'s Sandal RES Project.

29 / Hatay (Total 30 MW)

30 MW capacity: -1,83 \$ cent/kWh, Böğürtlen Yenilenebilir Enerji Ve Elektrik Üretim Anonim Şti's Böğürtlen RES Project,

33 / Kahramanmaraş – Osmaniye (Total 40 MW)

Of the 40 MW capacity 20 MW part: -0,90 \$ cent/kWh, Güney Res Enerji's Tanır RES Project,

20 MW part: -0,60 \$ cent/kWh, Ak Jeo Enerji pW-TR1002 RES Project,

37 / Kocaeli – Yalova (Total 40 MW)

All of the 40 MW capacity: -1,41 \$ cent/kWh, Karanfil Yenilenebilir Enerji Ve Elektrik Ür. A.Ş.'s Karanfil RES Prj.

47 / Yozgat (Total 50 MW)

30 MW portion: -1,58 \$ cent/kWh, Sandeks Enerji's Beyyurdu RES Project, 20 MW portion: -1,21 \$ cent/kWh, Menekşe Yenilenebilir Enerji's Menekşe RES Project,

Bidding date: 27.12.2017

On the 3rd day, capacities were allocated for 6 regions. The winners and their projects are as follows;

04 / Ağrı – Iğdır (Total 50 MW)

Of the 50 MW capacity, 20 MW part: 7,27 \$ cent/kWh, Kocatepe Arslanlar Elektrik's İpektepe RES Project, 30 MW part: 7,29 \$ cent/kWh, Knot Enerji's Yakaağzı RES Project,

13 / Bartın – Zonguldak – Karabük (Total 30 MW)

30 MW capacity: -0,15 \$ cent/kWh, Yağmur Res Enerji Yatırım Üretim Ve Ticaret Anonim Şti's Karabük RES Project,

14 / Batman – Mardin – Diyarbakır – Şanlıurfa

60 MW capacity: -1,12 \$ cent/kWh, Uranüsgeş Elektrik Üretim Anonim Şti.'s Uranüsgeş RES Project,

15 / Bayburt – Gümüşhane – Giresun (Total 40 MW)

Of the 40 MW capacity, 30 MW part: -0,12 \$ cent/kWh, Ömer Enerji's Ömer RES Project,

10 MW portion: 7,29 \$ cent/kWh, Eysel Global Elektrik Üretim Anonim Şti.'s Erimez RES Project,

21 / Bursa (110 MW)

45 MW: -1,41 \$ cent/kWh, BER Enerji's Yarış RES Project, 15 MW: -1,05 \$ cent/kWh, Işık Res Enerji's Yalova RES Project, 30 MW: -1,05 \$ cent/kWh, Umut Res Enerji's Kiraz RES Project, 10 MW: -1,05 \$ cent/kWh, Baysal Elektrik'in Çepni RES Project, 10 MW part: NTP Elektrik's Mesudiye RES Project.

27 / Erzurum (Total 50 MW)

50 MW capacity: 5,64 \$ cent/kWh, Yel Rüzgar Enerjisi Yatırımları A.Ş.'s Nenehatun RES Project,

34 / Karaman – Mersin (Total 250 MW)

Of the total capacity, 124.2 MW part: -2.13 \$ cent/kWh, Polat Enerji's Karaman RES,

49,5 MW: -1,59 \$ cent/kWh, Makif Rüzgar Güneş Yenilenebilir Enerji's Makif RES Project,

49,5 MW: -1,53 \$ cent/kWh, Sarmaşık Yenilenebilir Enerji's Sarmaşık RES Project,

12 MW portion: -1,69 \$ cent/kWh, Cerenges Elektrik A.Ş.'s Cerenges RES Project,

14.8 MW portion: -1,52 \$ cent/kWh, Polat Enerji

Sanayi ve Ticaret Anonim Şti.'s Mersin RES

Bidding date: 28.12.2017

Connection capacity has been allocated to 740 MW' more projects.

TEİAŞ completed the 740 MW' portion, the final stage, of the 2130 MW' wind power allocation/pre-licencing tenders. 409 bids were in for 685 projects. Of the 2.130 MW capacity, 2.110 MW portion has been allocated to firms.

Thus, 76 projects have received allocations of capacity in 32 different locations.

The winners and their projects are as follows;

Afyonkarahisar (Total 30 MW)

Of 11 applicants, 9 submitted bids:

23,4 MW portion: -1,89\$/kWh, Polat Enerji A.Ş.'s Karahisar RES Project, 6,6 MW portion: -1,25\$/kWh, Hatmi Yenilenebilir A.Ş.'s Hatmi RES Project

Isparta (Total 60MW)

All of the 60MW: -1,69\$/kWh, Şule Enerji A.Ş.'s Şule RES Project,

Burdur-Denizli-Uşak (Total 50 MW)

Of 20 applicants, 9 submitted bids:

47 MW capacity: -1,49\$/kWh, Batires A.Ş.'s Batires RES Project 3 MW capacity: -0,69\$/kWh, Alternatif Res A.Ş.'s Günalan Project..

Aydın-Muğla (Total 50MW)

Of 31 applicants, 16 submitted bids:

49,5 MW part allotted at: -2,23\$/kWh, to: Lodos Yenilenebilir A.Ş.'s Lodos RES Project

0,5 MW part allotted at: -2,02\$/kWh, to: Ekores Enerji A.Ş.'s Bodrum1 RES Project

Konya (Total 50 MW)

Of 18 applicants, 8 submitted bids:

30MW part allotted at: -1,19\$/kWh, to: İdilres A.Ş.'s İdil RES Project, 20MW part allotted at: -0,56\$/kWh to: Res Anatolia A.Ş.'s İmrenler RES Project,

İzmir (Total 50 MW)

Of 37 applicants, 23 submitted bids:

All of the 50 MW capacity: -2,51\$/kWh, Polat Enerji A.Ş.'s SarıcaRES Project,

Balıkesir (Total 160MW)

94 applications were received, and 54 submitted bids: 9,9 MW part: -2,57\$/kWh, Sarı Kanat Enerji A.Ş.'s Balya RES Project,

150,1 MW part: -2,51\$/kWh, Polat Enerji A.Ş.'s Duygu RES Project.

Çanakkale (Total 260MW)

99 applications were received, and of them 59 submitted bids. The total capacity has been shared by:

71,4 MW portion: PNE Wind Ltd. Şti.'s Köşeler RES Prj., (-2,87\$/kWh) ,

99,9MW portion: Polat Enerji A.Ş.'s Çınar RES Project, (-2,42\$/kWh) ,

10 MW portion: Selin5 Enerji A.Ş.'s Selin5 RES Project, (-2,81\$/kWh) ,

10 MW portion: Selin4 Enerji A.Ş.'s Selin4 RES Project, (-2,71\$/kWh),

10 MW portion: Selin3 Enerji A.Ş.'s Selin3 RES Project, (-2,70\$/kWh),

40 MW portion: Yakın Yenilenebilir Ltd. Şti.'s Ayça RES Project, (-2,11\$/kWh),

5MW: Merkom Enerji A.Ş.'s Yel Değirmeni RES Project (-2,35\$/kWh),

9,9 MW: Balay Enerji A.Ş.'s Gönen RES Project (-2,10\$/kWh),

3,8 MW portion: KeremRES Elektrik A.Ş.'s Kerem RES Project, (-2,09\$/kWh),

Manisa (Total 30MW)

23 applications were received, and of them 14 submitted bids. All of the 30 MW capacity has been contracted to: Düzce Rüzgar Yenilenebilir A.Ş.'s Düzce RES Project, at a cost of -2,02\$/kWh.

Latest wind power tenders

Around 300 projects of 10.000 MW capacity contested in 11 regions. Within 3 days, an allocation of 710 MW would be made for 11 regions. Tenders were held on 21-22-23 June 2017 regarding the 710 MW part of the allocation of the 3.000 MW RES capacity, for which applications had been received in April 2015 (DETAY-1531). When the subject plants are put into operation, the wind power capacity is supposed to rise by 12.5%. Below are the tenders held recently:

21 June tender...

35 / Kayseri-Niğde (80 MW)

01 / Adana (120 MW)

07 / Ankara-Kırıkkale-Çankırı (60 MW)

05 / Aksaray-Kırşehir-Nevşehir (60 MW)

A total of 320 MW' capacity was tendered.

Winners :

Kayseri-Niğde (80 MW):

-Esengüç Enerji, Ovacık RES, -0,01 \$ cent/kWh, 15 MW

-Enerjisa Enerji, Erciyes RES, 2,90 \$ cent/kWh, 65 MW

Adana (120 MW):

-Akdeniz RES Enerji, Mansurlu RES, 4,74 \$ cent/kWh, 60 MW

-CNG Enerji, Andoz RES, 4,78 \$ cent/kWh, 32 MW

-Atasa RES Enerji, Atasa RES, 5 \$ cent/kWh, 23,4 MW

-Günyeli RES, Saimbeyli RES, 5,12 \$ cent/kWh, 4,6 MW

Ankara-Kırıkkale-Çankırı (60 MW):

-Simge RES Elektrik, Beypazarı RES, 4,18 \$ cent/kWh, 20 MW

-Jüpiterges Elektrik, Jüpiterges RES, 4,19 \$ cent/kWh, 40 MW

(Lowest bid price, -0,12 \$ cent/kWh quoted by Kires Elektrik. However, a capacity allocation has not been made to the firm as its project overlapped with the others).

Aksaray-Kırşehir-Nevşehir (60 MW):

-RES Anatolia Holding, Opal RES, -1,15 \$ cent/kWh, 60 MW

Tenders held on 22 June 2017...

24 / Edirne (40 MW)

44 / Tekirdağ (60 MW)

36 / Kırklareli (70 MW)

The 2nd round of the tenders opened by TEİAŞ for 710 MW wind power allocations was held on 22 June 2017, when the following firms contested:

Edirne (40 MW- 32 firms participated):

-Fesleğen Yenilenebilir Enerji, Fesleğen RES, -1,51 \$ cent/ kWh, 40 MW

Tekirdağ (60 MW -36 firms participated):

-Kaktüs Yenilenebilir Enerji, Kaktüs RES, - 1,49 \$ cent/ kWh, 49,5 MW

-Buket Yenilenebilir Enerji, Buket RES, -1,48 \$ cent/ kWh 10,5 MW

Kırklareli (70 MW- 34 firms participated):

-Res Anatolia Holding, Elmacık RES, - 1,61 \$ cent/ kWh, 70 MW

23 June 2017 tenders...

43 / Sivas (80 MW)

45 / Tokat (40 MW)

41 / Ordu (50 MW)

16 / Bilecik-Eskişehir-Kütahya (50 MW)

Pelit RES has received the allocation of all the 80 MW capacity in Sivas out of the 220 MW in the regions of Sivas, Tokat, Ordu and Bilecik-Eskişehir-Kütahya. The firm has quoted - 0.81 cent/kWh

Baysal Elektrik's Bayır RES has received the allocation of the 100 MW capacity in Ordu quoting -0.37 cent/kWh, the lowest of all. The rest 40 MW portion has been awarded to **Özgül Kamelya's Kamelya RES**.

23 projects contested the 40 MW cap. in Tokat Region. **GRGN Rüzgar Enerji Santrali Projesi** has received the allocation with a bid offer of -0.33 cent (dollar) per kWh

24 projects contested the 50 MW cap. in Bilecik-Eskişehir-Kütahya. **RES Anatolia** received with an offer of -1.03 cent (dollar) per kWh below the market price

YEKA tender held on 3 August 2017...

The tender for Renewable Energy Resource was also concluded. **Siemens-Türkerler-Kalyon Enerji** won a \$1bn tender, with the lowest price of \$3.48 cent/KWH per kilowatts. (DETAY-1537).

2018 INVESTMENT PROGRAM'S PROJECT VALUE 804.6 BLN TL

The İstanbul Metropolitan Municipality's Assembly ratified the Metropolitan Municipal draft budget worth 20 billion 100 million TL for 2018. The Municipality Assembly debated the Metropolitan Municipality's Performance Program for 2018, the Investment and Services Program for 2018, the 2018 Financial Year Budget, and the Revenue-Expenditure Forecasts for the periods of 2019-2020.

Mayor Mevlüt Uysal submitted the 2018 Budget Draft to the Municipal Assembly members during the meeting chaired by Municipal Vice President Gökşel Gümüşdağ. Mayor Uysal said, "Together with İSKİ, İETT and companies, our consolidated budget has reached an amount of 42,6 billion. We prepared an investing budget with principle of little talk but a lot of business.". Mayor Uysal pointed out during the meeting that they are aware of the responsibility İstanbul imposes on them and that they are working on a budget that will meet the needs of the city. He said, "We have determined the municipal budget of the year 2018 as 20 billion 100 million liras. This figure is an increase of 8.65 percent compared to the past year. When we add İETT, İSKİ and our affiliates to the budget of the Metropolitan Municipality, the overall budget reaches a figure of 42 billion 600 million TL. Our investments in 2018 have a total value of 16 billion 113 million liras with the addition of our companies and affiliates are included. This shows that our budget draft is exactly for investment purposes, as we wish to make the greatest investment as much as possible in the future of İstanbul."

İBB's Fiscal Structure is strong

Mayor Mevlüt Uysal said that the revenue budget is 16 billion 250 million liras, and that the revenue-expenditure balance will be made possible through the internal and external borrowings. "This year, a 3 -billion 850 -mIn lira worth of borrowing has been envisaged in the budget that is composed of the usage and payment differences. The debt due to be paid within the year is 2 billion 570 million TL. However, the 1 billion 370 million TL part of these debt will be paid for the previous borrowings received from İSKİ and İGDAŞ in the past years. Uysal said, "When we drop off these, the figure we will have to pay decreases to 1 billion 200 million liras for this year. So the debt we are due to pay makes up the 8 percent of our revenues. An important part of the source that was created through borrowing will be used for rail system investments.."

Greater Share of Investment for Transport

Uysal stated, "We will continue to build our future by multiplying these investments together.", and added that their target is to create an İstanbul that is constantly renewed, planned, developed, with an increasing attraction.

The Mayor, noting that the basic principles of transportation are "to integrate all transportation systems" and that for this reason, the lion's share of 6 billion 822 million TL is allocated to transportation. Uysal underlined that İstanbul has about 500 vehicles launched into traffic each day. "It's so high.

If we allot the private vehicles to transport, we cannot get over it. For this reason, we focus on transporting the people, not the vehicles. And the most efficient way to do this is rail systems." he said.

Uysal went on to say, "We are trying to build the rail systems expanding up to the neighborhood. For example, the Eminönü-Alibeyköy tram line Alibeyköy, which will carry 114.000 passengers per day with 14 stations will solve the traffic problem and make the Eyüp Sultan a full attraction center. So we are now taking trams to up to the places where no minibuses were available before.

The Üsküdar- Çekmeköy- Sancaktepe Line, Turkey's first driverless metro line, has come to an end. The Üsküdar-Yamanevler is opening within 15-20 days.

We have cancelled the Sefaköy-Başakşehir Havaray Line Project and started to build a subway instead. We are connecting this line with the Aksaray-İkitelli Line at Mimar Sinan Station, with the Kirazlı-Halkalı Line at Halkalı Center, and with the Mecidiyeköy-Mahmutbey Line at Mehmet Akif Station. We currently have a total 150-km rail system line that is in service in the city. When we add a 115-kilometer line, which was tendered by the Ministry of Transportation, to the 160-kilometer metro line, which is under construction after being tendered by the municipality, a total of 275 km new rail system is being built in İstanbul.

We know that problems will be solved when the rail system in İstanbul goes up to a total length of 1000 km.

"He said, "In highway systems, we completed 215 junctions. Construction of 18 intersections continues."

İZMİR ESHOT'S BUDGET RATIFIED

The ESHOT General Directorate's 2018 budget was ratified as 875 million TL with an increase of 17 percent. **Mayor Aziz Kocaoğlu** gave thanks to the employees of ESHOT, who played a role as a backbone in urban transportation, giving good news that 90 minutes of speculation will not be applied and 100 vehicles will be added to the fleet. The 2018 Fiscal Year Performance Program and Income-Expenditure Budget prepared under the framework of ESHOT's 2015-2019 Strategic Plan, which undertook most of the public transportation burden in Izmir, was presented to the approval of the Metropolitan Municipal Assembly.

While the performance program and the budget were accepted by the majority votes of the members of the parliament, the ESHOT's budget, which was 746 million liras in 2017, was increased by 17 percent to 875 million 697 thousand liras.

Mayor Aziz Kocaoğlu stated at the meeting that the fleet will add 100 new vehicles and that their 90-minute practice will continue. Kocaoğlu said, "The Izmir

Metropolitan Municipality, together with its companies, subsidizes transportation with not 300 million, not 500 million, but with a budget of 600 million TL.

The ratio in Istanbul is twice this size. A special inspection is needed on why we suffer loss from transportation.

The cost is 2,75 TL for wheeled transport..To say that it is a 'waste' is a separate issue.

Then the central government will come up with a law stipulating that transportation companies have to reflect the cost to the ticket."

The Mayor also said that the cost of purchasing electric buses is 2.5 times more than other buses. The ESHOT, which allocates 70 million TL of the 2018 budget to new articulated and solo bus purchases, will build new garages at different points of the city for buses, while modernizing its existing service units.

The number of card-filling machines will also be increased to facilitate and promote the use of contact-free smart cards

GAZİANTEP METROPOLITAN MUNICIPALITY'S 2018 BUDGET DISCLOSED

The Gaziantep Metropolitan Municipality's Assembly convened and Municipal Fiscal Budget for 2018 was determined as 1 billion 550 million TL.

The Assembly debated 88 items on the agenda and accepted 60 of them by the majority of votes.

The 2018 municipal budgets of the Gaziantep Metropolitan and the districts of Şahinbey, Şehitkamil, Nizip, İslâhiye, Yavuzeli, Oğuzeli, Nurdağı Araban and Karkamış were ratified at the Assembly.

The district municipalities' spending and revenue budgets:Şahinbey Municipality's Spending Budget 830 million TL, Revenue Budget 830 million TL, Şehitkamil

Municipality's Revenue Budget 500 millionTL, Spending 650 million TL, Nizip Municipality's Revenue Budget 75 million TL, Spending 75 millionTL, Nurdağı Municipality's Revenue 37 mln 917.000, Spending 37 mln 917.000 TL, Oğuzeli Municipality's Revenue 32 million TL, Spending 32 million TL, İslahiye Municipality's Revenue 31 mln 371.000TL, Spending 31 mln 371.000TL, Araban Municipality's Revenue 14 mln 530.000TL, Spending 14 mln 530.000TL, Yavuzeli Municipality's Revenue 14 mln 560.000TL, Spending 14 mln 560.000TL and Karkamış Municipality's Revenue 10 mln TL, Spending 10 mln TL.

FISCAL YEAR BUDGETS OF İSTANBUL'S 39 DISTRICTS FOR 2018 RATIFIED

The İstanbul Metropolitan Municipality's Assembly has accepted the financial budgets of the 39 provinces in 2018 totaling 20 billion 871 million 997 TL.

The Municipal Assembly approved the 2018 financial budget of the 39 districts. At the Assembly meeting in the Saraçhane settlement, the budgets of the district municipalities were also discussed after the 2018 fiscal budget was approved.

Accordingly, Esenyurt Municipality appears with the highest budget with an amount of 1 billion 500 thousand TL, followed by Kadıköy with 635 million TL, Beylikdüzü with 627 million 35 thousand TL and Şişli with 610 million TL.. Adalar Municipality appears with the lowest budget of 42 million TL followed by Çatalca Municipality with 61 mln TL.

The İstanbul Metropolitan district municipalities' 2018 budget allocations:

- Maltepe 398 million TL 860.000TL
- Küçükçekmece 570 million TL TL
- Bağcılar 480 million TL TL
- Esenyurt 1 billion 500.000TL
- Silivri 230 million TL TL
- Esenler 320 million TL TL
- Bakırköy 465 million TL 832 bin TL
- Çatalca 61 million TL TL
- Bayrampaşa 265 million TL TL
- Arnavutköy 310 million TL TL
- Zeytinburnu 388 million TL TL
- L 500.000TL
- Şişli 610 million TL TL.
- Kartal 506 million TL TL
- Beykoz 513 million TL TL
- Beylikdüzü 627 million TL 35.000TL
- Sultangazi 402 million TL TL
- Tuzla 325 million TL TL
- Beyoğlu 295 million TL TL
- Bahçelievler 360 million TL 822.357 TL
- Başakşehir 529 million TL 100 bin TL
- Gaziosmanpaşa 435 million TL TL
- Üsküdar 550 million TL TL
- Çekmeköy 255 million TL TL
- Kadıköy 635 million TL TL
- Sancaktepe 550 million TL TL
- Ataşehir 550 million TL TL
- Sarıyer 390 million TL 87.000TL
- Büyükçekmece 377 million TL TL
- Adalar 42 million TL TL
- Avcılar 310 million TL TL
- Sultanbeyli 252 million TL TL
- Şile 75 million TL TL
- Güngören 211 million TL 800.000TL
- Eyüpsultan 414 million TL TL
- Fatih 336 million TL 209.640 TL
- Kağıthane 363 million TL 398.000TL
- Pendik 510 million TL TL
- Ümraniye 500 million TL TL
- Beşiktaş 528 million TL.

ANKARA METROPOLITAN MUNICIPALITY PLANS TO PROCURE 123 VEHICLES IN 2018

The Ankara M.Municipality is planning to procure a total of 123 units of vehicles and machines in 2018 to meet the requirements of its departments, as included in the *2018 Investment Program*.

Procurements will be made in accordance with the Transport Vehicle Law no 237.

Below are the procurements and the municipal departments that require the vehicles:

Double cab small truck	5 ea	Fen İşleri Dairesi
Connect combi type	1 ea	Zabıta Dairesi
Pick-Up (4x4) double cabin	3 ea	
Minibus	3 ea	
Road sweeper	5 ea	Kent Estetiği Dairesi
High-press. First intervention vehicle installed on 4x4 Pick-Up	10 ea	İtfaiye Dairesi
Multipurpose fire fighting truck	10 ea	
Fire fighting vehicle with 42 m. full automatic ladder	10 ea	
Rescue tool	2 ea	
Double cab small truck	10 ea	
fire fighting water tanker	10 ea	
Foam tower	2 ea	
Tree-deplanting machine	1 ea	Çevre Koruma Dairesi
Gantry crane	1 ea	
Ambulance	5 ea	Sağlık İşleri Dairesi
Off-road vehicle (Volkswagen-Amarok)	1 ea	Sağlık İşleri Dairesi
Hearse (Ford)	2 ea	Sağlık İşleri Dairesi
Funeral washing vehicle (Ford)	1 ea	
Minibus	1 ea	
Animal transport vehicle	1 ea	Veteriner Şb. Müdürlüğü
Minibus (15 + 1)	10 ea	Destek Hizmetleri Dairesi
Truck and maintenance vehicle	1 ea	Makine İkml.Bakım Onr. Dairesi
4x4 off-road vehicle	1 ea	Kırsal Hizmetler ve Jeotermal Kaynaklar Dairesi
Truck	10 ea	Kültür ve Sosyal İşler Dairesi
TIR Truck	10 ea	
Minibus (Volkswagen Carevelle 2.0. TDI Comforline)	2 ea	Basın Yayın Halkla İlişkiler Dairesi
Atlas long-haul truck	1 ea	Sosyal Hiz. Dairesi
TOTAL: 123 UNITS		

ANKARA METROPOLITAN MUNICIPALITY'S EGO AND ASKİ 2018 BUDGETS RATIFIED

Ankara Metropolitan Mayor Assoc. Dr. Mustafa Tuna said, "We need to ban the sale of dogs to pet shops." President Tuna, who chaired the Metropolitan Municipality's 2018 Fiscal Year Budget meeting, firstly made evaluations on the recommendations of the assembly members. Tuna said, "There are various opinions about street animals, and we need to find a permanent solution to this situation.

Tuna said that they will meet with district municipalities and expert teams and take joint decisions on how to manage street animals. "We have to ban animal sales in pet shops. I also think that selling an

animal, as a goods, is not accurate. That means it's not a pen, a book, a shoe.

The animal is a living thing. You enslave her. I do not have to sell it like that." Tuna noted.

Following the assessment talks before the budget meeting, the Metropolitan Municipality, ASKİ, EGO 2018 Fiscal Year Budgets were ratified.

After the debates, the Metropolitan Municipality Assembly approved with unanimity the Metropolitan Municipality's 2018 Fiscal Year Budget as 8 billion 10.000TL, ASKİ's as 3 billion TL and EGO's as 990 million TL.

SAKARYA METROPOLITAN MUNICIPALITY'S VEHICLE PROCUREMENTS IN 2018

The Sakarya M. Municipality has disclosed the list of vehicles to be procured in 2018. The Municipality's machinery park that owns 363 vehicles/machines currently will have 33 more with the financing through local sources.

According to **DETAY's** information, that the list of new procurements included in the 2018 Investment Program is as follows:

QTY	VEHICLE TYPE	DIFFERENTIAL	REQUIRED FOR DEPT. OF:
2	PICK-UP(Small truck, for offroad serv., 3 or 6 passen.cap.)	4x4	Yol Bakım Ve Altyapı Koordinasyon D. Başkanlığı
1	TRUCK(Chassis-cabin full load weight min. 3501 kg)		Yol Bakım Ve Altyapı Koordinasyon D. Başkanlığı
1	TRUC (Chassis-cabin full load weight min. 12.000 kg)		Yol Bakım Ve Altyapı Koordinasyon D. Başkanlığı
8	TRUCK (Chassis-cabin full load weight min. 17.000 kg)		Yol Bakım Ve Altyapı Koordinasyon D. Başkanlığı
1	PICK-UP (Small truck,for offroad serv., 6 passen.cap.)	4x2	Ulaşım Dairesi Başkanlığı
1	PANEL	4x2	Ulaşım Dairesi Başkanlığı
1	PR. CAR	4x2	İtfaiye Dairesi Başkanlığı
4	PICK-UP (Small truck, for offroad serv., 6 passen.cap.)	4x4	İtfaiye Dairesi Başkanlığı
1	MINİBÜS(Max.15 passen.cap. with driver.)	4x2	İtfaiye Dairesi Başkanlığı
4	TRUCK (Chassis-cabin full load weight min. 12.000 kg)	4x2	İtfaiye Dairesi Başkanlığı
2	TRUCK (Chassis-cabin full load weight min. 12.000 kg)		Çevre Koruma Ve Kontrol Dairesi Başkanlığı
1	PANEL	4x2	Strateji Geliştirme Dairesi Bşk.
2	PICK-UP(Small truck, 3 or 6 passen.cap. with driver)	4x2	Zabıta Dairesi Başkanlığı

LIST OF EXISTING VEHICLES

NO	VEHICLE TYPE	QTY
T1-(*)	Private car	
T2-	Private car	10
T3-	Station-Wagon	
T4-	Offroad car (Min. 4, max. 8 passen.cap.)	
T5-	Minibus (With driver,max. 15 passen.cap.)	15
T6-	Station Wag.(Offroad)	
T7-	Pick-up (Small Truck,, 3 or 6 passen.cap. with driver)	
T8-	Pick-up (Small Truck,for offroad serv., 3 or 6 passen.cap. with driver)	31
T9-	Panel	
T10-	Midibus (With driver,max. 26 passen.cap.)	15
T11-	Bus (With drivermin. 27 passen.cap.)	75
T12-	Truck, chassis-cabin full load weight min. 3501 kg	13
T13-	Truck, chassis-cabin full load weight min. 12.000 kg	12
T14-	Truck, chassis-cabin full load weight min. 17.000 kg	110
T15-	Ambulance (With medical equipment)	4
T16-	Ambulance for offroad serv.	
T17-	Pick-up (Small Truck) to be modified into hearse	
T18-	Motorbikes, min. 45-250 cc.	
T19-	Motorbikes min. 600 cc.	
T21-a	Security type Private car	
T21-b	Security type service car	
T22	Other vehicles	78

BURSA M.MUNICIPALITY'S 2018 VEHICLE PROCUREMENT LIST DISCLOSED

The Bursa M.Municipality has disclosed its 2018 Vehicle Procurement List, compiled from the "2018 Budget Program".

The Municipality's 2018 Fiscal Year Budget has been drafted as 2.650.000.000 TL (expenditures) and 2.600.000.000 TL (revenues).

The difference of 50.000.000 TL has been indicated in the economic classifying table.

According to **DETAY's** information, vehicle procurements will be made as per Transport Law no 237, for the following municipal departments:

- **T-7 4X2 double cabin small truck (With driver, 3 or 6 –passenger capacity)**
2 ea for Zabıta Şube Müdürlüğü (Control)
2 ea for Zabıta Müdürlüğü (Administrative)
2 ea for Yol İşleri Şube Müdürlüğü
- **T-8 4x4 Pick-Up (offroad services. With driver, 3 or 6 –passenger capacity)**
1 ea for Sahil Hizmetleri Şube Müdürlüğü
1 ea for Zabıta Müdürlüğü (Control)

1 ea for Zabıta Müdürlüğü (Administrative)

5 ea for Yol İşleri Şube Müdürlüğü

- **T-12 4x2 Truck;Chassis– cabin full weight min. 3.101 kğ.**
1 ea for Trafik Şube Müdürlüğü
- **T-13 4x2 Truck;Chassis– cabin full weight min. 12.000 kğ**
1 ea for Trafik Şube Müdürlüğü
- **T-14 Truck;Chassis – cabin full weight min. 17.000 kğ (Dumper)**
2 ea for 4x2 Parklar ve Bahçeler Şube Müd.
12 ea for 6x4 Yol İşleri Şube Müdürlüğü
- **T-15 Ambulance (with medical equipment)**
1 ea for 4x2 Sağlık İşleri Şube Müdürlüğü
- **T-17 Pick-Up (to be modified as funeral vehicle)**
1 ea for 4x2 Mezarlık İşleri Şube Müdürlüğü
- **T-19 Motorbike (min. 601 cc.)**
15 ea for Zabıta Dairesi Başkanlığı
- **T-22 ATV**
2 ea for Makine İşletme Şb. Müdürlüğü

ESKİŞEHİR METROPOLİTAN MUNICIPALITY'S BUDGET

The Eskişehir Metropolitan Municipality Assembly convened and gave final decisions on 6 subjects.

A total budget of 293 million TL 307.000 TL was allocated to the 2018 Investment Program .

According to the investment program debated at the Assembly, the biggest share has been obtained by the Transportation Department with 100 million TL for the tramway construction work in 2018.

The following amounts have been allocated to the other investment areas:

"30 million TL for rural and urban roads, 21 million TL for implementation and preservation of historical and cultural heritage, 36 million TL for expropriation services,

9 million TL for construction and operation of Solar Power Plants., 30 million TL for bus procurements, 2 million TL for Beylikova Mobile or Modular Rural Slaughterhouse

Construction, 44.012.000 TL for machinery, equipment, vehicle, spare parts and equipment procurements and building maintenance repairs renovation works."

Also an official letter will be written for procurement of 40 ea buses, during the Assembly meeting held on 9 October 2017.

The 2018 Fiscal Year Budget was ratified at the Assembly.

İSTANBUL-İSKİ GENERAL DIRECTORATE'S 2018 INVESTMENT PROGRAM

Istanbul M.Municipality's Water and Sewerage Administration (İSKİ) has published its "2018 Investment Program" on its website.

DETAY has compiled the following information regarding the projects to be realized and allocations awarded for the new year.

A SUMMARY OF 2018 INVESTMENT PROPOSALS

İSKİ GENERAL DIRECTORATE

AT 2018 PRICES (000 TL)

SECTOR D.K.H. SOCIAL INFRASTRUCTURE (DRINKINGWATER -SEWERAGE)	PROJECT COST	2018 INVESTMENT PROPOSAL			%
		ONGOING PROJECTS	NEW PROJECTS	TOTAL	
EUROPEAN SIDE DRINKINGWATER PROJECT	1.786.915	306.993	68.500	375.493	12,6
ANATOLIAN SIDE DRINKINGWATER PROJECT	1.952.943	386.956	16.700	403.656	13,5
EUROPEAN SIDE SEWERAGE PROJECT	3.970.237	607.991	220.751	828.742	27,8
ANATOLIAN SIDE SEWERAGE PROJECT	3.221.056	323.995	237.400	561.395	18,8
SURVEY PROJECT SERVICES	186.763	35.513	41.590	77.103	2,6
EXPROPRIATIONAL SERVICES	13.541.936	296.572	103.428	400.000	13,4
OTHER MACHINERY EQUIPMENT PROCUREMENTS	664.850	169.700	169.350	339.050	11,4
TOTAL	25.324.700	2.127.720	857.719	2.985.439	100

EUROPEAN SIDE DRINKINGWATER PROJECT (New Projects)

AT 2018 UNIT PRICES (000 TL)

INVESTING DEPARTMENT	PROJECT NAME	Financial source	Place (Prov.-Districts)	2018 INVESTMENT			2019 INVESTMENT		2020 INVESTM.	
				Frgn Source	Loc. Source	TOTAL	Frgn	TOTAL Frgn+Loc	Frgn	TOTAL Frgn +Loc
Su İnşaat Dai. Bşk.	European side various drinkingwater constr.(6)	İSKİ	Europ. Reg.		500	500		2500		2.000
Su İnşaat Dai. Bşk.	European side various drinkingwater constr.(7)	İSKİ	Europ. Reg.		500	500		2500		2.000
Su İnşaat Dai. Bşk.	European side various drinkingwater constr.(8)	İSKİ	Europ. Reg.		500	500		2500		2.000
Su İnşaat Dai. Bşk.	European side various drinkingwater constr.(9)	İSKİ	Europ. Reg.		500	500		2500		2.000
Su İnşaat Dai. Bşk.	European side various drinkingwater constr.(10)	İSKİ	Europ. Reg.		500	500		2500		2.000
Su İnşaat Dai. Bşk.	European side İSKİ Service facilities(1)	İSKİ	Europ. Reg.		500	500		3000		1500
Su İnşaat Dai. Bşk.	European side İSKİ Service facilities(2)	İSKİ	Europ. Reg.		500	500		3000		1500
Su İnşaat Dai. Bşk.	European side İSKİ Service facilities(3)	İSKİ	Europ. Reg.		500	500		3000		1500
Su İnşaat Dai. Bşk.	Yıldız Streams Rehabilit.Constr.	İSKİ	Europ. Reg.		5.000	5.000		10.000		10.000
Su İnşaat Dai. Bşk.	Yıldız Streams Water main Constr.	İSKİ	Europ. Reg.		1.000	1.000		5.000		4.000
Su İnşaat Dai. Bşk.	Terkos İkitelli Water main Constr.	İSKİ	City general		2.000	2.000		4.500		4.500
Su İnşaat Dai. Bşk.	Consultancy Serv.	İSKİ	Europ. Reg.		500	500		500		
Su İnşaat Dai. Bşk.	Aykome Investments (İBB)	İSKİ	City general		1.000	1.000		1.000		1.000
Su İnşaat Dai. Bşk.	European side Water main Constr.	İSKİ	Europ. Reg.		2.000	2.000		4.000		4.000
Su İnşaat Dai. Bşk.	Terkos-Büyükcemece Water main and Tunnel	İSKİ	Europ. Reg.		500	500		2.500		2.000
Su İnşaat Dai. Bşk.	Europ. Reg. İSKİ Buildings Maintenance and repair	İSKİ	Europ. Reg.		2.000	2.000		3.000		1.000
Su İnşaat Dai. Bşk.	Europ. Reg İSKİ facilities and lands security Buildings constr. for protection	İSKİ	Europ. Reg.		500	500		1.500		1.000

INVESTING DEPARTMENT	PROJECT NAME	Financial source	Place (Prov.- Districts)	2018 INVESTMENT			2019 INVESTMENT		2020 INVESTM.	
				Frgn Source	Loc. Source	TOTAL	Frgn	TOTAL Frgn+Loc	Frgn	TOTAL Frgn +Loc
Su İnşaat Dai. Bşk	İSKİ's Bebek lodgings maintenance	İSKİ	Europ. Reg.		1.000	1.000				
Su İnşaat Dai. Bşk	Water reservoirs Maintenance, clean. and repair works (IV)	İSKİ	Europ. Reg.		1.500	1.500		1.000		500
Su İnşaat Dai. Bşk	Water mains renewal. and Rehabil.it.without excavat. (I)	İSKİ	City general		1.500	1.500		1.500		
Su İnşaat Dai. Bşk	Water mains Water reservoirs operat.and Maintenance services(III)	İSKİ	City general		1.500	1.500		1.000		500
Su İsale ve Dağ. Dai. Bşk.	SCADA Centre and Outer Stations Operat. And Maintenance	İSKİ	City general		1.500	1.500		3.000		1.500
Su İnşaat Dai. Bşk	Europ. Reg.Header Centres Maintenance, revision services (I)	İSKİ	Europ. Reg.		1.500	1.500		3.000		500
Su İsale ve Dağ. Dai. Bşk.	Terkos and Istranca Reg. Header Centres and water mains Maintenance, revision services	İSKİ	Europ. Reg.		1.500	1.500		3.000		500
Avrupa İsale Dai. Bşk	Various electrical works (14)	İSKİ	Europ. Reg		3.000	3.000		27.000		
Avrupa İsale Dai. Bşk	Renewable energy resources utility(GES) 3	İSKİ	City general		3.000	3.000		14.000		13.000
Avrupa İsale Dai. Bşk	Renewable energy resources utility(GES) 4	İSKİ	City general		3000	3000		14.000		13.000
Avrupa İsale Dai. Bşk	Renewable energy resources utility(RES) 1	İSKİ	City general		5.000	5.000		15.000		30.000
Avrupa İsale Dai. Bşk	Renewable energy resources utility(RES) 2	İSKİ	City general		5.000	5.000		15000		30.000
Su Arıtma Dai. Bşk.	İstanbul drinkingwater treatment plants Maintenance services (2)	İSKİ	City general		20.000	20.000		20.000		20.000
Su Arıtma Dai. Bşk	İstanbul drinkingwater treatment plants Maintenance services (3)	İSKİ	City general		1.000	1.000		1.000		
	TOTAL				68.500	68.500		172.000		151.500

ANATOLIAN SIDE DRINKINGWATER PROJECT (New Projects)

AT 2018 UNIT PRICES (000 TL)

INVESTING DEPARTMENT	PROJECT NAME	Financial source	Place (Prov.- Districts)	2018 INVESTMENT			2019 INVESTMENT		2020 INVESTME.	
				Frgn. Source	Loc. Source	TOTAL	Frgn	TOTAL Frgn+Loc	Frgn	TOTAL Frgn+ Loc
Su İnşaat Dai. Bşk.	Asian side tunnel Constr. (I)	İSKİ	Anatol. side		3.000	3.000		17.000		10.000
Su İnşaat Dai. Bşk.	Asian side 8.Stage Miscellan.Drinkingwater Constr.	İSKİ	Anatol. side		500	500		2.500		2.000
Su İnşaat Dai. Bşk.	Asian side 9.Stage Miscellan. Drinkingwater Constr.	İSKİ	Anatol. side		500	500		2.500		2.000
Su İnşaat Dai. Bşk.	Küçükçamlıca Depot Constr.	İSKİ	Anatol. side		2.000	2.000		6.000		7.000
Su İnşaat Dai. Bşk.	Consultancy Serv.	İSKİ	Anatol. side		1.000	1.000				
Su İnşaat Dai. Bşk.	Çamlıca-Salacak Concrete pipe Rehabil.it. Constr.	İSKİ	Anatol. side		3.000	3.000		17.000		10.000
Su İnşaat Dai. Bşk	Asphalt coating (4)	İSKİ	City general		5.000	5.000		10.000		15.000
Hizmet Dest. Dai.Bşk	Anatolian Side İSKİ Buildings Miscellan. Maintenance repair (VIII)	İSKİ	Anatol. side		1.000	1.000		2.500		1.500
Hizmet Dest. Dai.Bşk	Anatolian Side İSKİ Facilities and lands surrounding walls and security Buildings for protection	İSKİ	Anatol. side		500	500		1.500		1000

INVESTING DEPARTMENT	PROJECT NAME	Financial source	Place (Prov.- Districts)	2018 INVESTMENT			2019 INVESTMENT		2020 INVESTME.	
				Frgn. Source	Loc. Source	TOTAL	Frgn	TOTAL Frgn+Loc	Frgn	TOTAL Frgn+ Loc
Hizmet Dest. Dai.Bşk	İSKİ İsaköy Header centre roof constr.	İSKİ	Anatol. side		200	200		1.300		
Su İnşaat Dai. Bşk.	Asian side Tunnel Constr. (I)	İSKİ	Anatol. side		3.000	3.000		17.000		10.000
Su İnşaat Dai. Bşk.	Asian side 8.Stage Miscellan.Drinkingwater Constr.	İSKİ	Anatol. side		500	500		2.500		2.000
Su İnşaat Dai. Bşk	Asian side 9.Stage Miscellan.Drinkingwater Constr.	İSKİ	Anatol. side		500	500		2.500		2.000
Su İnşaat Dai. Bşk	Küçükçamlıca Depot Constr.	İSKİ	Anatol. side		2.000	2.000		6.000		7.000
Su İnşaat Dai. Bşk	Consultancy Serv.	İSKİ	Anatol. side		1.000	1.000				
Su İnşaat Dai. Bşk	Çamlıca-Salacak Concrete pipe Rehabilitt. Constr.	İSKİ	Anatol. side		3.000	3.000		17.000		10.000
Su İnşaat Dai. Bşk	Asphalt coating (4)	İSKİ	City general		5.000	5.000		10.000		15.000
Dest.Hiz.Dai.Bşk.	Anatolian Side İSKİ Buildings Maintenance and repair (VIII)	İSKİ	Anatol. side		1.000	1.000		2.500		1.500
Dest.Hiz.Dai.Bşk.	Anatolian Side İSKİ Facilities and lands surrounding walls and security Buildings for protection	İSKİ	Anatol. side			500	500	1.500		1.000
Dest.Hiz.Dai.Bşk.	İSKİ İsaköy Header centre roof constr. and ground injection	İSKİ	Anatol. side			200	200	1.300		
	TOTAL				16.700	16.700		60.300		48.500

EUROPEAN SIDE SEWERAGE PROJECT (New Projects)

AT 2018 UNIT PRICES (000 TL)

INVESTING DEPARTMENT	PROJECT NAME	Financial source	Place (Prov.- Districts)	2018 INVESTMENT			2019 INVESTMENT		2020 INVESTM.	
				Frgn. Source	Loc. Source	TOTAL	Frgn	TOTAL Frgn+Loc	Frgn	TOTAL Frgn+ Loc
Atıksu İnş. Dai. Bşk.	Euro.Reg.1., 1.Stage Tunnel Constr.	İSKİ	Euro.Reg. 1		2.800	2.800		8.000		8.000
Atıksu İnş. Dai. Bşk.	Euro.Reg.1., 5.Stage Miscellan.wastewater stormwater channel and stream rehab. Constr.	İSKİ	Euro.Reg. 1		2.000	2.000		6.000		6.000
Atıksu İnş. Dai. Bşk.	Euro.Reg.1., 2.Stage Tunnel Constr.	İSKİ	Euro.Reg 2		2.800	2.000		6.000		6.000
Atıksu İnş. Dai. Bşk.	Euro.Reg.1. 2015 1.Stage Miscellan. wastewater stormwater channel and stream rehab. Constr	İSKİ	Euro.Reg.1		2.000	2.000		8.000		8.000
Atıksu İnş. Dai. Bşk.	Euro.Reg.2., 1.Stage Tunnel Constr.	İSKİ	Euro.Reg.2		2.000	2.000		6.000		6.000
Atıksu İnş. Dai. Bşk.	Euro.Reg.2., 2.Stage Tunnel Constr.	İSKİ	Euro.Reg.2		2.000	2.000		6.000		6.000
Atıksu İnş. Dai. Bşk.	Euro.Reg.2., 3.Stage Miscellan. wastewater stormwater channel and pipe jacking	İSKİ	Euro.Reg.2		2.000	2.000		4.000		6.000
Atıksu İnş. Dai. Bşk.	Euro.Reg.2., 4.Stage Miscellan. wastewater stormwater channel and stream rehab. Constr	İSKİ	Euro.Reg.2		2.000	2.000		4.000		6.000
Atıksu İnş. Dai. Bşk.	Euro.Reg.2., 5.Stage Miscellan. wastewater stormwater channel and stream rehab. Constr	İSKİ	Euro.Reg.2		2.000	2.000		6.000		6.000
Atıksu İnş. Dai. Bşk.	Euro.Reg.2., 6.Stage Miscellan. wastewater stormwater channel and stream rehab. Constr	İSKİ	Euro.Reg.2		2.000	2.000		6.000		6.000
Atıksu İnş. Dai. Bşk.	Euro.Reg.2., 7.Stage Miscellan. wastewater stormwater channel and stream rehab. Constr	İSKİ	Euro.Reg.2		2.000	2.000		6.000		6.000
Atıksu İnş. Dai. Bşk.	Euro.Reg. Consultancy Serv.	İSKİ	Euro.Reg.2		100	100		400		400
Atıksu İnş. Dai. Bşk.	Gümüşdere biol.wastewater treatment plant Constr.	İSKİ	Kilyos		2.000	2.000		2.000		8.000
Atıksu İnş. Dai. Bşk.	Silahtarağa advanced biol.wastewater treatment plan Constr.	İSKİ	Eyüp		50.000	50.000		110.000		120.000

INVESTING DEPARTMENT	PROJECT NAME	Financial source	Place (Prov.- Districts)	2018 INVESTMENT			2019 INVESTMENT		2020 INVESTM.	
				Frgn. Source	Loc. Source	TOTAL	Frgn	TOTAL Frgn+Loc	Frgn	TOTAL Frgn+ Loc
Atıksu İnş. Dai. Bşk.	Euro.Reg. Final Account Difference	İSKİ	City general		4.000	4.000		4.000		4.000
Atıksu İnş. Dai. Bşk.	Wastewater treatment plan Annex Unit. Constr. (2)	İSKİ	Euro.Reg.1		1.000	1.000		4.000		4.000
Atıksu İnş. Dai. Bşk.	Başakşehir advanced biol. Wastewater treatment plan	İSKİ	Euro.Reg		2.000	2.000		8.000		8.000
Atıksu İnş. Dai. Bşk.	Ambarlı advanced biol.Wastewater treatment plan II.Stage Constr.	İSKİ	Euro.Reg.2		2.000	2.000		8.000		8.000
Atıksu İnş. Dai. Bşk.	Yenikapı biol. treatment Constr.	İSKİ	Yenikapı		40.000	40.000		50.000		100.000
Atıksu İnş. Dai. Bşk.	Esenler Stormwater Postponem. Pond Constr.	İSKİ	Esenler		500	500		2.000		2.000
Abone İşl.Avr.1.Böl. Dai Bşk.	2018 Abone İşleri: Eur.Region Miscellan. Drinkingwater and Wastewater lines Build. maintenance servc.(2)	İSKİ	Euro.Reg.1		1.667	1.667		7.500		5.833
Abone İşl.Avr.1.Böl. Dai Bşk.	2018 Final Account Difference at Dept.Direct.	İSKİ	Euro.Reg.1		412	412				
Abone İşl.Avr.1.Böl. Dai Bşk.	2018 Abone İşleri: Euro.Reg.1. Drinkingwater and Wastewater Building maintenance services.(4)	İSKİ	Euro.Reg.1		9.188	9.188		24.500		24.500
Abone İşl.Avr.1.Böl. Dai Bşk.	2018 Abone İşleri: Euro.Reg. Miscellan. Drinkingwater and Wastewater lines Build. maintenance servc.(1)	İSKİ	Euro.Reg.1		1.500	1.500		7.500		6.000
Abone İşl.Avr.1.Böl. Dai Bşk.	Final Account Difference at Dept.Direct.	İSKİ	Euro.Reg.1		384	384				
Abone İşl. Avr. 2.Böl. Dai. Bşk.	Final Account Difference at Dept.Direct.	İSKİ	Euro.Reg.2		500	500				
Abone İşl. Avr. 2.Böl. Dai. Bşk.	2018 Av. Böl..2.Bölge Abone İşleri Daire Başkanlığı: Drinkingwater and Wastewater Build. maintenance servc.(2)	İSKİ	Euro.Reg.2		15.300	15.300		19.800		19.800
Abone İşl. Avr. 2.Böl. Dai. Bşk.	2018 Av. Böl..2.Bölge Abone İşleri Daire Başkanlığı: Drinkingwater and Wastewater Build. maintenance servc.(4)	İSKİ	Euro.Reg.2		6.000	6.000		19.800		19.800
Abone İşl. Avr. 2.Böl. Dai. Bşk.	2018 Av. Böl..2.Bölge Abone İşleri Daire Başkanlığı: Drinkingwater and Wastewater Build. maintenance servc.(1)	İSKİ	Euro.Reg.2		6.000	6.000		14.000		
Abone İşl. Avr. 2.Böl. Dai. Bşk.	2018 Av.Böl.2.Bölge Abone İşleri Daire Başkanlığı: Drinkingwater and Wastewater Build. maintenance servc (2)	İSKİ	Euro.Reg.2		6.000	6.000		14.000		
Atıksu Arıtma Dai. Bşk.	Wastewater Treatment Facilities smell disposal Systems constr. (4)	İSKİ	Anatol.Reg.		1.000	1.000		1.000		500
Atıksu Arıtma Dai. Bşk.	Wastewater Treatment Facilities smell disposal Systems constr (3)	İSKİ	Anatol.Reg.		1.000	1.000		1.000		500
Atıksu Arıtma Dai. Bşk.	Package Wastewater treatment plant (2)	İSKİ	City general		5.000	5.000		2.000		1.000
Atıksu Arıtma Dai. Bşk.	Wastewater Treatment Facilities recycling Systems constr.(2)	İSKİ	City general		3.000	3.000		500		500
Atıksu Arıtma Dai. Bşk.	Paket Wastewater treatment plant procur.(1)	İSKİ	City general		6.000	6.000		2.000		2.000
Atıksu Arıtma Dai. Bşk.	Wastewater Treatment Facilities disinfection systems constr. (2)	İSKİ	City general		4.000	4.000		2.000		1.000
Atıksu Arıtma Dai. Bşk.	Wastewater Treatment Facilities Renewal, Develop.,and Equip.Procurem.(1)	İSKİ	City general		5.000	5.000		4.000		2.000
Atıksu Arıtma Dai. Bşk.	Wastewater Treatment Facilities Renewal, Develop.,and Equip.Procurem.(2)	İSKİ	City general		5.000	5.000		3.000		2.000
Atıksu Arıtma Dai.	Wastewater Treatment Facilities Renewal,	İSKİ	City general		3.000	3.000		1.000		1.000

INVESTING DEPARTMENT	PROJECT NAME	Financial source	Place (Prov.- Districts)	2018 INVESTMENT			2019 INVESTMENT		2020 INVESTMENT	
				Frgn. Source	Loc. Source	TOTAL	Frgn	TOTAL Frgn+Loc	Frgn	TOTAL Frgn+Loc
Bşk.	Develop.,and Equip.Procurem.(3)									
Atıksu Arıtma Dai. Bşk.	Wastewater Treatment Facilities SCADA Renewal, Develop.,and Equip.Procurem.(2)	İSKİ	City general		2.000	2.000		2.000		1.000
Atıksu Arıtma Dai. Bşk.	Wastewater Treatment Facilities disinfection systems constr (1)	İSKİ	City general		7.000	7.000		2.000		1.000
Kanalizasyon Dai. Bşk.	European side 3.Stage Miscellan. Wastewater stormwater, stream cleaning, maintenance Constr.	İSKİ	Euro.Reg		1.500	1.500		6.750		6.750
Kanalizasyon Dai. Bşk.	European side 6.Stage Miscellan. Wastewater stormwater, stream cleaning, maintenance Constr..	İSKİ	Euro.Reg		1.500	1.500		6.750		6.750
Kanalizasyon Dai. Bşk.	European side 7.Stage Miscellan. Wastewater stormwater, stream cleaning, maintenance Constr..	İSKİ	Euro.Reg		1.500	1.500		6.750		6.750
Kanalizasyon Dai. Bşk.	City general wastewater collectors Rehabilit.Constr. without excavat. (1)	İSKİ	Euro.Reg		700	700		6.300		
Kanalizasyon Dai. Bşk.	City general wastewater collectors Rehabilit.Constr. without excavat. (2)	İSKİ	Euro.Reg		700	700		6.300		
Kanalizasyon Dai. Bşk.	City general wastewater stormwater lines monitoring	İSKİ	Euro.Reg		700	700		6.300		
	TOTAL				220.751	220.751		421.150		433.083

ANATOLIAN SIDE SEWERAGE PROJECT (New Projects)

AT 2018 UNIT PRICES (000 TL)

INVESTING DEPARTMENT	PROJECT NAME	Financial source	Place (Prov.- Districts)	2018 INVESTMENT			2019 INVESTMENT		2020 INVESTMENT	
				Frgn. Source	Loc. Source	TOTAL	Dış	TOTAL Frgn+Loc	Frgn	TOTAL Frgn+Loc
Atıksu İnş. Dai. Bşk.	Asian side 3.Stage Miscellan.Wastewater, storm water channels , Uzundere transfer tunnel Constr.	İSKİ	Anatol.Reg.		2.000	2000		8.000		8.000
Atıksu İnş. Dai. Bşk.	Asian side 6.Stage Miscellan. Wastewater,Storm water and stream rehab. Constr.	İSKİ	Anatol.Reg.		2.000	2.000		8.000		8.000
Atıksu İnş. Dai. Bşk.	Asian side 7.Stage Miscellan. Wastewater,Storm water and stream rehab. Constr.	İSKİ	Anatol.Reg.		2.000	2.000		8.000		8.000
Atıksu İnş. Dai. Bşk.	Asian side 8.Stage Miscellan. Wastewater,Storm water and stream rehab. Constr.	İSKİ	Anatol.Reg.		2.000	2.000		8.000		8.000
Atıksu İnş. Dai. Bşk.	Asian side 9.Stage Miscellan. Wastewater, Storm water and stream rehab. Constr.	İSKİ	Anatol.Reg.		2.000	2.000		8.000		8.000
Atıksu İnş. Dai. Bşk.	Asian side 10.Stage Miscellan. Wastewater,Storm water and stream rehab. Constr.	İSKİ	Anatol.Reg.		2.000	2.000		8.000		8.000
Atıksu İnş. Dai. Bşk.	Asian side 11.Stage Miscellan. Wastewater,Storm water and stream rehab. Constr.	İSKİ	Anatol.Reg.		2.000	2.000		8.000		8.000
Atıksu İnş. Dai. Bşk.	Biolog. Wastewater Treatment Facilities Constr. (2)	İSKİ	City general		500	500		2.000		2.000

INVESTING DEPARTMENT	PROJECT NAME	Financial source	Place (Prov.- Districts)	2018 INVESTMENT			2019 INVESTMENT		2020 INVESTMENT	
				Frgn. Source	Loc. Source	TOTAL	Dış	TOTAL Frgn+Loc	Frgn	TOTAL Frgn+Loc
Atıksu İnş. Dai. Bşk	Biolog. Wastewater Treatment Facilities Constr. (3)	İSKİ	City general		500	500		2.000		2.000
Atıksu İnş. Dai. Bşk	Asian side Consultancy services	İSKİ	City general		100	100		400		400
Atıksu İnş. Dai. Bşk	Kadıköy Sea outfall II.Stage Constr.	İSKİ	Anatolia.R.		5.000	5.000		15.000		15.000
Atıksu İnş. Dai. Bşk	Under Melen Basin Environ.Protect.Prj. Miscellan.Wastewater Treatment Facilities Channel Constr.	İSKİ	Düzce-Melen		15.000	15.000		40.000		40.000
Atıksu İnş. Dai. Bşk	Şile Advan. Biolog. Wastewater treatment plan Constr.	İSKİ	Şile		2.000	2.000		2.000		8.000
Atıksu İnş. Dai. Bşk	Kadıköy Biolog. Wastewater treatment plan Constr.	İSKİ	Kadıköy		50.000	50.000		100.000		130.000
Atıksu İnş. Dai. Bşk	Paşaköy III. Stage Advanced Biolog. Wastewater treatment plan Constr.	İSKİ	Paşaköy		40.000	40.000		40.000		80.000
Atıksu İnş. Dai. Bşk	Asian side Final Account Difference	İSKİ	Anatol.Reg.		4.000	4.000		4.000		4.000
Atıksu İnş. Dai. Bşk	Artma Tesisleri İnşaat Müdürlüğü: Consultancy Serv.	İSKİ	Anatol.Reg.		100	100		400		400
Atıksu İnş. Dai. Bşk	Düzce Wastewater tunnel Constr.	İSKİ	Düzce		5.000	5.000		15.000		15.000
Abone İşl.Asya Böl. Dai. Bşk.	2018 Asya Böl. Abone İşleri Dairesi Başkanlığı: Drinkingwater and wastewater constr. , Maintenance and repair (3)	İSKİ	Pendik Kartal Maltepe Tuzla		7.500	7.500		25.000		25.000
Abone İşl.Asya Böl. Dai. Bşk.	2018 Asya Böl. Abone İşleri Dairesi Başkanlığı: Drinkingwater and wastewater constr. , Maintenance and repair (1)	İSKİ	Anatol.Reg.		2.000	2.000		6.750		6.750
Abone İşl.Asya Böl. Dai. Bşk.	Final Account Difference at Dept.Direct.	İSKİ	Anatol.Reg.		500	500				
Kanalizasyon Dai. Bşk.	Asian side 3.Stage Miscellan. wastewater, Storm water, stream, Clean.mainten. repair works	İSKİ	Anatol.Reg.		1.800	1.800		8.100		8.100
Kanalizasyon Dai. Bşk.	Asian side 4.Stage Miscellan. wastewater, Storm water, stream, Clean.mainten. repair works	İSKİ	Anatol.Reg.		1.900	1.900		8.550		8.550
Atıksu Arıtma Dai. Bşk.	Paket Wastewater treatment plan procur. (3)	İSKİ	City general		5.000	5.000		2.000		1.000
Atıksu Arıtma Dai. Bşk.	wastewater treatment facilities SCADA Renewal, Develop.,and Equip.Procurem.(1)	İSKİ	City general		2.000	2.000		1.000		1.000
Atıksu Arıtma Dai. Bşk.	wastewater treatment facilities disinfection systems install. (3)	İSKİ	City general		3.000	3.000		2.000		1.000
Atıksu Arıtma Dai. Bşk.	wastewater treatment facilities recycling sys.install. (1)	İSKİ	City general		3.000	3.000		3.000		1.000
Atıksu Arıtma Dai. Bşk.	Tuzla Wastewater treatment plan sludge incineration sys.	İSKİ	Anatol.Reg.		72.000	72.000		90.000		50.000
Atıksu Arıtma Dai. Bşk.	Wastewater Treatment Facilities smell disposal systems install. (1)	İSKİ	Anatol.Reg.		1.500	1.500		2.000		500
Atıksu Arıtma Dai. Bşk.	Wastewater Treatment Facilities smell disposal systems install. (2)	İSKİ	Anatol.Reg.		1.000	1.000		1.000		500
	TOTAL				237.400	237.400		426.200		456.200

EUROPEAN SIDE DRINKINGWATER PROJECT (New Survey Project Services)

AT 2018 UNIT PRICES (000 TL)

INVESTING DEPARTMENT	PROJECT NAME	Financial source	Place (Prov.- Districts)	2018 INVESTMENT			2019 INVESTMENT		2020 INVESTMENT	
				Frgn. Source	Loc. Source	TOTAL	Frgn	TOTAL Frgn+Loc	Frgn	TOTAL Frgn+Loc
Plan Proje ve Yatırım Dai. Bşk.	Spring areas fixat. project (1)	İSKİ	City general		50	50		100		50
Plan Proje ve Yatırım Dai. Bşk.	Spring areas fixat. project (2)	İSKİ	City general		50	50		100		50
Plan Proje ve Yatırım Dai. Bşk.	Water museum service proc. (1)	İSKİ	City general		1.000	1.000				
Plan Proje ve Yatırım Dai. Bşk.	Various areas maintenance serv. (2)	İSKİ	City general		500	500		250		250
Plan Proje ve Yatırım Dai. Bşk.	Paper masterpieces restoration (1)	İSKİ	City general		50	50		100		50
Plan Proje ve Yatırım Dai. Bşk.	Historical map/notebook translation and public.(1)	İSKİ	City general		100	100		200		
Plan Proje ve Yatırım Dai. Bşk.	Fountains Repair Prj. (2)	İSKİ	City general		50	50		150		
Plan Proje ve Yatırım Dai. Bşk.	Fountains Repair Prj. (3)	İSKİ	City general		50	50		150		
Plan Proje ve Yatırım Dai. Bşk.	Fountains Restoration (2)	İSKİ	City general		50	50		150		
Plan Proje ve Yatırım Dai. Bşk.	Water weirs repair project(2)	İSKİ	City general		350	350		350		
Plan Proje ve Yatırım Dai. Bşk.	Water weirs repair project(3)	İSKİ	City general		100	100		200		
Plan Proje ve Yatırım Dai. Bşk.	Water weirs repair project(4)	İSKİ	City general		100	100		200		
Plan Proje ve Yatırım Dai. Bşk.	Aqueducts repair project(4)	İSKİ	City general		30	30		70		
Plan Proje ve Yatırım Dai. Bşk.	Aqueducts repair project (1)	İSKİ	City general		300	300		500		200
Plan Proje ve Yatırım Dai. Bşk.	Fountain design	İSKİ	City general		500	500				
Plan Proje ve Yatırım Dai. Bşk.	Fountain constr., Maintenance and repair (1)	İSKİ	City general		15.000	15.000		10.000		
Plan Proje ve Yatırım Dai. Bşk.	Water depots restoration (3)	İSKİ	City general		100	100		100		
Plan Proje ve Yatırım Dai. Bşk.	İstanbul city new fountains prj.	İSKİ	City general		200	200				
Plan Proje ve Yatırım Dai. Bşk.	Historical water ways underground and ground structures fixing project(1)	İSKİ	City general		200	200		500		300
Su İnşaat Dai. Bşk.	Drinkingwater network Rehabilit. project(3)	İSKİ	City general		100	100		100		300
Su İnşaat Dai. Bşk.	Drinkingwater network Rehabilit. project(4)	İSKİ	City general		100	100		100		300
Su İnşaat Dai. Bşk.	Drinkingwater network Rehabilit. project(5)	İSKİ	City general		100	100		100		300
Su İnşaat Dai. Bşk.	Drinkingwater network Rehabilit. project(6)	İSKİ	City general		100	100		100		300
Su İnşaat Dai. Bşk.	Drinkingwater network Rehabilit. project(7)	İSKİ	City general		100	100		100		300
Su İnşaat Dai. Bşk.	Water structures Project Services (1)	İSKİ	City general		100	100		100		100
Su İnşaat Dai. Bşk.	Water structures Project Services (2)	İSKİ	City general		100	100		100		100
Su İnşaat Dai. Bşk.	Water structures Project Services (3)	İSKİ	City general		100	100		100		100
Su İnşaat Dai. Bşk.	Water structures Project Services (4)	İSKİ	City general		100	100		100		100
Su İnşaat Dai. Bşk.	Water structures Project Services (5)	İSKİ	City general		100	100		100		100
Ar-Ge Dai. Bşk.	Research and Development Project of Mathematical Modeling of Drinking Water	İSKİ	City general		1.000	1.000		500		

INVESTING DEPARTMENT	PROJECT NAME	Financial source	Place (Prov.- Districts)	2018 INVESTMENT			2019 INVESTMENT		2020 INVESTMENT	
				Frgn. Source	Loc. Source	TOTAL	Frgn	TOTAL Frgn+Loc	Frgn	TOTAL Frgn+Loc
	Treatment Plant Projects									
Ar-Ge Dai. Başk.	Toxic Hazard Analyzer Development in Drinking Water	İSKİ	City general		1.500	1.500		750		750
Ar-Ge Dai. Başk.	Investigation of Effects of Evaporation Reduction Product, Produced by Using Domestic Technology, on Ecological life, Evaporation and Rehabilitation	İSKİ	City general		500	500				
Ar-Ge Dai. Başk.	Project on Evaluation of Global Climate Change Impact on İstanbul Water Resources and Infrastructure	İSKİ	City general		1.500	1.500		500		
Ar-Ge Dai. Başk.	Investigation of the effect of a possible earthquake on İstanbul water-Wastewater Facility and Network Lines	İSKİ	City general		3.500	3.500		1.500		
Ar-Ge Dai. Başk.	Pilot Study of Water leaks and Detection by Satellite Qualification	İSKİ	City general		1.000	1.000				
Ar-Ge Dai. Başk.	Drinking Water Management standardization Project	İSKİ	City general		500	500		500		
	TOTAL				29.280	29.280		17.870		3.650

ANATOLIAN SIDE DRINKINGWATER PROJECT (New Survey Project Services)

AT 2018 UNIT PRICES (000 TL)

INVESTING DEPARTMENT	PROJECT NAME	Financial source	Place (Prov.- Districts)	2018 INVESTMENT			2019 INVESTMENT		2020 INVESTMENT	
				Frgn. Source	Loc. Source	TOTAL	Frgn	TOTAL Frgn+Loc	Frgn	TOTAL Frgn+Loc
Plan Proje ve Yatırım Dai. Bşk.	Spring areas fixat. project (3)	İSKİ	City general		50	50		100		50
Plan Proje ve Yatırım Dai. Bşk.	Spring areas fixat. project (4)	İSKİ	City general		50	50		100		50
Plan Proje ve Yatırım Dai. Bşk.	Historical Water Plans Project and Repair Works Consultancy Serv. (1)	İSKİ	City general		50	50		200		150
Plan Proje ve Yatırım Dai. Bşk.	Water weirs repair project(5)	İSKİ	City general		200	200		500		
Plan Proje ve Yatırım Dai. Bşk.	Water weirs repair project(6)	İSKİ	City general		30	30		70		
Plan Proje ve Yatırım Dai. Bşk.	Water weirs repair project(7)	İSKİ	City general		30	30		70		
Plan Proje ve Yatırım Dai. Bşk.	Aqueducts repair project(3)	İSKİ	City general		100	100		200		
Plan Proje ve Yatırım Dai. Bşk.	Historical Water Depot Repair project (3)	İSKİ	City general		100	100		100		
Plan Proje ve Yatırım Dai. Bşk.	Water Depot restorations (2)	İSKİ	City general		100	100		100		
Plan Proje ve Yatırım Dai. Bşk.	Fountains Maintenance and repair (2)	İSKİ	City general		50	50		150		
Plan Proje ve Yatırım Dai. Bşk.	Demolition of the Remains of structures in the Historical Water Conservation Areas	İSKİ	City general		500	500		500		

INVESTING DEPARTMENT	PROJECT NAME	Financial source	Place (Prov.- Districts)	2018 INVESTMENT			2019 INVESTMENT		2020 INVESTMENT	
				Frgn. Source	Loc. Source	TOTAL	Frgn	TOTAL Frgn+Loc	Frgn	TOTAL Frgn+Loc
Plan Proje ve Yatırım Dai. Bşk.	İSKİ Boyacıköy Ancient Buildings Maintenance and Repair Application Work	İSKİ	City general		750	750		1.500		
Plan Proje ve Yatırım Dai. Bşk.	Historical Water Depot Repair project (2)	İSKİ	City general		100	100		400		
Plan Proje Dai. Bşk.	Drinking Water Treatment Plant project (2)	İSKİ	City general		300	300		400		
Plan Proje ve Yatırım Dai. Bşk.	Drinking water treatment project (3)	İSKİ	City general		300	300		400		
Plan Proje ve Yatırım Dai. Bşk.	Archive Research on Historical Water Constructions project(1)	İSKİ	City general		50	50		50		100
Plan Proje Dai. Bşk.	İSKİ Boyacıköy Ancient Building repair prj.	İSKİ	City general		250	250		250		
Emlak İstimlak Bşk.	Online Deformation metering serv	İSKİ	City general		1.500	1.500		1.000		500
Emlak İstimlak Bşk.	İSKİ Service Area Mapping Work (6)	İSKİ	City general		600	600		1.000		400
Emlak İstimlak Bşk.	Final Account difference	İSKİ	City general		100	100				
	TOTAL				5.210	5.210		7.090		1.500

EUROPEAN SIDE DRINKINGWATER PROJECT (New Survey Project Services)

AT 2018 UNIT PRICES (000 TL)

INVESTING DEPARTMENT	PROJECT NAME	Financial source	Place (Prov.- Districts)	2018 INVESTMENT			2019 INVESTMENT		2020 INVESTMENT	
				Frgn. Source	Loc. Source	TOTAL	Frgn	TOTAL Frgn+Loc	Frgn	TOTAL Frgn+Loc
Atıksu İnş. Dai. Bşk.	Yenikapi Wastewater Basin Sewerage Modeling	İSKİ	City general		200	200		400		200
Atıksu İnş. Dai. Bşk.	Creek Rehabilitation and Landscape Projecting(1)	İSKİ	City general		200	200		400		200
Atıksu İnş. Dai. Bşk.	Wastewater, Storm water Project serv. (1)	İSKİ	City general		200	200		400		200
Atıksu İnş. Dai. Bşk.	Wastewater, Storm water Project serv. (2)	İSKİ	City general		200	200		400		200
Atıksu İnş. Dai. Bşk.	Wastewater, Storm water Project serv. (3)	İSKİ	City general		200	200		400		200
Atıksu İnş. Dai. Bşk.	Wastewater, Storm water Project serv. (4)	İSKİ	City general		200	200		400		200
Atıksu İnş. Dai. Bşk.	Wastewater , Storm water tunnel Project serv. (1)	İSKİ	City general		200	200		400		200
Plan Proje Dai. Bşk.	Wastewater treatment plant feasibility works (2)	İSKİ	European		150	150		150		
Plan Proje Dai. Bşk.	Wastewater treatment plant Prj.(1)	İSKİ	European		300	300		400		
Plan Proje Dai. Bşk.	Wastewater treatment plant Prj. (2)	İSKİ	City general		300	300		400		100
Plan Proje Dai. Bşk.	Wastewater treatment plant feasibility works (1)	İSKİ	European		150	150		150		
Plan Proje Dai. Bşk.	Wastewater Treatment Facilities ÇED Rep. (Environ.İmpact Asses.)Report Preparation	İSKİ	City general		100	100		100		
Plan Proje Dai. Bşk.	Sludge incineration prjct and consultancy (1)	İSKİ	City general		100	100		400		250
Ar-Ge Dai. Bşk.	Wastewater main flows low cost aerobic active sludge (GAÇ) system lab scale establishment	İSKİ	City general		750	750		250		
Ar-Ge Dai. Bşk.	Investigation of the Usability of Domestic Wastewater Treatment Sludges in Land Improvement / Flower-Tree-Turf Growing Project	İSKİ	City general		500	500				
Ar-Ge Dai. Bşk.	Wastewater Management Standardisation Project	İSKİ	City general		1.450	1.450		500		
	TOTAL				5.200	5.200		5.150		1.750

LIST OF VEHICLES TO BE PROCURED BY STATE MANagements IN 2018 (T- TABLE)

Along with the debates ongoing on the 2018 Central Management Budget Law at the Parliament, the list of vehicles to be procured by general and special budget managements in 2018 according to Law no 5018 Annex Tables (I), (II) and (III) has been disclosed.

According to a **DETAY** survey, 4.526 units of transports vehicles and 50.000 ea bikes are planned to be procured by managements with general budgets and a total of 5.162 units of transports vehicles by

managements with special budgets in 2018. Last year, a total of 6.953 units of transports vehicles were procured by managements with general and special budgets (Of them 6179 units purchased by general budget managements and 774 units by special budget managements).

Below are the subject vehicle procurements (maximum purchasing costs) specified in Table-T for 2018:

T – TABLE (Maximum purchasing costs of the transport vehicles to be procured)

No	VEHICLE TYPE	Max. Purchasing Cost (TL)
1-a (*)	Private Car	151.200
1-b (**)	Private Car	166.350
2	Private Car	54.250
3	Station-Wagon	56.700
4	Offroad car (Min. 4, max. 8 passenger cap.)	96.750
5	Minibus (With driver max. 17 passenger cap.)	87.500
6	Station Car (Offroad services)	127.500
7	Pick-up (Small truck, with driver 3 or 6 passenger cap.)	77.700
8	Pick-up (Small truck, offroad services With driver 3 or 6 passenger cap.)	98.600
9	Panel	76.400
10	Midibus (With driver max. 26- passenger cap.)	167.850
11-a	Bus (With driver min. 27, max. 40 passenger cap.)	262.550
11-b	Bus (With driver max. 41 passenger cap.)	598.250
12	Truck, Chassis cabin full weight min.3.501 kg	98.550
13	Truck, Chassis cabin full weight min.12.000 kg	145.250
14	Truck, Chassis cabin full weight min.17.000 kg	176.500
15	Ambulance (With medical equipment)	177.550
16	Ambulance (Offroad services)	222.200
17	Pick-up (Small truck) (to be converted to hearse)	78.000
18	Motorbikes (Max.600 cc. cap.)	11.900
19	Motorbikes (Min.601 cc. cap.)	28.500
20	Bikes	2.650
21-a	Private Car with security system (Type and price to be determined by Ministry of Finance)	
21-b	Service Car with security system (Type and price to be determined by Ministry of Finance)	
22-	Other vehicles (Type and price to be determined by Ministry of Finance)	

(*) Vehicles to be purchased by Foreign Affairs Ministry and other offices listen in table (1) attached to Law no 237 for use in state protocol services.

(**) For the offices listed in the first 3 items of table (1) attached to Law no 237.

Note:

- 1) Maximum purchasing costs specified are before any tax payments. Finance Ministry is authorized to make any changes in the maximum costs and quantities shown in the list.
- 2) Armoured vehicles to be purchased for Security General Directorate are not included in this table.
- 3) Finance Ministry is authorized to make any changes in the maximum costs and quantities shown in the list, based on the view from Ministry of Development
- 4) Types and prices of vehicles to be procured by the Office of Presidency, TGNA and Prime Ministry are determined by the their Higher Administrators.
- 5) According to article 10, para 9 of Law no 237 the number of vehicles to be procured by exchange cannot exceed 50 units for National Defense Ministry, 10 units for Gendarmerie General Command and 5 units for Coast Guard Command.
- 6) The vehicles which are not economical to be procured by administrations in scope of central management through service procurement can be purchased, after a Council of Ministers decision based on proposal by Finance Ministry, with the type and quantity to be demanded by the relevant administration, to be met together with *the 100 ea T-22 other vehicles*, placed among the vehicles to be procured by Finance Ministry as specified in (T) Table, with the costs to be paid for from the relevant administration's budget with reference to the investment program as per regulations set in the decision on the Implementation, Coordination and Monitoring of the 2018 Program

VEHICLES TO BE PROCURED BY GENERAL BUDGET MANAGERMENTS IN 2018

MANAGEMENT	T TABLE	VEHICLE TYPE	QTY/ea
OFFICE OF PRESIDENCY	T01b	Private Car	5
	T02	Private Car	9
	T05	Minibus (With driver max. 17 passenger cap.)	4
	T09	Panel	2
	T11a	Bus (With driver min 27, max. 40- passenger cap.)	3
	T11b	Bus(With driver max. 41 passenger cap.)	3
	T13	Truck, Chassis cabin full weight min.12.000 kg	1
	T14	Truck, Chassis cabin full weight min.17.000 kg	1
	T21a	Pr. Cars with security system (Type and price to be determined by Gener. Secretar. of Presidency)	2
T22	Other vehicles (Type and price to be determined by Ministry of Finance)	8	
TURKISH GRAND NATIONAL ASSEMBLY	T05	Minibus (With driver max. 17 passenger cap.)	2
	T07	Pick-up (With driver 3 or 6- passenger cap.)	1
	T09	Panel	6
	T11b	Bus (With driver max. 41 passenger cap.)	1
SUPREME COURT	T02	Private Car	30
	T05	Minibus (With driver max. 17 passenger cap.)	3
PRIME MINISTRY	T01a	Private Car	1
	T02	Private Car	3
	T04	Offroad car (Min.4, max.8 passenger cap.)	1
	T05	Minibus (With driver max. 17 passenger cap.)	1
	T21a	Private Car with security system (Type and price to be determined by Ministry of Finance)	1
RELIGIOUS AFFAIRS ADMIN.	T05	Minibus (With driver max. 17 passenger cap.)	5
	T05	Minibus (With driver max. 17 passenger cap.)	15
	T02	Private Car	15
DISASTER & EMERGENCY MANAGEMENT	T09	Panel	1
	T22	Other vehicles (Type and price to be determined by Ministry of Finance)	18

JUSTICE MINISTRY	T02	Private Car	25
	T05	Minibus (With driver max. 17 passenger cap.)	5
	T05	Minibus (With driver max. 17 passenger cap.)	1
	T07	Pick-up (With driver 3 or 6- passenger cap.)	2
	T09	Panel	5
	T09	Panel	10
	T09	Panel	5
	T10	Midibus (With driver max. 26- passenger cap.)	2
	T11a	Bus (With driver min 27, max. 40- passenger cap.)	25
	T12	Truck, Chassis cabin full weight min.3.501 kg	1
	T13	Truck, Chassis cabin full weight min.12.000 kg	2
	T14	Truck, Chassis cabin full weight min.17.000 kg	1
NATIONAL DEFENSE MINISTRY	T02	Private Car	25
	T03	Station-Wagon	2
	T05	Minibus (With driver max. 17 passenger cap.)	9
	T06	Station Car (Offroad services)	1
	T07	Pick-up (With driver 3 or 6- passenger cap.)	4
	T08	Pick-up (Small truck, offroad services, with driver 3 or 6- passenger cap.)	4
	T09	Panel	6
	T10	Midibus (With driver max. 26- passenger cap.)	2
	T11a	Bus (With driver min 27, max. 40- passenger cap.)	3
	T12	Truck, Chassis cabin full weight min.3.501 kg	2
	T13	Truck, Chassis cabin full weight min.12.000 kg	1
	T16	Ambulance (Offroad services)	1
	T22	Other vehicles (Type and price to be determined by Ministry of Finance)	2
	T22	Other vehicles (Type and price to be determined by Ministry of Finance)	3
	T02	Private Car	30
	T03	Station- Wagon	6
	T05	Minibus (With driver max. 17 passenger cap.)	6
	T07	Pick-up (With driver 3 or 6- passenger cap.)	1
	T08	Pick-up (Small truck, offroad services, with driver 3 or 6- passenger cap.)	1
	T09	Panel	2
	T11b	Bus (With driver max. 41 passenger cap.)	1
	T13	Truck, Chassis cabin full weight min.12.000 kg	1
	T14	Truck, Chassis cabin full weight min.17.000 kg	1
	T15	Ambulance (With medical equipment)	1
	T22	Other vehicles (Type and price to be determined by Ministry of Finance)	19
	T02	Private Car	50
	T03	Station-Wagon	12
	T05	Minibus (With driver max. 17 passenger cap.)	21
	T07	Pick-up (With driver 3 or 6- passenger cap.)	15
	T08	Pick-up (Small truck, offroad services, with driver 3 or 6- passenger cap.)	12
	T09	Panel	22
	T10	Midibus (With driver max. 26- passenger cap.)	9
	T11a	Bus (With driver min 27, max. 40- passenger cap.)	7

	T12	Truck, Chassis cabin full weight min.3.501 kg	1
	T13	Truck, Chassis cabin full weight min.12.000 kg	2
	T14	Truck, Chassis cabin full weight min.17.000 kg	9
	T15	Ambulance (With medical equipment)	8
	T22	Other vehicles (Type and price to be determined by Ministry of Finance)	16
	T22	Other vehicles (Type and price to be determined by Ministry of Finance)	2
	T22	Other vehicles (Type and price to be determined by Ministry of Finance)	2
	T22	Other vehicles (Type and price to be determined by Ministry of Finance)	2
	T22	Other vehicles (Type and price to be determined by Ministry of Finance)	10
	T22	Other vehicles (Type and price to be determined by Ministry of Finance)	4
	T02	Private Car	20
	T05	Minibus (With driver max. 17 passenger cap.)	17
	T07	Pick-up (With driver 3 or 6- passenger cap.)	13
	T08	Pick-up (Small truck, offroad services, with driver 3 or 6- passenger cap.)	3
	T09	Panel	48
	T10	Midibus (With driver max. 26- passenger cap.)	4
	T15	Ambulance (With medical equipment)	4
	T02	Private Car	25
	T05	Minibus (With driver max. 17 passenger cap.)	22
	T07	Pick-up (With driver 3 or 6- passenger cap.)	17
	T09	Panel	7
	T10	Midibus (With driver max. 26- passenger cap.)	25
	T15	Ambulance (With medical equipment)	2
	T02	Private Car	1
	T05	Minibus (With driver max. 17 passenger cap.)	2
	T07	Pick-up (With driver 3 or 6- passenger cap.)	1
	T08	Pick-up (Small truck, offroad services, with driver 3 or 6- passenger cap.)	2
	T09	Panel	2
	T20	Bisiklet	20
INTERIOR MINISTRY	T01a	Private Car	10
	T04	Offroad car (Min.4, max.8 passenger cap.)	20
	T21a	Private Car with security system (Type and price to be determined by Ministry of Finance)	2
	T05	Minibus (With driver max. 17 passenger cap.)	1
	T07	Pick-up (With driver 3 or 6- passenger cap.)	1
	T08	Pick-up (Small truck, offroad services, with driver 3 or 6- passenger cap.)	1
	T02	Private Car	10
	T02	Private Car	10
GENDARMERIE GENERAL COMM.	T01a	Private Car	30
	T02	Private Car	100
	T05	Minibus (With driver max. 17 passenger cap.)	75
	T07	Pick-up (With driver 3 or 6- passenger cap.)	50

	T08	Pick-up (Small truck, offroad services, with driver 3 or 6-passenger cap.	100
	T09	Panel	100
	T11a	Bus (With driver min 27, max. 40- passenger cap.)	5
	T11b	Bus (With driver max. 41 passenger cap.)	2
	T12	Truck, Chassis cabin full weight min.3.501 kg	2
	T14	Truck, Chassis cabin full weight min.17.000 kg	2
	T15	Ambulance (With medical equipment)	2
	T22	Other vehicles (Type and price to be determined by Ministry of Finance)	5
	T13	Truck, Chassis cabin full weight min.12.000 kg	2
SECURITY GENERAL DIRECTORATE	T02	Private Car	200
	T04	Offroad car (Min.4, max.8 passenger cap.)	10
	T05	Minibus (With driver max. 17 passenger cap.)	20
	T07	Pick-up (With driver 3 or 6- passenger cap.)	2
	T08	Pick-up (Small truck, offroad services, with driver 3 or 6-passenger cap.	25
	T09	Panel	200
	T11a	Bus (With driver min 27, max. 40- passenger cap.)	15
	T11b	Bus (With driver max. 41 passenger cap.)	1
	T12	Truck, Chassis cabin full weight min.3.501 kg	10
	T13	Truck, Chassis cabin full weight min.12.000 kg	1
	T14	Truck, Chassis cabin full weight min.17.000 kg	1
	T15	Ambulance (With medical equipment)	2
	T17	Pick-up (Small truck,) (To be converted to hearse)	1
	T19	Motorbikes min. 600 cc. cap.	30
	T22	Other vehicles (Type and price to be determined by Ministry of Finance)	1
	T02	Private Car	150
	T04	Offroad car (Min.4, max.8 passenger cap.)	16
	T09	Panel	60
	T19	Motorbikes min. 600 cc. cap.	60
COAST GUARD COMMAND	T05	Minibus (With driver max. 17 passenger cap.)	1
	T07	Pick-up (With driver 3 or 6- passenger cap.)	1
	T09	Panel	5
FOREIGN AFFAIRS MINISTRY	T04	Offroad car (Min.4, max.8 passenger cap.)	8
	T05	Minibus (With driver max. 17 passenger cap.)	6
	T07	Pick-up (With driver 3 or 6- passenger cap.)	1
	T18	Motorbikes min. 600 cc. cap.	5
	T21a	Private Car with security system (Type and price to be determined by Ministry of Finance)	10
	T21b	Private Car with security system (Type and price to be determined by Ministry of Finance)	8
FINANCE MINISTRY	T09	Panel	5
	T22	Other vehicles (Type and price to be determined by Ministry of Finance)	100
REVENUE MANAGEMENT	T09	Panel	10
NATIONAL EDUCATION MINISTRY	T02	Private Car	65
	T05	Minibus (With driver max. 17 passenger cap.)	25

	T07	Pick-up (With driver 3 or 6- passenger cap.)	20
	T11a	Bus (With driver min 27, max. 40- passenger cap.)	2
HEALTH MINISTRY	T15	Ambulance /With medical equipment)	800
	T16	Ambulance (Offroad services)	400
	T15	Ambulance /With medical equipment)	300
	T16	Ambulance (Offroad services)	100
	T18	Motorbikes min. 600 cc. cap.	5
	T18	Motorbikes min. 600 cc. cap.	5
	T22	Other vehicles (Type and price to be determined by Ministry of Finance)	60
	T02	Private Car	25
	T05	Minibus (With driver max. 17 passenger cap.)	20
	T07	Pick-up (With driver 3 or 6- passenger cap.)	50
	T10	Midibus (With driver max. 26- passenger cap.)	5
	T11a	Bus (With driver min 27, max. 40- passenger cap.)	5
	T12	Truck, Chassis cabin full weight min.3.501 kg	5
	T19	Motorbikes min. 600 cc. cap.	10
	T13	Truck, Chassis cabin full weight min.12.000 kg	7
	T22	Other vehicles (Type and price to be determined by Ministry of Finance)	15
	T20	Bikes	50.000
T09	Panel	10	
T09	Panel	10	
CULTURE AND TOURISM MINISTRY	T11b	Bus (With driver max. 41 passenger cap.)	10
	T02	Private Car	10
	T12	Truck, Chassis cabin full weight min.3.501 kg	1
	T05	Minibus (With driver max. 17 passenger cap.)	5
MINISTRY OF FAMILY & SOCIAL POLICIES	T02	Private Car	15
	T05	Minibus (With driver max. 17 passenger cap.)	15
	T07	Pick-up (With driver 3 or 6- passenger cap.)	15
	T10	Midibus (With driver max. 26- passenger cap.)	5
	T15	Ambulance /With medical equipment)	10
	T05	Minibus (With driver max. 17 passenger cap.)	1
MINISTRY OF SCIENCE, INDUSTRY & TECHNOLOGY	T09	Panel	2
MINISTRY OF ENVIRONMENT AND URBAN PLANNING	T05	Minibus (With driver max. 17 passenger cap.)	3
	T08	Pick-up (Small truck, offroad services, With driver 3 or 6 - passenger cap.)	5
	T02	Private Car	3
MINISTRY OF FOOD, AGRICULTURE & LIVESTOCK	T05	Minibus (With driver max. 17 passenger cap.)	2
	T08	Pick-up (Small truck, offroad services, With driver 3 or 6 - passenger cap.)	7
	T08	Pick-up (Small truck, offroad services, With driver 3 or 6 - passenger cap.)	3
	T09	Panel	5
	T11a	Bus (With driver min 27, max. 40- passenger cap.)	2
	T08	Pick-up (Small truck, offroad services, With driver 3 or 6 - passenger cap.)	1
	T08	Pick-up (Small truck, offroad services, With driver 3 or 6 - passenger cap.)	7
	T22	Other vehicles (Type and price to be determined by Ministry	1

		of Finance)	
	T09	Panel	15
	T05	Minibus (With driver max. 17 passenger cap.)	2
	T07	Pick-up (With driver 3 or 6- passenger cap.)	10
	T08	Pick-up (Small truck, offroad services, With driver 3 or 6 - passenger cap.)	2
	T09	Panel	2
	T10	Midibus (With driver max. 26- passenger cap.)	1
	T13	Truck, Chassis cabin full weight min.12.000 kg	2
	T09	Panel	2
	T02	Private Car	12
	T04	Offroad car (Min.4, max.8 passenger cap.)	2
	T05	Minibus (With driver max. 17 passenger cap.)	9
	T07	Pick-up (With driver 3 or 6- passenger cap.)	5
	T08	Pick-up (Small truck, offroad services, With driver 3 or 6 - passenger cap.)	10
	T09	Panel	44
	T09	Panel	4
	T11a	Bus (With driver min 27, max. 40- passenger cap.)	1
	T14	Truck, Chassis cabin full weight min.17.000 kg	1
	T08	Pick-up (Small truck, offroad services, With driver 3 or 6 - passenger cap.)	1
	T09	Panel	1
MINISTRY OF CUSTOMS AND TRADE	T09	Panel	5
	T05	Minibus (With driver max. 17 passenger cap.)	2
	T08	Pick-up (Small truck, offroad services, With driver 3 or 6 - passenger cap.)	3
	T09	Panel	5
	T22	Other vehicles (Type and price to be determined by Ministry of Finance)	4
	T05	Minibus (With driver max. 17 passenger cap.)	3
	T09	Panel	4
MINISTRY OF FORESTRY AND WATER AFFAIRS	T09	Panel	3
	T08	Pick-up (Small truck, offroad services, With driver 3 or 6 - passenger cap.)	5

VEHICLES TO BE PROCURED BY SPECIAL BUDGET MANAGERMENTS IN 2018

MANAGEMENT	T Table	VEHICLE TYPE	QTY/ea
ANKARA UNIVERSITY	T02	Private Car	1
	T15	Ambulance /With medical equipment)	2
İSTANBUL UNIVERSITY	T22	Other vehicles (Type and price to be determined by Ministry of Finance)	1
	T15	Ambulance /With medical equipment)	6
BOĞAZIÇI UNIVERSITY	T02	Private Car	1
YILDIZ TECH. UNIVERSITY	T02	Private Car	2
EGE UNIVERSITY	T02	Private Car	1

DOKUZ EYLÜL UNIVERSITY	T02	Private Car	1
ULUDAĞ UNIVERSITY	T02	Private Car	2
SELÇUK UNIVERSITY	T02	Private Car	5
AKDENİZ UNIVERSITY	T11a	Bus (With driver min 27, max. 40- passenger cap.)	1
	T11b	Bus (With driver max. 41 passenger cap.)	1
	T02	Private Car	1
CUMHURİYET UNIVERSITY	T02	Private Car	1
ATATÜRK UNIVERSITY	T04	Offroad car (Min.4, max.8 passenger cap.)	1
İNÖNÜ UNIVERSITY	T02	Private Car	2
DİCLE UNIVERSITY	T18	Motorbike (max. 600 cc.cap.)	1
GAZİANTEP UNIVERSITY	T15	Ambulance /With medical equipment)	1
GEBZE TECH. UNIVERSITY	T12	Truck, Chassis cabin full weight min.3.501 kg	1
HARRAN UNIVERSITY	T02	Private Car	1
ADNAN MENDERES UNIVERSITY	T05	Minibus (With driver max. 17 passenger cap.)	1
PAMUKKALE UNIVERSITY	T02	Private Car	1
SAKARYA UNIVERSITY	T02	Private Car	2
MANİSA CELAL BAYAR UNIVERSITY	T09	Panel	1
KAFKAS UNIVERSITY	T08	Pick-up (Small truck, offroad services, With driver 3 or 6 -passenger cap.)	1
DUMLUPINAR UNIVERSITY	T04	Offroad car (Min.4, max.8 passenger cap.)	1
MUĞLA SITKI KOCAMAN UNIVERSITY	T02	Private Car	2
AHI EVRAN UNIVERSITY	T02	Private Car	1
ERZİNCAN UNIVERSITY	T04	Offroad car (Min.4, max.8 passenger cap.)	1
	T02	Private Car	1
AKSARAY UNIVERSITY	T20	Bisiklet	1
HİTİT UNIVERSITY	T11b	Bus (With driver max. 41 passenger cap.)	1
ADIYAMAN UNIVERSITY	T08	Pick-up (Small truck, offroad services, With driver 3 or 6 -passenger cap.)	1
	T02	Private Car	1
SİNOP UNIVERSITY	T11b	Bus (With driver max. 41 passenger cap.)	1
KARABÜK UNIVERSITY	T08	Pick-up (Small truck, offroad services, With driver 3 or 6 -passenger cap.)	2
OSMANİYE KORKUT ATA UNIVERSITY	T07	Pick-up (With driver 3 or 6- passenger cap.)	1
MUŞ ALPASLAN UNIVERSITY	T12	Truck, Chassis cabin full weight min.3.501 kg	1
BAYBURT UNIVERSITY	T15	Ambulance /With medical equipment)	1
HAKKARİ UNIVERSITY	T05	Minibus (With driver max. 17 passenger cap.)	1
İĞDIR UNIVERSITY	T22	Other vehicles (Type and price to be determined by Ministry of Finance)	1
İSKENDERUN TECH. UNIVERSITY	T05	Minibus (With driver max. 17 passenger cap.)	1
ALANYA ALAADDİN KEYKUBAT UNIVERSITY	T05	Minibus (With driver max. 17 passenger cap.)	1
İZMİR BAKIRÇAY UNIVERSITY	T05	Minibus (With driver max. 17 passenger cap.)	1
	T07	Pick-up (With driver 3 or 6- passenger cap.)	1
İZMİR DEMOKRASİ UNIVERSITY	T10	Midibus (With driver max. 26- passenger cap.)	1
TURKISH SCIENTIFIC & TECHNOLOGICAL RESEARCH INSTITUTE	T08	Pick-up (Small truck, offroad services, With driver 3 or 6 -passenger cap.)	2
HIGHER EDUCATION, CREDITS AND HOSTELS BOARD	T07	Pick-up (With driver 3 or 6- passenger cap.)	5
	T11a	Bus (With driver min 27, max. 40- passenger cap.)	5
FORESTRY GENERAL DIRECT.	T04	Offroad car (Min.4, max.8 passenger cap.)	5

	T05	Minibus (With driver max. 17 passenger cap.)	2
	T08	Pick-up (Small truck, offroad services, With driver 3 or 6 -passenger cap.)	8
	T14	Truck, Chassis cabin full weight min.17.000 kg	2
	T05	Minibus (With driver max. 17 passenger cap.)	3
	T07	Pick-up (With driver 3 or 6- passenger cap.)	1
	T08	Pick-up (Small truck, offroad services, With driver 3 or 6 -passenger cap.)	30
	T14	Truck, Chassis cabin full weight min.17.000 kg	3
	T04	Offroad car (Min.4, max.8 passenger cap.)	1
	T05	Minibus (With driver max. 17 passenger cap.)	1
	T08	Pick-up (Small truck, offroad services, With driver 3 or 6 -passenger cap.)	3
CHARITIES GENERAL DIRECT.	T05	Minibus (With driver max. 17 passenger cap.)	1
TURKISH BORDERS & COASTS HEALTH GENERAL DIRECTORATE	T07	Pick-up (With driver 3 or 6- passenger cap.)	1
TURKISH STANDARDS INSTITUTE (TSE)	T07	Pick-up (With driver 3 or 6- passenger cap.)	15
TURKISH COOPERATION & COORDINATION AGENCY	T04	Offroad car (Min.4, max.8 passenger cap.)	10
MINERAL RESEARCH AND EXPLOR. GENERAL DIRECTORATE (MTA)	T05	Minibus (With driver max. 17 passenger cap.)	1
	T12	Truck, Chassis cabin full weight min.3.501 kg	1
	T05	Minibus (With driver max. 17 passenger cap.)	2
	T07	Pick-up (With driver 3 or 6- passenger cap.)	3
	T09	Panel	5
	T11a	Bus (With driver min 27, max. 40- passenger cap.)	15
	T12	Truck, Chassis cabin full weight min.3.501 kg	1
	T13	Truck, Chassis cabin full weight min.12.000 kg	2
	T14	Truck, Chassis cabin full weight min.17.000 kg	1
	T15	Ambulance /With medical equipment)	5
	T12	Truck, Chassis cabin full weight min.3.501 kg	10
	T13	Truck, Chassis cabin full weight min.12.000 kg	10
	T14	Truck, Chassis cabin full weight min.17.000 kg	8
STATE HIGHWAYS ADMIN.(KGM)	T07	Pick-up (With driver 3 or 6- passenger cap.)	7
	T12	Truck, Chassis cabin full weight min.3.501 kg	7

Table (III)

List of vehicles to be purchased for Regulatory & Supervising Managements in 2018 (III)

MANAGEMENT	T TABLE	VEHICLE TYPE	QTY/ea
INFORMATION & COMMUNICATION TECHNOLOGIES AUTHORITY	T04	Offroad car (Min.4, max.8 passenger cap.)	8
	T11b	Bus (With driver max. 41 passenger cap.)	1
BANKING REGULATORY & SUPERVISORY BOARD (BDDK)	T05	Minibus (With driver max. 17 passenger cap.)	1

Important Projects That Had Been Tendered within 2017 and Those Lagging into The New Year

Dear Readers;

Last year's major projects of primary importance that were followed up by our correspondents had been reported in various issues of **DETAY Economic Magazine** and our website www.detayhaber.com.tr. Some of them are BOTAS's naturalgas pipelines, YEKDEM's renewable energy projects, İstanbul M.Municipality 's subway projects, Health Ministry's hospital constructions in various provinces, TEİAŞ's energy transmission line projects, and TOKİ's housing and social facility projects.

You can find the list of around 126 important projects, with the details as listed below, monitored in 2017 and those that lagged into 2018.

The latest issue no. of **DETAY Economic Magazine** in which a report took place is also given for reference

PROJECTS ON THE AGENDA

Tenderer : **DIRECTORATE (MINISTRY OF TRANSPORT, MARITIME & COMMUNICATIONS)**

Project : **ANKARA SUBWAY (M4) ATATÜRK CULTURE CENTRE –KIZILAY LINE PROJECT**

Financing : Local source

Latest State : **2017/576179** Registered Tender: For Atatürk Kültür Merkezi AKM (M4) - Kızılay Lines and electromechanical systems procurement, assembly and commissioning services, biddings were held on November 14 and 15, 2017 for which 6 firms had been invited and over an estimated cost of 560.181.060,83 TL the lowest price offer came from **KOLİN İNŞAAT** as 503.700.000,00 TL. (DETAY-1551)

Project : **RİZE-ARTVİN AIRPORT INFRASTRUCTURE PROJECT**

Financing : Local source

Latest State : **2016/416372** Registered Tender : Rize-Artvin Airport Infrastructure construction was tendered on 12 Jan. 2017. Quoting 1.078.434.462,28 TL, **CENGİZ İNŞAAT+AGA İNŞAAT** joint venture received the contract (DETAY-1508)

Project : **ÇUKUROVA REGIONAL AIRPORT PROJECT**

Financing : Local source

Latest State : **2016/108770** Registered Tender: Airport construction was tendered on 16 May 2016. Over an estimated cost of 350.000.000,00 TL , **HAZARYOL - BUDAKYOL** joint venture received the contract at a cost of 224 million874 .000 TL. (DETAY-1507)

Tenderer : **ANKARA METROPOLITAN MUNICIPALITY**

Project : **KANAL ANKARA PROJECT**

Financing : Local source -işletme

Latest State : Ankara infrastructure tender was held made on October 13, 2017. Developed by ex-Mayor of Ankara Melih Gökçek, "Kanal Ankara Project" aims to create a strong green recreational zone between the İmrahor Viaduct and the Eymir Lake Basin and a 9.5- km line and 290 -hectare area in the city center. The lowest bid in the tender in which 4 firms participated came from **İNCEKAYA İNŞ. SAN. VE TİC. LTD.ŞTİ VE ENAM İNŞ. TAAH. GIDA SAN. TİC. A.Ş.** joint venture as 89 million TL.. Final decision will be given by new Mayor Mustafa Tuna. (DETAY-1546)

Tenderer : **BOLU MUNICIPALITY**

Project : **WASTEWATER TREATMENT PLANT 2. STAGE CONSTRUCTION PROJECT**

Financing : Local source

Latest State : **2017/427405** Registered Tender: Wastewater treatment plant 2nd stage works and revision (77.000 m3/day) Project was tendered on 27 Sep. 2017. Over an estimated cost of 44.268.444,83 TL, 9 firms contested and. The lowest bid offer was 34.318.097,79 TL quoted by **ÇEVTAŞ ÇEVRE TEKNOLOJİLERİ**. (DETAY-1544)

Tenderer : **PETROLEUM PIPELINES CO. (BOTAŞ)**

Project : **NORTH MARMARA NATURALGAS STORAGE EXPANSION (PHASE III) PROJECT**

Financing : Local source -European Investment Bank (EİB)

Latest State : After the preselection held on 16.06.2017, eligible firms submitted their offers over an estimated cost of 4.543.771.906 TL. But only **RÖNESANS ENDÜSTRİ-RENAISSANCE HEAVY INDUSTRIES** (Russia)'s envelope was opened (DETAY-1557) . Its offer 2.589.000.000 TL .

The other qualified firms:

- SAIPEM S.p.A. (ITALY) - ÇALIK ENERJİ SAN. VE TİC. A.Ş. (TURKEY) JOINT VENTURE
- INTECSA INGENIERIA INDUSTRIAL S.A. (SPAIN)
- L&T HYDROCARBON ENGINEERING LIMITED (INDIA)
- SAPURA FABRICATION (MALAYSIA), TEKFEN (TURKEY) & SAPURA DRILLING (HONG KONG) JOINT VENTURE
- ACS (SPAIN) - GAMA (TURKEY) JOINT VENTURE
- TCC (CHINA) – COOEC (CHINA) - COSL (CHINA) JOINT VENTURE
- İLK (TURKEY) - CPECC (CHINA) – CNOOC (CHINA) JOINT VENTURE (Conditional agreement)
- CHENGDA (CHINA) - HONGHUA (CHINA) - KOLİN (TURKEY) - KALYON (TURKEY) (Conditional agreement)

Project : **TURKSTREAM LAND SECTION 1ST STAGE PROJECT**
Financing : Local source – with credit
Latest State : 48 inch diameter and 68+846,21 m long TurkStream Land Section-1 Naturalgas Pipelines Construction Project started. It starts from Kıyıköy PİG (Thrace-Kırklareli) station and terminates at Misinli PİG (Çorlu-Tekirdağ) station. BOTAŞ finalised the Land Survey Mapping and Expropriation Engineering Services Tender and awarded the contract to **Kartal Harita Müh. Taah. Tic. Ltd. Şti.**. The firm determined the final route in line with the opinions of the public institutions and organizations within the framework of the contract and carried out the studies on the expropriation and EIA (ÇED) Report.. When the project is completed, it will consist of two parallel pipelines, each of which will have a capacity of transporting 15,75 billion m3 of gas per year. Each line will be laid by combining thousands of separate pipe sections. The first line to be connected to the Turkish main distribution network in Lüleburgaz will be developed by BOTAŞ. The second line will continue by land to the Turkish-Greek border. It will be built with Gazprom and BOTAS partnership.. (DETAY-1557)

Project : **ADANA-CEYHAN TUGBOAT PORT REHABILITATION PROJECT**
Financing : Local source
Latest State : **2017/504135** Registered Tender: Adana Ceyhan Tugboat Port Rehabilitation Project was tendered on 7 Dec. 2017. Over an estimated cost of 25.073.850,63 TL , the lowest bid offer of 29.890.000,00 TL was quoted by **UĞRAŞ İNŞAAT.** (DETAY-1554)

Project : **ARAKLI-ARDEŞEN ÇAYELİ DISTRICTS AND ARSİN OSB NATURALGAS PIPELINE PROJECT**
Financing : Local Source
Latest State : **2017/197567** Registered Tender: Bids were received on 11 May2017. Quoting 62.855.356,00 TL **MEGARON+TEK-İMAŞ** joint venture received the contract (DETAY-1526)

Project : **ARTVİN NATURALGAS PIPELINE PHASE- 1 PROJECT**
Financing : Local Source
Latest State : **2016/551753** Registered Tender: Artvin Naturalgas Pipelines Phase -1 Tender was held on 12 Jan. 2017. Quoting 19.428.332,00 TL, **ÖZSOY İNŞAAT** received the contract (DETAY-1508)

Tenderer : **STATE AIRPORTS MANAGEMENT (DHMİ)**
Project : **ÇUKUROVA REGIONAL AIRPORT SUPERSTRUCTURE PROJECT**
Financing : Local source
Latest State : **2017/94088** Registered Tender: Çukurova Regional Airport Superstructure Construction tender was canceled on 10 Oct. 2017. Applications had been received on 23 March 2017. DHMİ announced that cancellation was made since the changes earlier made in the technical specifications affected the assessment of proposals and the reconstruction of the manufactured facilities was contrary to the principle of effective and efficient use of public resources.". (DETAY-1546)

Tenderer : **STATE HYDRAULIC WORKS (DSİ)**
Project : **SAMSUN 19 MAYIS DRINKINGWATER TREATMENT PLANT PROJECT**
Financing : Local Source
Latest State : **2017/517217** Registered Tender: The Tender for Samsun 19 Mayıs Drinkingwater Treatment Plant with 100.000 m3 cap. was held on 15 Nov. 2017. Over an estimated cost of 37.809.968,55 TL the lowest bid offer of 32.100.000 TL was quoted by **KAMER İNŞAAT.**

Project : **GEMLİK DRINKINGWATER TREATMENT PLANT PROJECT**
Financing : Local Source
Latest State : **2017/432685** Registered Tender: The Tender for Bursa Gemlik Drinkingwater Treatment Plant was held on 5 Oct. 2017. Over an estimated cost of 38.277.632,98 TL 10 firms submitted offers.. The lowest bid offer of 29.941.000,00 TL was quoted by **MİTAŞ PROJE + ARSAN ARITMA** joint venture. (DETAY-1545)

Project : **AKSARAY DRINKINGWATER TREATMENT PLANT PROJECT**
 Financing : Local Source
 Latest State : **2016/597557** Registered Tender: The tender for Aksaray Drinkingwater Treatment Plant was held on 14 Feb. Over an estimated cost of 23.675.260,98 TL, **BETAŞ BETON VE PREFABRIKE YAPI ELEMANLARI** received the contract quoting 25.895.000,00 TL (DETAY-1513)

Tenderer : **STATE HYDRAULIC WORKS (DSİ) 6. BÖLGE MÜDÜRLÜĞÜ**
 Project : **OSMANIYE SABUNSUYU ÇATAK DAM AND HPP PROJECT**
 Financing : Local Source
 Latest State : Çatak DAM is planned to be constructed within the scope of "Sabunsuyu Çatak Dam Planning and Project Services" for irrigation water, energy and drinking water supplies within the boundaries of Osmaniye's Düziçi District. The Project has an estimated cost of 1 008 803 071 lira and it will enable the supply of water from Çatak Dam, instead of the underground water wells and Sabunsuyu resources by open channel, to irrigate Haruniye and Sabunsuyu lands areas by using a high pressure irrigation system. Thus, there will be a significant decrease in irrigation water costs, and a rise in irrigation rates, irrigation efficiency and profitability. In addition, Çatak Dam Hydroelectric Power Plant planned to be constructed will supply energy as well as drinking water for Düziçi District. The installed capacity of the hydroelectric power plant will be 11.55 MW. Estimated to have an economic life of 50 years, all the proposed constructions will be completed in 4 years. **Undertaker of the planning and project services contract:** The tender for the planning and project services was held in 2015 under file no 2014/174928 for Sabunsuyu Çatak Dam . Over an estimated cost of 2.014.880,11 TL the contract was awarded to **TEMLSU ULUSLARARASI MÜHENDİSLİK HİZ. A.Ş.** quoting 1.650.000,00 TL. Contract date: 30.04.2015.

Tenderer : **STATE HYDRAULIC WORKS (DSİ) 25. BÖLGE MÜDÜRLÜĞÜ**
 Project : **ÇANAKKALE 2. STAGE DRINKINGWATER TREATMENT PLANT PROJECT**
 Financing : Local Source
 Latest State : **2017/512854** Registered Tender: Bids were received on 22 Nov. 2017. Over an estimated cost of 45.236.102,00 TL, and limit value of 33.703.352,79 TL 9 offers were submitted.. The lowest bid offer of 34.723.000,00 TL was quoted by **HMC YAPI + FABER İNŞAAT** joint venture. (DETAY-1552)

Tenderer : **ETİ MADEN İŞLETMELERİ GENEL MÜDÜRLÜĞÜ**
 Project : **BİGADIÇ CONCENTRATOR PLANT PROJECT**
 Financing : Local source
 Latest State : **2017/493598** Registered Tender: Balıkesir Bigadiç concentrator plant project (with 1.000.000 ton/year tuvenane ore washing cap.) Bids were received on 5 Dec. 2017. Over an estimated cost of 99.987.553,42 TL the lowest bid offer of 77.400.000,00 TL was submitted by **METALEKS İNŞ + ÜNİTEK İNŞAAT** joint venture. (DETAY-1554)

Project : **KÜTAHYA EMET SULPHURIC ACID PLANT PROJECT**
 Financing : Local source
 Latest State : **2016/150373** Registered Tender: For the Kütahya Emet Sulphuric Acid Production Plant with 350.000 Ton/year cap. applications were received on 18 Sep. 2017. The evaluation is underway. Applicants : (DETAY-1543)

FIRMS

- **ALSİM ALARKO**
- **DALGIÇ RAY + DALGIÇLAR İNŞAAT**
- **EKON ENDÜSTRİ**
- **FERNAS İNŞAAT + MEGA ENDÜSTRİYEL İNŞAAT**
- **GAMA ENDÜSTRİ TESİSLERİ**
- **METALEKS İNŞAAT + İMAJ ALTYAPI**
- **ÖZTAŞ İNŞAAT**
- **RÖNESANS ENDÜSTRİ**
- **TEFİROM İNŞAAT**
- **TEKFEN İNŞAAT**

Tenderer : **ELECTRICITY GENERATION CO. (EÜAŞ)**
 Project : **ALIAĞA 120 MW CAPACITY FLOATING POWER PLANT**
 Financing : Local source
 Latest State : **2017/528243** Registered Tender: 120 MW cap. Aliağa floating power plant tender was held on 23 Nov. 2017. 5 submitted offers. Over an estimated cost of 218.712.069,00 TL the lowest bid offer of 181.680.000 TL was submitted by **TERSAN TERSANECİLİK.** (DETAY-1553)

Project : **18 MART ÇAN TS 2X160 MW CAPACITY UNITS BGD PLANT PROJECT**
 Financing : Local source
 Latest State : **2017/272315** Registered Tender: Bids were received on 18 July 2017. Evaluation is underway. (**DETAY-1535**):
 Project scope: 18 Mart Çan Thermal P.Plant Gas Desulphurisation (BGD) Plant operated with a limestone wet washing system for 1 and 2 Units at 2x160 MWe capacity and all the modifications in the related units of the plant.
 The applicants are:

- **AST YAPI + HİDROKAR İNŞAAT**
- **BESTAŞ İNŞAAT + DEMCE YAPI**
- **CHİNA MACHİNERİ**
- **ÇALIŞ ENERJİ**
- **DALGIÇRAY İNŞAAT + MET GRUP + İMAJ ALTYAPI**
- **DBH YOL + YEDİGÖZE İNŞ + GALA ALTYAPI**
- **EKOM ENDÜSTRİ**
- **FERNAS İNŞAAT + YAPI VE YAPI İNŞAAT**
- **İNER RAU + UET URAN ENDÜSTRİ**
- **METALEKS İNŞAAT + KOLİN İNŞAAT + AKKOL ENERJİ**
- **ÖZTAŞ İNŞAAT**
- **PEMCO + EFOR ENDÜSTRİ**
- **RÖNESANS ENDÜSTRİYEL**
- **SİNOTEK MADENCİLİK**
- **TEFİROM İNŞAAT**
- **VADİ BOTANİK + AGA ENERJİ**

Tenderer : **ENERGY MARKET REGULATORY AUTHORITY (EPDK)**

Project : **RENEWABLE ENERGY PROJECTS**

Financing : The firm's

Latest State : The list of plants applying for Renewable Energy Resources Support Mechanism (YEKDEM) to benefit the new year incentives has been disclosed. By end of October 2017, more than 700 plants with over 19.000MW submitted application as follows: (**DETAY-1551**)

Resource Type	Plant type	Applicant's Cap. (Mwe)
Biomass	Herbal and Animal Waste	8
Biomass	Vegetal oil waste	1
Biomass	Biogas	24
Biomass	Garbage gas	198
Biomass	Animal Waste	26
Biomass	Herbal and Animal Waste	1
Biomass	Tire waste	12
Biomass	Forest waste	35
Biomass	Agricult. waste	9
Biomass	Agricult. And animal waste	19
Biomass	Agricult. Forest And animal waste	12
Solar	Photovoltaic	14
Hydraulic	Channel	5.210
Hydraulic	River	987
Hydraulic	With reservoir	5.426
Geothermal	Geothermal	997
Wind	Wind	6.0

Project : **RENEWABLE ENERGY PROJECTS**

Latest State : Negotiations were completed on 3 August 2017 for 1,000 MW wind power plant and turbine production to raise wind energy capacity by 17% in Turkey. After 30 rounds of auctions the contract was awarded to **SIEMENS-TÜRKERLER-KALYON OGG** quoting 3.48 cent/KWH. The locations are Kayseri-Niğde, Sivas, Edirne-Kırklareli-Tekirdağ, Ankara-Çankırı-Kırıkkale, Bilecik-Kütahya-Eskişehir (**DETAY-1537**)

Project : **ARTVİN NATURALGAS PIPELINE PROJECT**

Financing : Operational rights

Latest State : The Energy Market Regulatory Authority (EPDK) held the tender on 27 March 2017 for distribution of naturalgas to Artvin among the areas that have had no naturalgas supplies up to now. **Arsan İnş** and **Akmercan** offered 0 krş/kwh and thus the cost of distribution became 0 TL. This means that naturalgas subscribers in Artvin will pay nothing for their consumption for the 1st 8 years. (**DETAY-1519**)

Tenderer : **İSTANBUL METROPOLİTAN MUNICIPALITY**
 Project : **SUBWAY PROJECTS COMPRISING 6 LINES**
 Financing : Local Source -Credit
 Latest State : İstanbul Metropolitan Municipality canceled 6 subway tenders as notified to the bidders on 29 Dec. 2017 (DETAY-1558) . The subject lines and winners are as follows:

Kaynarca-Pendik-Tuzla,

The MUNICIPALITY 's Raylı Sistem Daire Başkanlığı, Avrupa Yakası Raylı Sistem Müdürlüğü held the tender under file no **2016/311081** over an estimated cost of 1.417.538.734,39 For Kaynarca – Pendik – Tuzla Subway Lines Civil works, electromechanical works, assembly and commissioning services and quoting 1.613.815.000,00 TL **ALSİM ALARKO – CENGİZ İNŞAAT JOİNT VENTURE** received the contract

Ümraniye-Ataşehir-Göztepe,

The Municipality's Raylı Sistem Daire Başkanlığı, Avrupa Yakası Raylı Sistem Müdürlüğü held the tender under file no **2016/311079** over an estimated cost of 2.182.165.754,30 for Ümraniye-Ataşehir-Göztepe Subway Lines Civil works, electromechanical works, assembly and commissioning services and quoting 2.469.924.400 TL , **GÜLERMAK AĞIR SANAYİ – NUROL İNŞAAT JOİNT VENTURE** received the contract

Çekmeköy-Sancaktepe-Sultanbeyli,

The Municipality's Raylı Sistem Daire Başkanlığı, Avrupa Yakası Raylı Sistem Müdürlüğü held the tender under file no **2016/311083** over an estimated cost of 2.058.446.722,05 for Çekmeköy –Sancaktepe- Sultanbeyli Subway Lines and Sarıgazi (Hastane)-Taşdelen-Yenidoğan Subway Lines Civil works, electromechanical works, assembly and commissioning services and quoting 2.342.385.742,09 TL, **DOĞUŞ İNŞAAT – ÖZALTIN İNŞAAT – YAPI MERKEZİ İNŞAAT JOİNT VENTURE** received the contract

Kirazlı-Halkalı,

The Municipality's Raylı Sistem Daire Başkanlığı, Avrupa Yakası Raylı Sistem Müdürlüğü held the tender under file no **2016/306719** over an estimated cost of 2.112.656586,93 for Kirazlı-Halkalı Subway Lines Civil works, electromechanical works, underground transfer centre (Carpark) and depot area construction, and quoting 2.414.401.632,00 TL, **MAKYOL İNŞ. – ASTUR İNŞ. – İC İÇTAŞ İNŞ. – KALYON İNŞ. JOİNT VENTURE** received the contract.

Başakşehir-Kayaşehir

The Municipality's Raylı Sistem Daire Başkanlığı, Avrupa Yakası Raylı Sistem Müdürlüğü held the tender under file no **2016/303118** Over an estimated cost of 846.210.927,87 for Başakşehir-Kayaşehir Subway Lines Civil works, electromechanical works and quoting 969.114.610,00 TL, **ÖZGÜN YAPI – SÖĞÜT İNŞAAT – ŞENBAY MADENCİLİK JOİNT VENTURE** received the contract

Mahmutbey-Bahçeşehir

The Municipality's Raylı Sistem Daire Başkanlığı, Avrupa Yakası Raylı Sistem Müdürlüğü held the tender under file no **2017/50203** over an estimated cost of 3.099.751.852,01 TL, and limit value of 2.099.660.893,00 TL, for Mahmutbey-Bahçeşehir-Esenyurt Subway Lines Civil works, electromechanical works and quoting 3.049.994.729,30 TL, **MAKYOL İNŞAAT A.Ş.-İC İÇTAŞ İNŞAAT SANA Yİ VE TİCARET A. Ş., ASTUR İNŞAAT VE TİCARET A.Ş. JOİNT VENTURE** received the contract

Project : **SMART TOLL SYSTEM PROJECT**
 Financing : Local Source
 Latest State : **2017/464696** Registered Tender: Tender was held on 8 November for İstanbul smart toll system establishment. Over an estimated cost of 64.092.387,75 TL, only **İSTANBUL BİLİŞİM VE AKILLI KENT TEKNOLOJİLERİ A.Ş. (İSBK A.Ş.)** participated in the tender and quoted 58.819.501,00 TL (DETAY-1550)

Project : **RÜMELİ HİSARÜSTÜ-AŞIYAN FUNICULAR LINE PROJECT**
 Financing : Local Source
 Latest State : **2016/513556** Registered Tender: The contract for Rumeli Hisarüstü-Aşıyan Funicular Lines Civil works, electromechanical works and vehicle procurement was awarded at a cost of 114.392.854,00 TL, quoted by **METROSTAV ANKARA İNŞAAT TAAHHÜT SANAYİ VE TİCARET A.Ş. (DETAY-1532)**

Project : **HALIÇ-UNKAPANI ROAD TUBULAR CROSSING PROJECT**
 Financing : Local Source
 Latest State : İstanbul Metropolitan Municipality held the tender on 26 July 2016 under file no **2016/210419** covering Haliç-Unkapanı land Road Tubular Crossing construction works and at the 2nd round the lowest bid offer was 2.098.942.455 TL, quoted by **STFA+YAPI MERKEZİ +ASL İNŞAAT** joint venture. (DETAY-1518)

Tenderer : İSTANBUL WATER AND SEWERAGE ADMINISTRATION (İSKİ)**Project : EUROPEAN SIDE WASTEWATER TREATMENT PLANT PROJECT****Financing : Local Source****Latest State : 2017/425175** Registered Tender: The Tender was held on 16 October 2017 for operation of the European side wastewater treatment facilities . Over an estimated cost of 205.482.630,00 TL two firms contested. The lowest bid offer was 161.906.807,00 TL, submitted by **BİNAŞ+GÜVEN İNŞ.** (DETAY-1547)**Project : ASIAN SIDE WASTEWATER TREATMENT PLANT PROJECT****Latest State : 2017/338684** Registered Tender: The Tender was held on 5 Sep. 2017 for the Asian side wastewater treatment facilities. Over an estimated cost of **126.805.178,34 TL** **REMONDİS SU VE ATIK SU TEK. A.Ş. +MASS ARITMA SİST. A.Ş.** received the contract quoting 92.603.100,00 TL (DETAY-1541)**Project : BALTALIMANI BIOLOGICAL WASTEWATER TREATMENT PLANT PROJECT****Financing : Local Source****Latest State : 2016/72490** Registered Tender: The Tender was held on 20 June 2017 for the Baltalımanı Biological Wastewater treatment plant facilities. The lowest bid offer was 315.400.000,00 TL quoted by **NUROL + AKTOR ANONYMİ TEHNİKİ.** (DETAY-1531)**Project : ÖMERLİ DRINKINGWATER TREATMENT PLANT PROJECT****Financing : Local Source****Latest State : 2016/539349** Registered Tender: Quoting 199.850.675,00 TL **MAPA İNŞAAT+YAPI VE YAPI** joint venture received the contract (DETAY-1526)**Tenderer : İZMİR METROPOLITAN MUNICIPALITY****Project : F. ALTAY-NARLIDERE KAYMAKAMLIK SUBWAY ROUTE STAGE 4 PROJECT****Financing : Local Source – EBRD Credit****Latest State :** The 7.2 km F.Altay-Narlıdere Subway Lines Tender was held on 9 Jan. 2018 (DETAY-1559) . The contestants are as follows:

- **INTEGRA CONSTRUCTION KZ LLP - LİMAK İNŞAAT SANAYİ ve TİC. A.Ş. - TAŞYAPI İNŞ. TAAH. SAN. VE TİC. A.Ş. ADI ORTAKLIĞI**
- **KOLİN İNŞAAT TUR. SAN. VE TİC. A.Ş.- SALINI IMPREGILO SPA JOINT VENTURE**
- **ALSİM ALARKO SAN. TİC. A.Ş.**
- **MAKYOL İNŞAAT SANAYİ TURİZM VE TİCARET A.Ş. - NUROL İNŞ. VE TİC. A.Ş. JOINT VENTURE**
- **ÖZKA İNŞAAT A.Ş. - YÜKSEL İNŞAAT A.Ş. - CTT STROYTRANSGAZ JOINT VENTURE**
- **ESTA CONSTRUCTION LTD ŞTİ. - CSCEC JOINT VENTURE**
- **DOĞUŞ İNŞAAT ve TİCARET A.Ş.**
- **YAPI MERKEZİ İNŞAAT ve SANAYİ A.Ş.**
- **DERE KONSTRÜKSİYON DEMİR İNŞAAT - CHINA MACHINERY ENGINEERING JOINT VENTURE**
- **BALLAST NEDOM INFRA B.Y.**
- **ÖZGÜN İNŞAAT TAAH. SANAYİ VE TİCARET LTD. ŞTİ. - CCCC LTD ŞTİ. JOINT VENTURE**
- **GÜLERMAK AĞIR SAN İNŞ ve TAAHHÜT A.Ş.F**
- **IC İÇTAŞ İNŞAAT SANAYİ VE TİC. A.Ş. - ASTALDI SPA JOINT VENTURE**
- **CENGİZ İNŞAAT SAN. VE TİC. A.Ş.**
- **NORINCO INTERNATIONAL COOPERATION LTD. - ÖZTAŞ İNŞ İNŞ. MALZEMELERİ TİC. A.Ş.**

Tenderer : KOCAELİ METROPOLITAN MUNICIPALITY**Project : SEKAPARK-PLAJYOLU ROUTE STAGE 2. TRAMWAY LINE PROJECT****Financing : Local Source****Latest State : 2017/574727** Registered Tender: Sekapark -Plajyolu Route 2nd Stage tramway lines (2,2 km Tram Lines) construction tender was held on 7 Dec. 2017 with 3 firms contesting. The lowest bid offer was 21.271.000,00 TL quoted by **EMRE RAY İNŞAAT.** (DETAY-1554)**Tenderer : STATE HIGHWAYS ADMINISTRATION (KGM)****Project : ANKARA-NİĞDE HIGHWAY PROJECT****Financing : BUILD-OPERATE-TRANSFER (BOT)****Latest State :** Ankara-Niğde Highway comprising 275 km highway and 55 KM connecting roads was tendered and contract was awarded to **ERG and SEZA İNŞAAT.** Its offer 11 years,10 months and 17 days including 3 year for construction. The proposed amount is 4.031.055.531 TL . (DETAY-1523)

Project : **MENEMEN-ALIAĞA-ÇANDARLI HIGHWAY PROJECT**
 Financing : BUILD-OPERATE-TRANSFER (BOT)
 Latest State : Menemen-Aliağa-Çandarlı Highway Project based on BOT model was tendered 15 Feb. 2017 with 6 offers. The best offer was 9 years 10 months 11 days including 3 years for construction, by **İC İÇTAŞ+ASTALDI+KALYON İNŞAAT JOINT VENTURE. (DETAY-1513)**

Project : **1915 ÇANAKKALE BRIDGE PROJECT**
 Financing : BUILD-OPERATE-TRANSFER (BOT)
 Latest State : Kınalı-Tekirdağ-Çanakkale-Savaştepe Highway Project Malkara-Çanakkale (1915 Çanakkale Bridge included) based on BOT model was tendered on 26 Jan. 2017. 4 firms submitted offers. The best offer was from **DAELİM (S.KOREA) + LIMAK+SK (S.KOREA) + YAPI MERKEZİ OGG** and it received the contract, quoting 10 bln 354 million 576.202 TL, with a period of 16 years 2 months 12 days including 5,5 years for construction . (DETAY-1510)

Tenderer : **HEALTH MINISTRY'S HEALTH INVESTMENTS GENERAL DIRECTORATE**
 Project : **MERSİN TARSUS 600 –BED STATE HOSPITAL PROJECT**
 Financing : Local Source
 Latest State : **2017/564142** Registered Tender: Mersin Tarsus District 600 -bed cap. State Hospital Project was tendered on 19 Dec. 2017 over an estimated cost of 187.525.447,71 TL and the lowest bid offer was 145.900.000,00 TL quoted by **SERVET ATAÇ-EVYAP. (DETAY-1556)**

Project : **BARTIN 400 –BED STATE HOSPITAL PROJECT**
 Latest State : **2017/557789** Registered Tender: Bartın Merkez 400 -bed cap. State Hospital Project was tendered on 12 Dec. 2017 Over an estimated cost of 195.342.234,73 TL and the lowest bid offer was 147.440.000,00 TL quoted by **ATR YAPI PROJE A.Ş.(DETAY-1555)**

Tenderer : **HEALTH MINISTRY-PUBLIC PRIVATE PARTNERSHIP DEPARTMENT**
 Project : **DIYARBAKIR KAYAPINAR CITY HOSPITAL PROJECT**
 Financing : Local Source -Public Private Partnership
 Latest State : Applications were received from 14 firms for Diyarbakır City Hospital Facilities on 5 Dec. 2017 for preselection. The Project covers 400 –bed cap.Women's Birth and Children Hospital, 150-bed cap. Pulmonology Hospital, 100-bed Cardiovascular Diseases Hospital and 100-bed Oncology Hospital totalling 750 bed capacity. as well as commercial service units. (DETAY-1554) Applicants are as follows:

- **AKFEN İNŞAAT + AKFEN HOLDİNG**
- **DİA INFRASTRUCTURE + KALYON İNŞAAT**
- **GAP İNŞAAT**
- **GÜRİŞ İNŞAAT**
- **PASİFİK GAYRİMENKUL + SİLA YATIRIM + KENT YAPI + TTT SAĞLIK**
- **SİYAH KALEM MÜHENDİSLİK + ÖZBURAK İNŞAAT + SANTEK İNŞAAT**
- **YDA İNŞAAT**
- **ALTINDAĞ İNŞ + İNTİM İNŞ + TEKNİK MEDİKAL**
- **ESTAT + TURUNÇ ATLASLAR + ESTA CONT.**
- **GÜRBAĞ İNŞAAT**
- **KAYI YATIRIM + KAYI İNŞAAT**
- **RÖNESANS SAĞLIK + RÖNASANS HOLDİNG**
- **TOYA GAYRİMENKUL + METAG İNŞAAT**
- **YILDIZLAR İNŞAAT + YILDIZLAR ELEKTRİK**

Project : **ANTALYA CITY HOSPITAL PROJECT**
 Financing : Local Source -Public Private Partnership
 Latest State : Applications were received from 18 firms for Antalya City Hospital Facilities on 21 Nov. 2017 for preselection. The Project covers 400 -bed cap. General Hospital, 100-bed cap. Cardiovascular Diseases Hospital, 100 bed cap. Oncology Hospital, 200-bed cap. Psychiatric Hospital, 50- bed cap. High Security Forensic Psychiatry Hospital and 150- bed cap. Physical Therapy and Rehabilitation Hospital, totalling1000 beds. as well as commercial service units.. (DETAY–1552). Applicants are as follows:

- **TEKFEN İNŞAAT VE TESİSAT A.Ş.**
- **YENİGÜN İNŞAAT+EMSAŞ İNŞAAT**
- **YDA İNŞAAT**
- **KAYI YATIRIM HOLDİNG+KAYI İNŞAAT**
- **GAP İNŞAAT**
- **ALSİM ALARKO**

- DIA İNŞAAT+KALYON İNŞAAT
- İLK İNŞAAT+ALTINDAĞ İNŞ.+TEKNİK MEDİKAL
- AKFEN İNŞAAT+AKFEN HOLDİNG
- RÖNESANS SAĞLIK YATIRIM+RÖNESANS HOL.
- ESTA İNŞAAT+TURUNÇ ATLAS TURİZM+ESTA CONSTRUCTION
- TOYA GAYRİMENKUL YATIRIM+METAG İNŞAAT
- PASİFİK İNŞAAT+SILA+KENT YAPI+TTT SAĞLIK HİZMETLERİ
- GÜRBAĞ İNŞAAT
- GAMA HOLDİNG+TÜRKERLER İNŞAAT
- SİYAH KALEM+ÖZBURAK+SANTEK
- GÜRİŞ İNŞAAT VE MÜHENDİSLİK A.Ş.
- YILDIZLAR İNŞAAT+YILDIZLAR ENERJİ

Project : **AYDINŞEHİR HOSPITAL PROJECT**

Financing : Local Source - Public Private Partnership

Latest State : Applications were received from 16 firms for Aydın City Hospital Facilities on 7 Nov. 2017 for preselection. The Project covers 800 –bed cap. general hospital and commercial service units. (DETAY-1550). Applicants are as follows:

- GAP İNŞ.
- TEKFEN İNŞ
- KAYI YATIRIM HOLDİNG+KAYI İNŞ.
- YDA İNŞ.
- ALSİM ALARKO
- SİYAH KALEM+ÖZBURAK+SANTEK
- DIA INFRASTRUCTURE YATIRIMLAR+KALYON İNŞ.
- GÜRİŞ İNŞ.
- RÖNESANS SAĞLIK+RÖNESANS HOLDİNG
- İLK İNŞ.+ALTINDAĞ İNŞ.+YEKNİKMED MEDİKAL
- AKFEN İNŞ.+AKFEN HOLDİNG
- TÜRKERLER+GAMA HOLDİNG
- GÜRBAĞ İNŞ.
- YILDIZLAR İNŞ.+YILDIZLAR ENERJİ
- EDA İNŞ.+TUNÇ ATLAS+ESTA CONSTRUCTION
- PASİFİK İNŞ.+SILA İNŞ.+HAVELSAN+KENT YAPI

Tenderer : **TURKISH ELECTRICITY TRANSMISSION CO. (TEİAŞ)**

Project : **ÜRGÜP 380 KV SUBSTATION PROJECT**

Financing : IBRD

Credit No : IBRD 83710-TR

Latest State : DB.ATT.26 Southeast European Energy assoc. (IBRD 83710-TR) Project covers 380/154/33 kV Ürgüp 380 Substation construction for which tender was held on 24 Oct. 2017. 5 proposals are being evaluated. The contract will cover 380/154/33 Ürgüp 380 Substation construction works, installation, testing, transportation, delivery, customs services and field storage, engineering and projecting services, supervision, commissioning and transfer of the Substation.

Scope: The contesting firms are : (DETAY-1548)

- **SEPCO 1 ELECTRIC POWER CONSTRUCTION CORPORATION**
Offer: 22.804.417,00 \$+31.402.186,00 TL
- **ABB ELEKTRİK SANAYİ, A.Ş.+ABB AB+GÜNGÖR ELEKTRİK KONSORSİYUMU**
Teklifi: 6.645.000,00 €+20.135.000,00 \$+51.400.000,00 SEK
Offer after Discount : 6.645.000,00 €+19.589.000,00 \$ +51.400.000,00 SEK
- **GRID SOLUTIONS ENERJİ ENDÜSTRİSİ+GRID SOLUTIONS SAS KONSORSİYUMU**
Offer: 15.360.223,00 € + 15.795.929,00 \$
- **BEST ELEKTRİK+MONTNETS RONGXİN TECHNOLOGY GROUP CO. KONSORSİYUMU**
Offer: 20.318.792,00 \$+8.005.197,00€
- **SIEMENS SANAYİ VE TİCARET A.Ş.+ SIEMENS AG KONSORSİYUMU**
Offer: 17.867.213,69 € + 11.420.921,13 \$

Project : **NATIONWIDE ENERGY LINES AERIAL MAINTENANCE SERVICES BY HELICOPTER**

Financing : Local Source

Latest State : **2017/524892** Registered Tender: 154 kV and 400 kV energy transmission lines aerial maintenance services will take place for 1095 days, for which tender was held on 6 Dec. 2017. Over an estimated cost of 70.537.717,50 TL, 3 firms submitted bids. The lowest bid offer was 67.948.000,00 TL, quoted by **BAŞARI TİCARET** (DETAY-1554)

- Project : **REF. H 380 ENERGY LINES PROJECT**
Financing : Local Source
Latest State : **2017/577182** Registered Tender: Ref. H.384 380 kv (224 km) 3B 1272 MCM Conductor Reşadiye-Yozgat 380 TM energy transmission lines tender was held on 27 Dec. 2017. Over an estimated cost of 129.762.466,25 TL, and limit value of 95.194.118,60 TL, 4 firms submitted bids. The lowest bid offer was 95.792.297,00 TL quoted by **ŞA-RA ENERJİ. (DETAY-1557)**
- Project : **KAVACIK GIS TM UNDERGROUND POWER CABLING PROJECT**
Financing : Local Source
Latest State : **2017/487675** Registered Tender: Ref. TKABÇY.9, Kavacık GIS TM – Vaniköy İnterface N 380 kV, 2*2000 mm² XLPE İnsulated Underground Power cabling connection project tender was held on 10 Nov. 2017. Over an estimated cost of 71.215.363,70 TL , 2 firms submitted bids. The lowest bid offer 86.600.000,00 TL quoted by **DEMİRER KABLO TESİSLERİ + EMTA ENERJİ (DETAY-1551)**
- Project : **KARTAL GIS TM-İÇMELER TM II UNDERGROUND POWER CABLING YAPIM PROJECT**
Financing : Local Source
Latest State : **2017/430682** Registered Tender: Ref. TKABY.49, Kartal GIS TM – İçmeler TM II 154 Kv, 1600 mm² XLPE insulated Underground power cabling project tender was held on 17 Oct. 2017, and 3 firms submitted bids over an estimated cost of 36.638.848,45 TL .The lowest bid offer was 37.249.325,00 TL, quoted by **ZRD MÜHENDİSLİK. (DETAY-1547).**
- Project : **SAMSUN-BAFRA REF. H.655 ENERGY LINES CONSTRUCTION PROJECT**
Financing : Local Source
Latest State : **2017/502991** Registered Tender: Ref. H.655 154 kV (~50,5 km) 1272 MCM conductor Samsun 1 - 19 Mayıs - Bafra (renewal) ETL and 154 kV (~21,0 km) 1272 conductor Yenidere – (Erbaa - Yaprak HES) Branching point energy lines construction tender was held on 15 Nov. 2017. Over an estimated cost of 23.343.515 TL, the lowest bid offer of 19.653.000 TL, was submitted by **ENER -BA ENERJİ.(DETAY-1551)**
- Project : **ELMALI-FETHİYE REF.H.647 ENERGY LINES CONSTRUCTION PROJECT**
Financing : Local Source
Latest State : **2017/408650** Registered Tender: Ref.H.647 (~85 km) 154 kV 1272 MCM Conductor Elmalı – Fethiye ETL construction tender was held on 25 Sep. 2017. Over an estimated cost of 20.014.957,50 TL, the lowest bid offer was 17.946.000,00 TL submitted by **KAR-PA ELEKTRİK. (DETAY-1544)**
- Project : **REF. TKABY 44 SEYHAN TM BRŞ N NORTH ADANA GIS UNDERGROUND POWER CABLING PROJECT**
Financing : IBRD
Latest State : **2017/213794** Registered Tender: For Ref. TKABY. 44, Seyhan TM BRŞ N–North Adana GIS TM 154 Kv, 2x1000mm² XLPE İnsulated Underground Power Cabling Project , the tender was held on 31 May 2017 and quoting 15.834.000,00 TL, **EMTA ENERJİ A.Ş.** received the contract **(DETAY-1528)**
- Project : **ÇAN HAVZA SUBSTATION PROJECT**
Financing : IBRD
Latest State : For 380/154/33 kV Çan 380 Havza substation, the tender was held on 29 May 2017. 8 submitted offers. The lowest bid offer 11.633.000 Euro was submitted by **AVNİ ULUTAŞ. (DETAY-1528)**
- Project : **154 KV KARABAĞLAR TM AND BUCA TM UNDERGROUND POWER CABLING PROJECT**
Financing : IBRD
Latest State : For Ref. DB. KAB.13 154 kV Karabağlar Substation–Buca Substation Underground XLPE Power Cabling Project, the tender was held on 18 Apr. 2017. 4 firms submitted offers.. **(DETAY-1522)**
- Project : **BURSA EAST İTM 215, 380 KV GAS INSULATED MT PROJECT**
Latest State : **2017/85560** Registered Tender: For Ref. İTM.215, 380 kV Bursa East 380 Gas İnsulated Substation Project, bids were received on 10 Apr. 2017. Over an estimated cost of 81.300.548,46 TL , the contract was awarded to **GRID SOLUTIONS ENERJİ** quoting **58.984.320,50 TL (DETAY-1521)**
- Project : **TAŞOLUK İTM 217, 380 KV GAS INSULATED MT PROJECT**
Financing : Local Source
Latest State : **2017/86155** Registered Tender: For Ref. İTM.217, 380 kV Taşoluk 380 Gas İnsulated Substation Project, bids were received on 11 Apr. 2017. Over an estimated cost of 52.279.752,03 TL, the contract was awarded to **GÜNGÖR ELEKTRİK** quoting 42.727.000,00 TL **(DETAY-1521)**

Project : **İTM 20, 380 KV KÖSE TM PROJECT**
Financing : Local Source
Latest State : **2016/608032** Registered Tender: For Ref. İTM.210, 380 Kv Köse (Gümüşhane) 380 Substation (Dokap) bids were received on 7 March 2017 over an estimated cost of 57.166.023,11 TL. QUoting 48.994.108,00 TL **ASEM GRUP** received the contract (**DETAY-1516**)

Project : **ATIŞALANI TM-SAĞMALCILAR GIS TM UNDERGROUND POWER CABLING PROJECT**
Financing : IBRD
Latest State : **2016/611055** Registered Tender: For Ref. TKABÇY.5, Atışalani TM-Sağmalcılar GIS TM 380 kV, 2000 mm² + 154 kV, 1000 mm² XLPE İnsulated Underground Power Cabling Project, bids were received on 16 Feb. 2017 . 3 firms submitted offers over an estimated cost of 28.397.617,34 TL . Quoting 27.734.500,00 TL, **DEMİREK KABLO** received the contract.(**DETAY-1513**)

Project : **ENERGY TRANSMISSION LINE CONSTRUCTIONS AND CONNECTING LINES IN VARIOUS LOCATIONS**

- **Ref. TKABÇY.6.** Sağmalcılar GIS TM – Çağlayan GIS TM 380 Kv, 2000 Mm² XLPE Insulated Underground Power Cable Connecting Project
Tender reg.no : **2017/268721**
Bid deadline : 07.07.2017
Winner : **BTE ENERJİ++ZRD MÜH.**
Approx. Cost : 62.594.107,55 TL
Contract cost : 46.947.285,00 TL
- **Ref. TKABY.40.** Görükle TM-Bursa Sanayi TM 154 Kv, 1600mm² XLPE Insulated Underground Power Cable Connecting Project
Tender reg.no : **2017/112464**
Bid deadline : 20.04.2017
Winner : **EMTA ENERJİ A.Ş**
Approx. Cost : 8.960.875,77 TL
Contract cost : 7.874.630,00 TL
- **Ref. TKABY.41.** Bursa Sanayi TM – Beşevler TM 154 Kv, 1600mm² XLPE Insulated Underground Power Cable Connecting Project
Tender reg.no : **2017/85450**
Bid deadline : 23.03.2017
Winner : **EMTA ENERJİ İNŞ.**
Approx. Cost : 13.706.771,37 TL
Contract cost : 13.374.000,00 TL
- **Ref. TKABY.46.** Ümraniye GIS TM - Küçükbakkalköy GIS TM 154 Kv, 1600 Mm² XLPE Insulated Underground Power Cable Connecting Project
Bid method : Auction
Tender reg.no : **2017/153908**
Bid deadline : 07.04.2017
Winner : **EMTA ENERJİ İNŞ.**
Approx. Cost : 22.232.163,09 TL
Contract cost : 21.244.000,00 TL
- **Ref. TKABY.48** Bahribaba GIS TM – Hilal GIS TM 154 Kv, 1600mm² XLPE Insulated Underground Power Cable Connecting Project
Tender reg.no : **2017/325801**
Bid deadline : 04.08.2017
Winner : **ZRD MÜHENDİSLİK A.Ş**
Approx. Cost : 19.896.643,23 TL
Contract cost : 16.245.525,00 TL
- **Ref. İTM.247** 154 Kv Çanakkale Havza-1 Substation Project
Tender reg.no : **2017/382250**
Bid deadline : 07.09.2017
Winner : **YENİ BAŞKENT+AKGÜN LTD**
Approx. Cost : 12.494.696,88 TL
Contract cost : 10.880.000,00 TL
- **Ref. İTM.243** 154 Kv Düzce OSB Substation Project
Tender reg.no : **2017/323292**
Bid deadline : 04.08.2017
Winner : **MARDİVA İNŞAAT**
Approx. Cost : 14.838.975,37 TL
Contract cost : 12.340.000,00 TL
- **Ref. İTM.255,** 1 ea 380 Kv and 1 ea 154 Kv Substation Project
Tender reg.no : **2017/459790**
Bid deadline : 18.10.2017
Winner : **GİRİŞİM ELEKTRİK**
Approx. Cost : 17.086.921,67 TL
Value Acc.to Contr. : 12.636.653,70 TL
Contract cost : 11.409.143,00 TL
- **Ref. İTM.240** 2 Adet 154 Kv Substation Project
Tender reg.no : **2017/273140**
Bid deadline : 14.07.2017
Winner : **SELÇUK ALBAYRAK**
Approx. Cost : 17.823.719,26 TL
Value Acc.to Contr. : 2.260.455,75 TL
Contract cost : 2.091.720,00 TL
- **Ref. İTM.246** 380 Kv Yozgat 380 TM (KOP) (New)
Tender reg.no : **2017/357810**
Bid deadline : 06.09.2017
Winner : **AVNİ ULUTAŞ**
Approx. Cost : 53.989.274,14 TL
Contract cost : 40.413.000,00 TL
- **Ref. İTM.250** 154 Kv Eleşkirt TM (DAP) (New) constr.
Tender reg.no : **2017/411174**
Bid deadline : 15.09.2017
Winner : **SELÇUK BAY+DAB İNŞ.**
Approx. Cost : 11.675.182,94 TL
Contract cost : 9.654.000,00 TL
- **Ref. İTM.251** 154 Kv Adatoprakpınar TM
Tender reg.no : **2017/422909**
Bid deadline : 04.10.2017
Winner : **GİRİŞİM ELEKTRİK A.Ş**
Approx. Cost : 13.101.326,21 TL
Contract cost : 11.127.383,00 TL
- **Ref. İTM.252** 154 Kv Ferizli OSB TM (New)
Tender reg.no : **2017/422302**
Bid deadline : 04.10.2017
Winner : **DATL TELLİOĞLU LTD**
Approx. Cost : 15.725.683,82 TL
Contract cost : 12.785.000,00 TL

- **Ref. İTM.221, 154 Kv Samsun-2 TM Renewal (YHGP)**
Tender reg.no : **2017/167596**
Bid deadline : 05.05.2017
Winner : **MARDİVA İNŞAAT**
Approx. Cost : 13.706.771,37 TL
Contract cost : 10.765.000,00 TL
- **Ref. İTM.228, 2 ea 380 Kv Substation Project**
Tender reg.no : **2017/178624**
Bid deadline : 12.05.2017
Winner : **BEST ELEKTRİK A.Ş**
Approx. Cost : 15.671.296,64 TL
Value Acc.to Contr. : 5.583.744,87 TL
Contract cost : 5.410.000,00 TL
- **Ref. İTM.228, 2 ea 380 Kv Substation Project**
Tender reg.no : **2017/178624**
Bid deadline : 12.05.2017
Winner : **BEST ELEKTRİK A.Ş**
Approx. Cost : 15.671.296,64 TL
Value Acc.to Contr. : 5.583.744,87 TL
Contract cost : 5.410.000,00 TL
- **Ref. İTM.228, 2 ea 380 Kv Substation Project**
Tender reg.no : **2017/178624**
Bid deadline : 12.05.2017
Winner : **BEST ELEKTRİK A.Ş**
Approx. Cost : 15.671.296,64 TL
Value Acc.to Contr. : 10.087.551,77 TL
Contract cost : 9.380.000,00 TL
- **Ref. İTM.218, 380 Kv Kavacık Gas Insulated Substation**
Tender reg.no : **2017/89821**
Bid deadline : 14.04.2017
Winner : **GRID SOLUTIONS A.Ş**
Approx. Cost : 79.139.186,80 TL
Contract cost : 58.378.947,00 TL
- **Ref. İTM.214 154 kv Akköprü Gas Insulated SUBSTATION**
Tender reg.no : **2017/145232**
Bid deadline : 15.05.2017
Winner : **ANADOLU ELEKTRİK A.Ş**
Approx. Cost : 32.264.943,76 TL
Contract cost : 28.987.000,00 TL
- **154 Kv Aksaray GIS TM Constr.**
Tender reg.no : **2017/613375**
Bid deadline : 15.02.2017
Winner : **GENSER GENEL MÜH.**
Approx. Cost : 32.647.598,07 TL
Contract cost : 28.570.000,00 TL
- **Ref. İTM.212, 380 Kv Atışalanı TM Expansion Constr.**
Tender reg.no : **2017/561953**
Bid deadline : 19.01.2017
Winner : **BEST ELEKTİRİK A.Ş**
Approx. Cost : 13.165.646,24 TL
Contract cost : 13.362.000,00 TL
- **Ref. İTM.209, 1 ea 154 Kv Substation Project**
Tender reg.no : **2017/578482**
Bid deadline : 24.01.2017
Winner : **MHY ELEKTRİK LTD.**
Approx. Cost : 13.748.467,10 TL
Value Acc.to Contr. : 12.196.250,11 TL
Contract cost : 10.978.375,35 TL
- **Ref. İTM.248, 154 Kv Merzifon Substation Project**
Tender reg.no : **2017/363391**
Bid deadline : 22.08.2017
Approx. Cost : 18.592.687,86 TL
Bedeli : 15.975.670,00TL
Yüklenici : **AYDURAN ELEKT. LTD.**
- **Ref. İTM.242 154 Kv Hotamış TM (KOP)**
Tender reg.no : **2017/323907**
Bid deadline : 08.08.2017
Winner : **MAT ENERJİ-ARSTEK İNŞ.**
Approx. Cost : 12.780.463,62 TL
Contract cost : 14.980.064,40 TL
- **Ref. İTM.230.154 kv Dumlupınar Gas Insulated Substation**
Tender reg.no : **2017/235861**
Bid deadline : 16.06.2017
Winner : **SA-RA ENERJİ A.Ş**
Approx. Cost : 29.208.776,75 TL
Contract cost : 24.544.000,00 TL
- **Ref. İTM.244 154 kv Hasanağa Substation Project**
Tender reg.no : **2017/326024**
Bid deadline : 03.08.2017
Winner : **MEMSAN ENERJİ A.Ş**
Approx. Cost : 17.208.608,25 TL
Contract cost : 13.649.500,00 TL
- **Ref. İTM.245 154 Kv Akyaka Substation Project**
Tender reg.no : **2017/345643**
Bid deadline : 11.08.2017
Approx. Cost : 13.941.089,52 TL
Contract cost : 11.848.203,00TL
Winner : **AYDURAN ELEKT. LTD.**
- **Ref. İTM.249, 154 Kv Çine Substation Project**
Tender reg.no : **2017/411248**
Bid deadline : 15.09.2017
Approx. Cost : 16.828.071,89 TL
Bedeli : 13.327.000,00TL
Winner : **İNEMKO İNŞ. LTD.**
- **Ref. TKABY.45 Bornova 380 GIS TM BRŞ N – Piyale GIS TM 154 Kv, 1600MM² XLPE Insulated Underground Power Cable Connecting Project**
Tender reg.no : **2017/197481**
Bid deadline : 25.05.2017
Winner : **ZRD MÜHENDİSLİK A.Ş**
Approx. Cost : 18.446.089,36 TL
Contract cost : 14.473.900,00 TL
- **Ref. TKABY.44 Seyhan TM BRŞ N – Kuzey Adana GIS TM 154 Kv, 2X1000MM² XLPE Insulated Underground Power Cable Connecting Project**
Tender reg.no : **2017/213794**
Bid deadline : 31.05.2017
Winner : **EMTA ENERJİ A.Ş**
Approx. Cost : 22.249.152,45 TL
Contract cost : 15.834.000,00 TL
- **Ref. TKABY.47 Ambarlı TM-Sultanmurat GIS TM 154 kv 2x1600 nn2 XLPE Insulated Underground Power Cable Connecting Project**
Tender reg.no : **2017/235663**
Bid deadline : 21.06.2017
Winner : **TÜRK PRYSMIAN KABLOVE SİST**
Approx. Cost : 74.812.594,74 TL
Contract cost : 55.079.549,00 TL

- Tenderer : **STATE RAILWAYS AUTHORITY (TCDD)**
Project : **KAYAŞ-YERKÖY YHT SUPERSTRUCTURE AND ELECTROMECHANICAL WORKS PROJECT**
Financing : Local source
Latest State : **2017/72552** Registered Tender: Bids were collected on 22 may 2017 over an estimated cost of 1.109.719.156,88 TL and limit value of 813.022.385,52 TL for the Kayaş-Yerköy High Speed Train Project superstructure and electromechanical works. The lowest bid offer was 767.530.540,23 TL submitted by **ATARAY MİMARLIK + SÖĞÜT İNŞAAT + TUĞRA MAKİNA + YDA İNŞAAT + İNTAŞ İNŞAAT + TEYDA İNŞAAT .. (DETAY-1527)**
- Project : **BAŞPINAR-GAZİANTEP-M YAVUZ STATIONS ROUTE INFRASTRUCTURE AND SUPERSTRUCTURE (GAZIRAY) PROJECT**
Financing : Local source
Latest State : **2014/94814** Registered Tender: For the Başpınar – Gaziantep -Mustafa Yavuz Substations route reconstruction infrastructure and superstructure works (Gaziray) , the contract was awarded to **GÜLERMAK+KOLİN+ KALYON İNŞAAT** quoting 429.758.827,67 TL.(DETAY-1511)
- Tenderer : **MASS HOUSING ADMINISTRATION (TOKİ)**
Project : **KARABÜK 1444 HOUSES AND SOCIAL FACILITIES PROJECT**
Financing : Local source
Latest State : **2017/580739** Registered Tender: For Karabük Prov.'s Merkez Distr. Belen Mahallesi 1144 ea houses, 1 ea mosque, 1 ea trade centre, 1 ea social facilities, and infrastructure and landscape works, bids were received on 20 Dec. 2017. Over an estimated cost of 215.684.455,86 TL and limit value of 163.134.507,04 TL the lowest bid offer of 169.100.000,00 TL was submitted by **ESTA+İNTEK İNŞAAT . (DETAY-1556)**
- Project : **KONYA EREĞLİ OSMANİYE DISTRICT 334 HOUSES AND SOCIAL FACILITIES PROJECT**
Financing : Local source
Latest State : **2017/507961** Registered Tender: For 334 ea houses, 1 ea 4 –shop cap. shopping centre and 1 ea mosque, and infrastructure and landscape works, bids were received on 14 Nov. 2017. Over an estimated cost of 53.787.118,80 TL the lowest bid offer of 40.562.000,00 TL was submitted by **MERKEZ YAPI+BİSER İNŞAAT (DETAY-1551)**
- Project : **ANKARA-SİNCAN DISTRICT SARAYCIK 2. REGION STAGE 1 1000 EA HOUSES AND SOCIAL FACILITIES PROJECT**
Financing : Local Source
Latest State : **2017/419046** Registered Tender: For Region 2 , Stage 1: 1000 ea houses, 2 ea trade centre, 1 ea mescit and 1 ea car park, and infrastructure and landscape works, bids were received on 26 Sep. 2017. Over an estimated cost of 178.233.815,08 TL the lowest bid offer of 129.350.000,00 TL was submitted by **AKAY İNŞAAT . (DETAY-1544)**
- Project : **NEVŞEHİR-GÖRE HOUSES AND SOCIAL FACILITIES PROJECT**
Financing : Local Source
Latest State : **2017/424186** Registered Tender: For 225 Ea houses , 1 ea 3 –shop cap. trade centre and infrastructure and landscape works, bids were received on 26 Sep. 2017. Over an estimated cost of 39.586.275,00 TL the lowest bid offer of 29.552.000,00 TL was submitted by **KBN İNŞAAT . (DETAY-1544)**
- Project : **TOKAT-ZİLE 437 EA HOUSES AND SOCIAL FACILITIES PROJECT**
Financing : Local Source
Latest State : **2017/396847** Registered Tender: For 437ea houses , 1 ea 3 -shop cap. trade centre, infrastructure and landscape works, bids were received on 11 Sep. 2017. Over an estimated cost of 59.903.490,68 TL the lowest bid offer of 44.798.000,00 TL was submitted by **POLEN İNŞAAT . (DETAY-1542)**
- Project : **GAZİANTEP ISLAHİYE FEVZİPAŞA MAHALLESİ HOUSES AND SOCIAL FACILITIES PROJECT**
Financing : Local Source
Latest State : **2017/389399** Registered Tender: For Stage 3.; 596 ea houses,1 ea 5 -shop cap. trade centre,1 ea mosque,1 ea 16 – class school and infrastructure and landscape works, bids were received on 6 Sep. 2017. Over an estimated cost of 110.170.014,79 TL the lowest bid offer of 88.440.000,00 TL was submitted by **KAHRAMAN İNŞAAT . (DETAY-1541)**
- Project : **ERZİNCAN-ÜZÜMLÜ HOUSES AND SOCIAL FACILITIES PROJECT**
Financing : Local Source
Latest State : **2017/387440** Registered Tender: For 363 ea tarımköy houses,T4-A trade centre and infrastructure and landscape works bids were received on 6 Sep. 2017. Over an estimated cost of 88.730.116,42 TL the lowest bid offer of 66.150.000,00 TL was submitted by **YAPI-TEK+ŞAHİNLER . (DETAY-1541)**

- Project : **İSTANBUL BAŞAKŞEHİR KAYABAŞI KAYAPARK INFRASTRUCTURE PROJECT**
Financing : Local Source
Latest State : **2017/234622** Registered Tender: For İstanbul Prov.'s Başakşehir Distr. Kayabaşı Mevkii Kayapark 1.stage recreational area arrangements, bids were received on 7 Sep. 2017. Over an estimated cost of 55.186.167,98 TL the lowest bid offer of 47.800.000,00 was submitted by **EGECAN AKARYAKIT + ASİL İNŞ (DETAY-1541)**
- Project : **İSTANBUL BAŞAKŞEHİR KAYAŞEHİR 399 HOUSES AND SOCIAL FACILITIES PROJECT**
Financing : Local Source
Latest State : Bids were received on 12 June 2017 and submitting an offer of 73.650.000,00 TL, **EVYAP İNŞAAT** received the contract (**DETAY-1533**)
- Project : **MANİSA YUNUSEMRE 2. STAGE 775 HOUSES AND SOCIAL FACILITIES PROJECT**
Financing : Local Source
Latest State : Bids were received on 3 Aug. 2017 and submitting an offer of 148.790.000,00 TL, **ALBA İNŞAAT** received the contract.(**DETAY-1538**)
- Project : **KIRKLARELİ MERKEZ HAMİDİYE 535 HOUSES AND SOCIAL FACILITIES PROJECT**
Financing : Local Source
Latest State : 2017/336163 Registered Tender: Bids were received on 7 Aug. 2017 over an estimated cost of 85.079.202,86 TL and submitting an offer of 65.970.000,00 TL, **SERVET ATAC-ATAÇLAR İNŞ.** received the contract (**DETAY-1538**)
- Project : **BURSA GEMLİK CİHATLI 224 HOUSES AND SOCIAL FACILITIES PROJECT**
Financing : Local Source
Latest State : Bids were received on 27 July 2017, and submitting an offer of 41.682.000,00 TL, **ABDURRAHMAN ATAÇ** received the contract (**DETAY-1538**)
- Project : **GAZİANTEP ISLAHİYE FEVZİPAŞA 3. STAGE 596 HOUSES AND SOCIAL FACILITIES PROJECT**
Financing : Local Source
Latest State : Bids were received on 26 July 2017 and submitting an offer of 88.228.000,00 TL, **ALİ ACAR İNŞAAT LTD ŞTİ** received the contract (**DETAY-1538**)
- Project : **ŞIRNAK-MERKEZ 4. REGION 1. STAGE 708 HOUSES AND SOCIAL FACILITIES PROJECT**
Financing : Local Source
Latest State : Bids were received on 24 July 2017 and submitting an offer of 101.300.000,00 TL, **ACER+K.SAVAŞ GÜLŞEN** received the contract (**DETAY-1538**)
- Project : **ŞIRNAK-MERKEZ 4. REGION 2. STAGE 986 HOUSES AND SOCIAL FACILITIES PROJECT**
Financing : Local Source
Latest State : Bids were received on 24 July 2017 and submitting an offer of 134.880.000,00 TL, **CABA İNŞAAT** received the contract (**DETAY-1538**)
- Project : **ANKARA-SİNCAN SARAYCIK GECEKONU PREVENTION PROJECT**
Financing : Local Source
Latest State : Bids were received on 24 July 2017 and offering 134.880.000,00 TL, **CABA İNŞAAT** received the contract (**DETAY-1538**)
- Project : **ANKARA-SİNCAN SARAYCIK GECEKONU PREVENTION PROJECT**
Financing : Local Source
Latest State : Bids were received on 31 July 2017, and offering 99.312.000,00 TL **ÜÇEL ENERJİ+AKKOL MÜD.** received the contract (**DETAY-1538**)
- Project : **ANKARA-SİNCAN SARAYCIK 2.REGION 2. STAGE 891 HOUSES AND SOCIAL FACILITIES PROJECT**
Financing : Local Source
Latest State : Bids were received on 15 May 2017 and offering 118.844.000,00 TL **GÖÇAR İNŞAAT A.Ş.** received the contract (**DETAY-1533**)
- Project : **HATAY YAYLADAĞI DAĞARDI KAYAPINAR AND ALTINÖZÜ BORDER SECURITY SYSTEM ADDITIONAL STRUCTURES**
Financing : Local Source
Latest State : Bids were received on 20 July 2017 and offering 32.320.000,00 TL **İNTAŞ İNŞAAT A.Ş.** received the contract (**DETAY-1538**)
- Project : **ŞIRNAK-MERKEZ 3. REGION 728 HOUSES AND SOCIAL FACILITIES PROJECT**
Latest State : Bids were received on 13 July 2017 and offering 109.678.047,00 TL **TEFİROM İNŞAAT** received the contract (**DETAY-1538**)

Project : **SİVAS MERKEZ 762 HOUSES AND SOCIAL FACILITIES PROJECT**
Financing : Local Source
Latest State : Quoting 84.700.000,00 TL, **LEDA YAPI** received the contract (**DETAY-1533**)

Project : **VAN-ERCİŞ 407 EA SHOPS AND 48 EA OFFICES CONSTRUCTION PROJECT**
Financing : Local Source
Latest State : The tender was held on 12 June 2017 and submitting an offer of 54.635.000,00 TL, **YCG İNŞAAT** received the contract (**DETAY-1533**)

Project : **AFYONKARAHİSAR DİNAR İNCİRLİ MAHALLESİ 3. STAGE 800 HOUSES AND SOCIAL FACILITIES PROJECT PROJECT**
Latest State : The tender was held on 12 June 2017 and submitting an offer of 98.700.000,00 TL, **ÖZKILIÇ İNŞAAT** received the contract (**DETAY-1533**)

Project : **MARDİN 8 AND 11. STAGES HOUSING PROJECT**
Financing : Local source
Latest State : The tender was held on 24 May 2017 and submitting an offer of 176.653.000,00TL **MUSTAFA EKŞİ** received the contract (**DETAY-1533**)

Project : **MARDİN NUSAYBİN 10.STAGE 535 HOUSES AND SOCIAL FACILITIES PROJECT**
Financing : Local Source
Latest State : The tender was held on 17 May 2017 and submitting an offer of 87.053.000,00 TL **MUSTAFA EKŞİ** received the contract (**DETAY-1533**)

Project : **MARDİN NUSAYBİN 4. STAGE 342 HOUSES AND SOCIAL FACILITIES PROJECT**
Financing : Local Source
Latest State : The tender was held on 12 May 2017 and submitting an offer of 94.800.000,00 TL, **LEDA YAPI** received the contract (**DETAY-1533**)

Project : **MARDİN NUSAYBİN 5. STAGE 353 , 6. STAGE 433 HOUSES AND SOCIAL FACILITIES PROJECT**
Financing : Local Source
Latest State : The tender was held on 23 May 2017 and submitting an offer of 148.000.000,00TL, **MERCAN İNŞAAT** received the contract (**DETAY-1533**)

Project : **ARTVİN YUSUFELİ 3. REGION 334 HOUSES AND SOCIAL FACILITIES PROJECT**
Financing : Local Source
Latest State : The tender was held on 13 June 2017 and submitting an offer of 109.122.000,00TL **MAKSEM YAPI ÖZÜLKE İNŞAAT** received the contract (**DETAY-1533**)

Project : **BATMAN HASANKEYF 390 HOUSES AND SOCIAL FACILITIES PROJECT**
Financing : Local Source
Latest State : **2017/48985** Registered Tender: The tender was held on 14 Feb. 2017 and submitting an offer of 94.347.000,00 TL, **KAYAŞ MAD.SERTKA MÜH.** received the contract (**DETAY-1533**)

Project : **HAKKARİ YÜKSEKOVA 1. REGION 2. STAGE 768 HOUSES AND SOCIAL FACILITIES PROJECT**
Financing : Local Source
Latest State : The tender was held on 1 Feb. 2017 and submitting an offer of 118.735.000,00 TL, **POLEN İNŞ.+DİBAY İNŞ.** received the contract (**DETAY-1533**)

Project : **ŞIRNAK ÇİZRE 4. STAGE 885 HOUSES AND SOCIAL FACILITIES PROJECT**
Financing : Local Source
Latest State : The tender was held on 5 Jan. 2017 and submitting an offer of 136.675.000,00 TL, **CABA İNŞAAT** received the contract (**DETAY-1533**)

Project : **ŞIRNAK ÇİZRE 3. STAGE 631 HOUSES AND SOCIAL FACILITIES PROJECT**
Financing : Local Source
Latest State : The tender was held on 5 Jan. 2017 and submitting an offer of 128.700.000,00 TL, **MUSTAFA EKŞİ+BİSER İNŞ** received the contract (**DETAY-1533**)

CONSULTANCY & SURVEY PROJECTS

INFRASTRUCTURE INVESTMENTS GENERAL DIRECTORATE (MINISTRY OF TRANSPORT, MARITIME & COMMUNICATIONS)

- Project Name:** **KARAMAN AIRPORT SUPERSTRUCTURE PROJECT & TENDER DOCUMENTATION (PİD)**
Financing: Local source
Latest State : Under File No **2017/202568** The tender was held for Karaman Airport superstructure project and tender documentation services (PİD) (17.000 m3). Price envelopes were received on 20 Nov. 2017. With an approx. cost of 2.084.400,00 TL the lowest bid price was submitted by **TÜMAŞ MÜHENDİSLİK** as 94,43% score and 1.245.000 TL.. (**DETAY-1552**)
- Project Name:** **YOZGAT AIRPORT SUPERSTRUCTURE PROJECT & TENDER DOCUMENTATION (PİD)**
Financing: Local source
Latest State : **2017/215319** The tender was held for Yozgat Airport superstructure project and tender documentation services (PİD) (19.000 m3) . Price envelopes were received on 20 Nov. 2017. With an approx. cost of 2.060.666,67 TL the lowest bid price was submitted by **TÜMAŞ MÜHENDİSLİK** as 93,47 % tech. score and 945.000 TL. (**DETAY-1552**)
- Project Name:** **FILYOS PORT AND FILYOS INDUSTRIAL ZONE RAIL CONNECTION PROJECT**
Financing: Local source
Latest State : Under File No **2017/414359** The tender was held for Filyos Port and Filyos İndustrial Zone Railway Connection (with land road connection) survey Project services, feasibility, ÇED services . Eligible firms submitted their Price envelopes on 14 Nov. 2017. (**DETAY-1551**)
- Project Name:** **ÇUKUROVA REGION AND İSKENDERUN BAY INDUSTRIAL FACILITIES RAIL CONNECTION PROJECT**
Financing: Local source
Latest State : Under File No **2017/531699** The tender was held for Çukurova Region and İskenderun Bay Industrial Facilities - Yumurtalık Free Zone İndustrial Facilities and Ports Railway Connection (40 km) survey Project services, feasibility, ÇED services. Eligible firms submitted their price envelopes on 15 Nov. 2017 (**DETAY-1551**)
- Project Name:** **YENİKAPI CRUISER PORT PROJECT**
Financing: Local source
Latest State : Under File No **2017/402699** The tender was held for Yenikapı Cruiser Port Survey and Consultancy. Eligible firms submitted their price envelopes on 14 Nov. 2017. (**DETAY-1551**)
- Project Name:** **RİZE ARTVİN AIRPORT SUPERSTRUCTURE & TENDER DOCUMENTATION (PİD)**
Financing: Local source
Latest State : Under File No **2017/76007** The tender was held for Rize-Artvin Airport superstructure and tender documentation services (PİD) and quoting 1.300.000,00 TL the contract was awarded to **N.K.Y. MİMARLIK**. (**DETAY-1547**)
- Project Name:** **3-LEVEL BIG İSTANBUL TUNNEL PROJECT**
Financing: BUILD-OPERATE-TRANSFER (BOT)
Latest State : Under File No **2016/468276** The tender was held on 5 April 2017 for 3-Level Big İstanbul Tunnel consultancy and survey services, engineering, and quoting 28.835.000,00 TL the contract was awarded to **YÜKSEL PROJE A.Ş.**. (**DETAY-1527**)
- Project Name:** **ANKARA-KEÇİÖREN KUYUBAŞI STATION - YHT STATION ROUTE RAIL SYSTEM PROJECT**
Financing: Local Source
Latest State : Under File No **2016/530926** The tender was held for Ankara Keçiören Kuyubaşı Station-YHT Gar Station rail system connection survey services, engineering, (11 km) and quoting 2.794.000,00 TL the contract was awarded to **ALTINOK MÜŞ. MÜH. A.Ş.**. (**DETAY-1523**)

JUSTICE MINISTRY

- Project Name:** **VARIOUS PENITENTIARY FACILITIES**
Financing: Local source
Latest State : Under File No **2017/480987** The tender was held for Sungurlu Penitentiary Institution building control and consultancy services : Eligible firms were invited to submit their offers on 08.01.2018. (**DETAY-1548**)

Latest State : Under File No **2017/484428** The tender was held for Erzincan Penitentiary Institution building control and consultancy services . Applications were received on 23 Oct. 2017 but the tender canceled. (**DETAY-1548**)

Latest State : Under File No **2017/486551** The tender was held for Sakarya Penitentiary Institution building control and consultancy services . Eligible firms were invited to submit their offers on 11.01.2018. (**DETAY-1548**)

Latest State : Under File No **2017/487298** The tender was held for Antalya Elmalı Penitentiary Institution building control and consultancy services . Eligible firms were invited to submit their offers on 09.01.2018. (**DETAY-1548**)

Latest State : Under File No **2017/495226** The tender was held for Bitlis Ahlat Penitentiary Institution building control and consultancy services . Eligible firms were invited to submit their offers on 11.01.2018. (**DETAY-1552**)

Management : **PETROLEUM PIPELINES CO. (BOTAŞ)**

Project Name: **TURKSTREAM DGBH MAIN METERING STATION PROJECT**

Financing: Local source

Latest State : Under File No **2017/527087** The tender was held for Turk Stream N.Gas pipelines main metering station engineering services on 15 Nov. 2017. With an approx. cost of 661.568 TL , 4 firms submitted bids and the lowest bid price of 672.000 TL came from **TÜM MÜHENDİSLİK**.

Project Name: **BATMAN-DÖRTYOL PIPELINE PROJECT**

Financing: Local source

Latest State : Under File No **2017/84546** The tender was held for Batman-Dört Yol Crude oil Pipelines route field survey, mapping, expropriational services consultancy : On 26 May 2017 bids were received . With an approx. cost of 4.947.811,61 TL the lowest bid price of 2.390.000 TL (95,64 % score) was submitted by **ERME MÜH.+DERYA HARİTA (DETAY-1536)**. Locations: Batman, Diyarbakır, Şanlıurfa, Gaziantep, K. Maraş, Osmaniye , Hatay Provinces.

Project Name: **PIPELINES ROUTE FIELD SURVEY, MAPPING, EXPROPRIATIONAL SERVICES PROJECT**

Financing: Local source

Latest State : Under File No **2017/204361** The tender was held for Salihi- Alaşehir-Kula naturalgas Pipelines route field survey, mapping, expropriational services consultancy : Quoting 695.548,00 TL **SAR PROJE A.Ş.** received the contract . (**DETAY-1528**)

Latest State : Under File No **2017/204343** The tender was held for Balıkesir's Edremit and Burhaniye Districts naturalgas Pipelines route field survey, mapping, expropriational services consultancy , engineering: Quoting 647.715,66 TL **SAÇIN HARİTA** received the contract . (**DETAY-1528**)

Latest State : Under File No **2017/204366** The tender was held for Simav District naturalgas Pipelines route field survey, mapping, expropriational services consultancy , engineering: QUoting 307.280,00 TL , **YILDIZ HARİTA** received the contract . (**DETAY-1528**)

Latest State : Under File No **2017/204336** The tender was held for Beşikdüzü OSB naturalgas Pipelines route field survey, mapping, expropriational services consultancy, engineering: Quoting 724.100,00 TL , **PELİT MİMARLIK** received the contract. (**DETAY-1528**)

Latest State : Under File No **2017/204349** The tender was held for Espiye District naturalgas Pipelines route field survey, mapping, expropriational services consultancy , engineering: QUoting 299.666,00 TL , **UZMANEL MÜHENDİSLİK** received the contract .(**DETAY-1528**)

Management : **STATE HYDRAULIC WORKS (DSİ)**

Project Name: **LOWEN EUPHRATES 2. PHASE PROJECT**

Financing: Local source

Latest State : Under File No **2017/36526** The tender was held for Lower Euphrates 2 Phase consultancy services (1st stage) and quoting 11.000.000,00 TL , **TÜMAŞ TÜRK MÜHENDİSLİK A.Ş** received the contract (**DETAY-1549**)

Project Name: **K.MARAŞ-KISIK DAM PROJECT**

Financing: Local source

Latest State : Under File No **2016/562617** The tender was held for Kahramanmaraş-Kısıq Dam drinking water facilities Project services . On 11 April 2017 bids were received. With an approx. cost of 3.995.438,12 TL , quoting 4.100.315,00 TL **SU-YAPI MÜHENDİSLİK** received the contract . (**DETAY-1521**)

- Management : **STATE HYDRAULIC WORKS (DSİ) 2.BÖLGE MÜDÜRLÜĞÜ (İZMİR)**
Project Name: **MANİSA DRINKINGWATER PROJECT**
Financing: Local source
Latest State : Under File No **2016/564218** The tender was held for Manisa Drinkingwater Akçapınar Dam Planning Engineering Services: Quoting 1.190.000,00 TL, the contract was awarded to **HİDROMARK MÜH. MÜŞ. A.Ş.**
- Project Name: **POND PLANNING AND PROJECT SERVICES (02. BÖLGE)**
Financing: Local source
Latest State : Under File No **2016/510181** The 02 Region Ponds Planning Engineering Serv.under 6th stage: . With approx. cost of 3.059.433,00 TL, **EKATEK MÜH. MÜŞ. LTD. ŞTİ.** received contract at 2.952.000,00 TL (**DETAY-1541**)
- Management : **STATE HYDRAULIC WORKS (DSİ) 14.BÖLGE MÜDÜRLÜĞÜ (İSTANBUL)**
Project Name: **YILGIN POND PROJECT**
Financing: Local source
Latest State : Under File No **2017/279991** The tender was held for İstanbul Şile Yılgin Pond and Irrigation Facilities planning and Project services.Quoting 1.599.130,00 TL the contract awarded to **DOLSAR MÜHENDİSLİK A.Ş. (DETAY-1550).**
- Management : **STATE HYDRAULIC WORKS (DSİ) 19.BÖLGE MÜDÜRLÜĞÜ (SİVAS)**
Project Name: **VARIOUS POND PROJECTS**
Financing: Local source
Latest State : Under File No **2017/176723** The tender was held for Sivas Merkez Herekli,Sarkışla Baltalar Ponds and Irrigation Facilities, and quoting 1.280.000,00 TL the contract was awarded to **SU- YAPI MÜHENDİSLİK. (DETAY-1536)**
- Latest State : Under File No **2017/168864** The tender was held for Sivas İmranlı Türkkeşlik, Gölöva,Kızıldağ Ponds and Irrigation Facilities, and quoting 1.180.000,00 TL the contract was awarded to **SU- YAPI MÜHENDİSLİK. (DETAY-1536)**
- Latest State : Under File No **2017/176361** The tender was held for Sivas Divriği Çamşılı,Kangal Avşarören Ponds and Irrigation Facilities, and quoting 990.000,00 TL the contract was awarded to **EN-SU MÜHENDİSLİK. (DETAY-1536)**
- Latest State : Under File No **2017/170730** The tender was held for Sivas Yıldızeli Ortaklar, Ulaş Ovacık Ponds and Irrigation Facilities, and quoting 1.050.000,00 TL the contract was awarded to **HİDROMARK MÜHENDİSLİK MÜŞAVİRLİK A.Ş.. (DETAY-1536)**
- Management : **STATE HYDRAULIC WORKS (DSİ) 21.BÖLGE MÜDÜRLÜĞÜ (AYDIN)**
Project Name: **DALAMAN PLAIN IRRIGATION PROJECT**
Latest State : Under File No **2017/117474** The tender was held for Muğla-Dalaman Plain Irrigation Facilities Consultancy Control Services . With 9.800.000,00 TL , **KOLTEK MÜŞAVİRLİK+ERGES MÜHENDİSLİK** received contract (**DETAY-1548**).
Financing: Local source
Latest State : Under File No **2017/117487** The tender was held for Aydın-Koçarlı Bağarası Irrigation Facilities Consultancy and Control Serv. 2nd stage: With 9.750.000,00 TL, **TUMAŞ TÜRK MÜHENDİSLİK A.Ş** received contract .(**DETAY-1548**)
- Management : **STATE HYDRAULIC WORKS (DSİ) 22.BÖLGE MÜDÜRLÜĞÜ (TRABZON)**
Project Name: **STREAMS AND SUB BASINS UNDERGROUND WATER PLANNING PROJECT**
Latest State : Under File No **2017/277029** The 22 Region's coastal belt aquifers (İyidere Çayı, Taşlıdere Çayı, Büyükdere Çayı, Hemşin Deresi, Fırtına Deresi, Arılı Deresi, Abuçağlayan Deresi) sub basins underground waters planning (hydrogeological survey) report serv.: With 1.245.000,00 TL, **HİDRO DİZAYN A.Ş.** received contract (**DETAY-1547**)
- Management : **STATE AIRPORTS MANAGEMENT (DHMİ)**
Project Name: **GAZİANTEP, MUŞ AND ÇUKUROVA AIRPORTS CONSULTANCY SERVICES**
Latest State : Under File No **2016/503029** The tender was held on 7 March 2017 for Gaziantep, Muş and Çukurova Airports control and consultancy services , and quoting 12.987.000,00 TL the contract was awarded to **YÜKSEL PROJE ULUSLARARASI ANONİM ŞİRKETİ. (DETAY-1530)**
- Management : **GAZİANTEP M. MUNICIPALITY**
Project Name: **GAR-DÜZTEPE-HASTANE RAIL SYSTEM (METRO) PROJECT**
Financing: Local source
Latest State : Under File No **2017/67125** The tender was held for Gar-Düztepe-Hastane Light Rail System (Metro) Lines Final Project Services : With an approx. cost of 10.989.166,67 TL, 6.930.000,00 TL the contract was awarded to **IDOM CONSULTING ENGINEERING ARCHITECTURE S.A.U.. (DETAY-1540)**

- Management : **İSTANBUL M. MUNICIPALITY'S SUPERSTRUCTURE PROJECTS DEPARTMENT**
- Project Name: **2016/06 FILED PROJECT PREPAR. AND CONSULTANCY SERVICES**
Financing: Local source
Latest State : Under File No **2017/409697** The city general cultural, sports facilities and car parks Project services (2017/06) consultancy: At the 2nd round technical and price envelopes were received on 11 Dec. 2017. (**DETAY-1552**)
- Project Name: **2016/07 FILED PROJECT PREPAR. AND CONSULTANCY SERVICES**
Financing: Local source
Latest State : Under File No **2017/45025** The tender was held for İstanbul city general cultural, sports facilities and car parks Project services (2016/07): QUoting 8.769.400,00 TL, **YÜKSEL PROJE A.Ş** received the contract .(. (**DETAY-1549**)
- Project Name: **KAYNARCA-PENDİK-TUZLA SUBWAY PROJECT**
Financing: Local source
Latest State : Under File No **2017/188132** The tender was canceled for Kaynarca-Pendik-Tuzla Subway Building and Electromechanical Works Control Consultancy Engineering: On 2 Nov. 2017 9 firms submitted bids.(**DETAY-1551**)
- Project Name: **KABATAŞ TRANSFER CENTRE PROJECT**
Financing: Local source
Latest State : Under File No **2017/220982** The tender was held for Kabataş Transfer Centre Building Control and Consultancy Engineering on 14 Sep. 2017. Evaluation is underway on the applicants . (**DETAY-1546**)
- Project Name: **İSTANBUL LAND ROADS BUILDING PROJECTS**
Financing: Local source
Latest State : Under File No **2017/255744** The tender was held for "İstanbul City Land Roads Projects-2 Consultancy" on 24 July 2017 : Eligible firms submitted their Price envelopes on 25 Oct. 2017 (**DETAY-1545**)
- Project Name: **İSTANBUL CITY GENERAL INFRASTRUCTURE PROJECTS**
Financing: Local source
Latest State : Under File No **2017/54268** The tender was held for İstanbul city general green areas streets, squares arrangement: With 6.212.200,00 TL bid offer, **TÜMAŞ TÜRK MÜHENDİSLİK A.Ş** received the contract (**DETAY-1545**)
- Project Name: **İSTANBUL CITY GENERAL INFRASTRUCTURE PROJECTS (2016/19)**
Latest State : Under File No **2016/536478** The tender was held for İstanbul city general green areas , maritime structures , squares, coastal belt arrangement (2016/19): With an approx. cost of 16.205.812,00 TL the contract was awarded to **TÜMAŞ TÜRK MÜH. MÜŞ. A.Ş.** quoting 6.994.750,00 TL (**DETAY-1539**)
- Project Name: **İSTANBUL CITY GENERAL INFRASTRUCTURE PROJECTS (2016/08)**
Latest State : Under File No **2017/78976** The tender was held for İstanbul city general streets,roads car parks, squares arrangement project services (2016/08):. With an approx. cost of 14.162.413,75 TL, the contract was awarded to **BİMTAŞ BOĞAZIÇI A.Ş.** quoting 8.494.000,00 TL. (**DETAY-1539**)
- Project Name: **İSTANBUL CITY GENERAL INFRASTRUCTURE PROJECTS (2017/02)**
Latest State : Under File No **2017/185970** The tender was held for İstanbul city general,roads tunnels, squares arrangement project services (2017/02) , and quoting 3.237.830,00 TL **EMAY MÜHENDİSLİK** received the contract . (**DETAY-1537**)
- Project Name: **İSTANBUL CITY GENERAL INFRASTRUCTURE PROJECTS (2017/01)**
Latest State : Under File No **2017/183386** The tender was held for İstanbul city general,roads tunnels, squares arrangement project services (2017/01). Evaluation is underway . (**DETAY-1537**)
- Project Name: **BEYOĞLU-KABATAŞ TRANSFER CENTRE IMPLEMENTATION PROJECT (2017/04)**
Latest State : Under File No **2017/207299** The tender was held for Beyoğlu Kabataş Transfer Centre Implementation (2017/04): Quoting 12.420.000,00 TL **BİMTAŞ BOĞAZIÇI İNŞAAT** received the contract . (**DETAY-1534**)
- Project Name: **İSTANBUL CITY GENERAL INFRASTRUCTURE PROJECTS (2017/22)**
Latest State : Under File No **2017/58601** The tender was held for İstanbul city general green areas , maritime structures , squares, coastal belt arrangement, project services (2016/22): Envelopes were opened on 20 July 2017. With an approx. cost of 15.373.241 TL, **MESCİOĞLU MÜH.** received the contract quoting 6.264.100,00 TL (**DETAY-1535**)
- Project Name: **İSTANBUL CITY GENERAL INFRASTRUCTURE PROJECTS (2017/10)**
Latest State : Under File No **2017/61445** The tender was held for İstanbul city general streets,roads car parks, squares arrangement project services (2016/10): Envelopes were opened on 19 July 2017.. With an approx. cost of 15.041.170 TL **TÜMAŞ TÜRK MÜH. A.Ş.** received the contract quoting 8.464.000,00 TL (**DETAY-1535**)

- Project Name: **İSTANBUL CITY GENERAL INFRASTRUCTURE PROJECTS (2017/16)**
 Latest State : Under File No **2017/61445** The tender was held for (2016/16) city general Project services on 30 March 2017. Quoting 8.864.490,00 TL, **ERKA-AS PROJE LTD** received the contract . (DETAY-1519)
- Project Name: **İSTANBUL CITY GENERAL ROADS & JUNCTIONS ARRANGEMENT & IMPLEMENTATION PROJECT SERVICES**
 Latest State : Under File No **2016/490543** The tender was held for İstanbul city general,roads, squares, traffic improvement arrangement prj.serv.on 6 June 2017. **EMAY MÜH.** received contract with 3.933.921,00 TL. (DETAY-1529)
- Project Name: **EYÜP-BAYRAMPAŞA RAIL SYSTEM LINES AND ESENLER NOSTALGIC TRAMWAY IMPLEMENTATION PROJECT SERVICES**
 Latest State : Under File No **2016/33897** The tender was held for Eyüp-Bayrampaşa rail System Lines and Esenler Nostalgic Tram Lines Final Project Services (6 km) , and quoting 2.950.000,00 TL **ARUP MÜHENDİSLİK VE MÜŞAVİRLİK LTD.ŞTİ. OVE ARUP & PARTNERS İNTERNATİONAL LTD.** received the contract . (DETAY-1525)
- Project Name: **SARIGAZI-TÜRKİŞ BLOKLARI SUBWAY LINES IMPLEMENTATION PROJECT**
 Latest State : Under File No **2016/401543** The Sarigazi-Türkiş Blokları Subway Lines İmplementation Final Project Services, and quoting 2.112.500,00 TL **GEODATA ENGINEERING S.P.A** received the contract . (DETAY-1515)
- Project Name: **KAZLIÇEŞME-SÖĞÜTLÜÇEŞME SUBWAY LINES IMPLEMENTATION PROJECT (1. PHASE)**
 Latest State : Under File No **2016/374508** The Kazlıçeşme-Söğütlüçeşme Subway Lines (Phase 1) İmplementation Final Prj. (20 km). With 6.971.000,00 TL the contract awarded to **GEODATA ENGINEERING S.P.A** (DETAY-1515)
- Project Name: **KABATAŞ-BAĞCILAR TRAMWAY LINES SEYİTNİZAM - ZEYTİNBURNU STATIONS ROUTE REBUILDING UNDERGROUND**
 Latest State : Under File No **2016/375932** The tender was held for Kabataş-Bağcılar Tram Lines Seyitnizam - Zeytinburnu Stations Section Underground Construction and Başakşehir-Kayaşehir Subway Lines Expansion İmplementation Final Project Services: Quoting 2.340.000,00 TL **İDOM İNTEGRİA CONSULTORİA S.A.** received the contract . (DETAY-1515)
- Project Name: **KADIKÖY-SULTANBEYLİ RAIL SYSTEM LINES ROUTE IMPLEMENTATION PROJECT SERVICES**
 Latest State : Under File No **2016/454668** The tender was held for Kadıköy-Sultanbeyli Rail System Subway lines İmplementation Final Prj Serv: Quoting 7.600.000,00 TL, **PROTA MÜH. A.Ş. SİNTAGMA S.R.L.** received contract . (DETAY-1515)
- Project Name: **İSTANBUL SUBWAY PROJECTS**
 Latest State : Under File No **2017/188087** The **Ümraniye-Ataşehir-Göztepe Subway Lines** Civil works Electromechanical Works Control and Consultancy Engineering; Eligible firms submitted offers on 1 Aug. 2017.(DETAY-1537)
 Latest State : Under File No **2017/188121** The **Çekmeköy-Sancaktepe-Sultanbeyli Subway Lines and Sarigazi (Hastane)-Taşdelen-Yenidoğan Subway Lines Lines** Civil works and Electromechanical Works Control and Consultancy Engineering; Eligible firms submitted their offers. (DETAY-1537)
 Latest State : Under File No **2017/157016** The **Kirazlı-Halkalı Subway Lines Lines** Civil works Electromechanical Control Consultancy Engineering; Eligible firms submitted offers. Evaluation is underway . (DETAY-1537)
 Latest State : Under File No **2017/157041** The tender was held for **Başakşehir-Kayaşehir Subway Lines Lines** Civil works and Electromechanical Control Consultancy Engineering; Eligible firms submitted offers. (DETAY-1537)
 Latest State : Under File No **2017/156914** The **Mahmutbey-Esenyurt Subway Lines Lines** Civil works Electromechanical Works Control and Consultancy Engineering; Eligible firms submitted their offers. Evaluation is underway . (DETAY-1537).
 Latest State : Under File No **2017/188132** The **Kaynarca-Pendik-Tuzla Subway Lines Lines** Civil works and Electromechanical Works Control Consultancy Engineering; Eligible firms submitted offers. But the tender was canceled (DETAY-1537).
 Latest State : Under File No **2017/156960** The **Sefaköy-Başakşehir Havaray Hattı Lines** Civil works and Electromechanical Control Consultancy Engineering; Eligible firms submitted offers. But the tender was canceled (DETAY-1537).
- Management : **İSTANBUL WATER AND SEWERAGE ADMINISTRATION (İSKİ)**
 Project Name: **2016/06 FILED PROJECT PREPAR. AND CONSULTANCY SERVICES**
 Latest State : Under File No **2017/255051** The tender was held for drinking water and sewerage master plan services: Deadline 25 Dec. 2017 for technical and price envelopes. .(DETAY-1549)
- Management : **İZMİR M. MUNICIPALITY**
 Project Name: **2016/06 FILED PROJECT PREPAR. AND CONSULTANCY SERVICES**
 Financing: Local source
 Latest State : Under File No **2017/118240** The tender was held for İzmir light rail System Sistemi 5.Stage Üçyol Station-DEÜ Tınaztepe Kampusu-Buca Koop route tunnel, stations, depot area and vehicle procurement control and consultancy engineering services : Bids were received on 28 Sep. 2017. Evaluation is underway (DETAY-1538)

- Management : **İSTANBUL GAZ DAĞITIM A.Ş. (İGDAŞ)**
- Project Name: **NATURALGAS DISTRIBUTION LINES BUILDING CONTROL SERVICES**
- Financing: Local source
- Latest State : Under File No **2017/161922** The tender was held for D (27) Naturalas Distribution Lines building control and supervision services: On 11 Apr. 2017 bids were received . With an approx. cost of 7.323.772,00 TL **TÜMAŞ TÜRK MÜH. A.Ş** received the contract quoting , 4.897.000,00 TL. (**DETAY-1530**)
- Management : **STATE HIGHWAYS ADMINISTRATION (KGM)**
- Project Name: **TOMARZA-TUFANBEYLİ (GÖKSU-SARIZ) ROAD PROJECT**
- Financing: Local source
- Latest State : Under File No **2017/406305** The tender was held for KGM 6. Bölge Müdürlüğü (Kayseri) Tomarza-Tufanbeyli-(Göksun-Sarız) Junc..(53 km) road survey and consultancy: Bids were received on 22 Nov. 2017 (**DETAY-1552**)
- Project Name: **12. BÖLGE'S (ERZURUM) ROAD PROJECT**
- Financing: Local source
- Latest State : Under File No **2017/503836** The tender was held for 12.Bölge Müdürlüğü (Erzurum) roads (1. Stage, 27 km, 2. Stage 15 km) totalling 42 Km. route survey and consultancy : Applications were received on 13 Nov. 2017 . (**DETAY-1551**)
- Project Name: **(PAZAR-FINDIKLI) JUNC.. ARDEŞEN-TUNCA PROV. ROAD PROJECT**
- Latest State : Under File No **2017/349629** The tender was held for (Pazar-Fındıklı) Junc. Ardeşen-Tunca route survey consultancy : Quoting 1.360.000,00 TL contract was awarded to **PETEK PROJE MÜH. MÜŞ. A.Ş.** (**DETAY-1551**)
- Project Name: **ELAZIĞ MALATYA JUNC. SINCİK (GAP) ROAD PROJECT**
- Financing: Local source
- Latest State : Under File No **2017/512632** The tender was held for 8. Bölge Müdürlüğü border roads (Elazığ-Malatya)Junc..- Sincik (GAP) road (60 km) survey and consultancy services : Applications were received on 6 Nov. 2017. At a 2nd round price envelopes will be submitted on 28 Dec. 2017. (**DETAY-1550**)
- Project Name: **4. BÖLGE MÜDÜRLÜĞÜ'S VARIOUS ROAD PROJECTS**
- Latest State : Under File No **2017/203991** The tender was held for 4. Bölge Müdürlüğü border roads survey and consultancy services: QUoting 1.167.100,00 TL **FKM MÜHENDİSLİK** received the contract .(**DETAY-1550**)
- Project Name: **4. BÖLGE MÜDÜRLÜĞÜ'S VARIOUS ROAD PROJECTS**
- Latest State :**2017/203991** The tender was held for 4. Bölge Müdürlüğü border roads survey and consultancy services: Quoting 1.710.600,00 TL **FKM MÜHENDİSLİK** received the contract .(**DETAY-1550**)
- Project Name: **5. BÖLGE MÜDÜRLÜĞÜ'S VARIOUS ROAD PROJECTS**
- Financing: Local source
- Latest State : Under File No **2017/208072** The 5. Bl. Md. (Mersin) border roads survey consultancy: **ERBİL PROJE A.Ş** is winner with an approx. cost of 15.412.447,85 TL (App. Cost based on cont. :2.637.519,22 TL) Contr. value 2.597.000,00 TL.
- Project Name: **13. BÖLGE MÜDÜRLÜĞÜ'S VARIOUS ROAD PROJECTS**
- Financing: Local source
- Latest State : Under File No **2017/499228** The tender was held for (Söğüt-Seydikemer) junc..-Dirmil-Göhlisar-(Antalya-Denizli) junc..-2. Bl. Hd. road survey and consultancy services : Deadline fixed as 27 Dec. 2017 for proposals.(**DETAY-1549**)
- Project Name: **13. BÖLGE MÜDÜRLÜĞÜ'S VARIOUS ROAD PROJECTS**
- Financing: Local source
- Latest State : Under File No **2017/307237** The tender was held for 11. Bl. Md. roads survey and consultancy services: Quoting 1.791.000,00 TL the contract was awarded to **BİL-TEK MÜH. LTD.ŞTİ.** (**DETAY-1549**)
- Project Name: **1. BÖLGE MÜDÜRLÜĞÜ'S EXPROPRIATIONAL SERVICES**
- Financing: Local source
- Latest State : Under File No **2017/422415** The tender was held for KGM 1. (İstanbul) and 16. Bölge (Sivas) Müdürlükleri roads expropriational services consultancy: Deadline fixed as 5 Dec. 2017 for proposals. (**DETAY-1549**)

Project Name: 8. BÖLGE MÜDÜRLÜĞÜ'S ROAD PROJECT

Financing: Local source

Latest State : Under File No **2017/439025** The tender was held for 8. Bölge Müdürlüğü border roads survey and consultancy services : Deadline fixed as 28 Nov. 2017 for technical and price envelopes (**DETAY-1553**)**Project Name: 15. BÖLGE MÜDÜRLÜĞÜ'S ROAD PROJECT**

Financing: Local source

Latest State : Under File No **2016/406632** The tender was held for 15. Bölge Müdürlüğü (Kastamonu) roads survey and consultancy services : Quoting 30.756.600,00 TL **TÜMAŞ TÜRK MÜH+ AKKOL MÜH.** received the contract . (**DETAY-1507**)**Project Name: MARDİN PERIPHERAL ROAD PROJECT**

Financing: Local source

Latest State : Under File No **2017/204231** The Mardin Peripheral Road survey consultancy held on 7 Aug. 2017. With an approx. cost of 4.218.761,70 TL , contract was awarded to **MEGA MÜHENDİSLİK** quoting 4.192.000,00 TL (**DETAY-1538**)**Project Name: SARIKAYA-SORGUN AYRIMI-AKDAĞMADENİ ROAD PROJECT**

Financing: Local source

Latest State : Under File No **2017/90381** for KGM 6. Bölge Müd. border rads (Sarıkaya-Sorgun) junc. Akçakışla - Akdağmadeni road Survey consultancy: With 1.595.000,00 TL **OPTİM OBERMEYER PROJE A.Ş.** received contract . (**DETAY-1538**)**Project Name: ANKARA-NİĞDE HIGHWAY PROJECT WITH BOT MODEL**

Financing: BUILD-OPERATE-TRANSFER (BOT)

Latest State : The tender was held on 6 June 2017 for consultancy of the Ankara-Niğde Highway Project on the basis of Build-Operate-Transfer Model: . Quoting 82.928.920,00 TL **ALTINOK MÜŞAVİRLİK.+YÜKSEL DOMANIÇ** received the contract. Approx. Cost : 85.211.600,00 TL. (**DETAY-1536**)**Project Name: ÇANAKKALE BRIDGE PROJECT**

Financing: BUILD-OPERATE-TRANSFER (BOT)

Latest State : The tender was held for for consultancy services of the Kınalı-Tekirdağ-Çanakkale-Savaştepe Highway Project Malkara-Çanakkale (1915 Çanakkale Bridge Included) Section on the basis of Build-Operate-Transfer Model: Quoting 164.319.540 TL **TEKFEN MÜH. + PARSONS TRANSPORTATION GROUP** received the contract . (**DETAY-1527**)**Project Name: TRANSPORT AND DISTRIBUTION FACILITIES EARTHQUAKE REGULATION CONSULTANCY SERVICES**

Financing: Local source

Latest State : Under File No **2017/93978** The tender was held for Earthquake Regulations Preparation Consultancy For Transport and Distribution Facilities on 11 May 2017: Quoting 3.856.000,00 TL **YÜKSEL PROJE A.Ş** is winner (**DETAY-1525**)**Project Name: MENEMEN-ALIAĞA-ÇANDARLI HIGHWAY PROJECT**

Financing: BUILD-OPERATE-TRANSFER (BOT)

Latest State : The tender was held on 2 May 2017 for consultancy services of the Menemen-Aliağa-Çandarlı Highway Project on the basis of Build-Operate-Transfer Model. TL. And Quoting 45.839.350 TL **UBM ULUSL. MÜH. MÜŞ. A.Ş.** received the contract with an approx. cost of 56.455.490,00 TL. (**DETAY-1524**)**Project Name: BOSPHORUS AND FSM BRIDGES WATER DRAINAGE CONSTRUCTION CONTROL SERVICES**

Financing: Local Source

Latest State : Under File No **2016/414069** The tender was held on 6 Jan. 2017 for Bosphorus Bridge main Wire fixed chute area passage reinforcement and Fatih Sultan Mehmet Bridge (FSM) boltings water drainage construction engineering and control services : With an approx. cost of 12.490.848,00 TL, **PARSONS TRANSPORTATION GROUP INC. MERKEZİ ABD İSTANBUL MERKEZ ŞUBESİ** received the contract quoting 16.000.020 TL (**DETAY-1507**)**Management : KGM 12. BÖLGE MÜDÜRLÜĞÜ (ERZURUM)****Project Name: ERZURUM-TORTUM-UZUNDERE TUNNEL CROSSING PROJECT**

Financing: Local source

Latest State : **2017/305226** The tender was held for Erzurum-Tortum-Uzundere-10 Bölge HD (Km:15+000-29+700) tunnel crossing survey and engineering services : Quoting 1.400.000,00 TL the contract was awarded to **ALTER ULUSLARARASI MÜH.+ERYOL MÜH. LTD. ŞTİ.** (**DETAY-1551**)

- Project Name: TORTUM-İSPİR PROV. ROAD PROJECT REVISION SERVICES**
Financing: Local source
Latest State : Under File No **2017/318635** The Tortum-İspir Prov. Road Stages I (Km:0+00000 26+40000); II (Km:28+76000-53+20000) revision consultancy : With 2.560.000,00 TL **SU-YAPI MÜH.+SAR PROJE İNŞ. A.Ş.** is the winner
- Management : MERSİN M. MUNICIPALITY**
Proje Adı : **MERSİN GAR-MEZİTLİ RAIL SYSTEM PROJECT**
Son Durumu : Under File No **2017/499826** The tender was held for Gar-Mezitli Rail System Lines implementation Final Project Services: Deadline fixed as 5 Dec. 2017 for technical and price envelopes. (**DETAY-1551**)
- Management : STATE RAILWAYS ADMINISTRATION (TCDD)**
Project Name: **BANDIRMA-BURSA-AYAZMA-OSMANELİ HIGH SPEED TRAIN PROJECT**
Financing: Local source
Latest State : Under File No **2017/335827** The tender was held for Bandırma-Bursa-Ayazma-Osmaneli High Speed Train Project (Tunnels excluded) infrastructure consultancy and control services: Deadline fixed as 27 Dec. 2017 for technical and price envelopes at a 2nd round. (**DETAY-1552**)
- Project Name: GAZİANTEP-ŞANLIURFA RAILWAY PROJECT**
Financing: Local source
Latest State : Under File No **2017/274850** The tender was held for Gaziantep-Şanlıurfa Railway lines (infrastructure, superstructure, electromechanical works) survey and engineering consultancy services: Deadline fixed as 20 Dec. 2017 for technical and price envelopes at a 2nd round. (**DETAY-1552**)
- Project Name: SALİHLİ-MANİSA SECTION RAILWAY PROJECT**
Financing: Local source
Latest State : Under File No **2017/315983** The Ankara - İzmir High Speed Train Project Salihli - Manisa Section (km:439+000-501+000) infrastructure survey and engineering consultancy: Prices were received on 17 Nov. 2017. (**DETAY-1551**)
- Project Name: ANKARA-İSTANBUL HIGH SPEED TRAIN PROJECT (SAPANCA-GEYVE)**
Latest State : Under File No **2017/514838** The tender was held for Sapanca-Geyve (Doğançay-Sapanca) high speed train route infrastructure survey and engineering consultancy services: Applications were received on 9 Nov. 2017. Price envelopes will be received at the 2nd round. (**DETAY-1550**)
- Project Name: GÖLBAŞI-ADİYAMAN-KAHTA RAILWAY PROJECT**
Financing: Local source
Latest State : Under File No **2017/2614** The tender was held for Gölbaşı-Adıyaman-Kahta Railway Lines (100 km) survey and engineering consultancy: Quoting 7.427.000,00 TL **ERKA-AS PROJE LTD.** received the contract. (**DETAY-1547**)
- Project Name: MALATYA-ELAZIĞ RAILWAY PROJECT**
Financing: Local source
Latest State : Under File No **2017/411334** The Malatya - Elazığ Railway Lines (121 km) (infrastructure, superstructure, electromechanical w.) survey engineering consultancy: Applications received on 12 Oct. 2017 (**DETAY-1546**)
- Project Name: SİİRT-KURTZALAN RAILWAY PROJECT**
Financing: Local source
Latest State : Under File No **2017/393970** The Siirt-Kurtalan Railway Lines (infrastructure superstructure) survey and engineering consultancy services (24 km): Applications received on arı 21 Sep. 2017.. Evaluation underway (**DETAY-1543**)
- Project Name: ANKARA-İZMİR YHT PROJECT/ EŞMA-SALİHLİ SECTION**
Financing: Local source
Latest State : Under File No **2017/340239** The Ankara-İzmir High Speed Train Project's Eşme Salihli Section infrastructure survey and engineering consultancy services: Applications received on 8 Sep. 2017. Evaluation is underway (**DETAY-1541**)
- Project Name: KIRŞEHİR-AKSARAY RAILWAY PROJECT**
Financing: Local source
Latest State : Under File No **2017/375118** The tender was held for Kırşehir-Aksaray Railway Lines (infrastructure, superstructure, electromechanical works) survey and engineering consultancy services: Deadline fixed as 8 Dec. 2017 for technical and price envelopes at a 2nd round. (**DETAY-1552**)

Project Name: TOKAT-TURHAL RAILWAY PROJECT

Financing: Local source
Latest State : Under File No **2017/375869** The tender was held for Tokat-Turhal Railway Lines (infrastructure, signalling telecommunications) survey and engineering consultancy services (42 km) survey and engineering consultancy services: Applications received on 21 Aug. 2017. Evaluation is underway (**DETAY-1540**)

Project Name: KONYA (KAYACIK) LOGISTICS CENTRE PROJECT

Financing: Local source
Latest State : Under File No **2017/182761** Konya (Kayacık) Logistics Centre survey and engineering consultancy services : Applications received on 2 June 2017 and bids on 19 Sep. 2017. But the tender was canceled (**DETAY-1538**)

Project Name: KARS LOGISTICS CENTRE PROJECT

Latest State : Under File No **2017/133573** The tender was held for Kars Logistics Centre and Railway Connection control and consultancy services : Quoting 1.139.985,00 TL **TÜMAŞ TÜRK MÜH. A.Ş.** received the contract . (**DETAY-1533**)

Project Name: ANKARA İZMİR YHT PROJECT AFYONKARAHISAR-UŞAK (BANAZ) SECTION CROSSING INFRASTRUCTURE

Financing: Local source
Latest State : Under File No **2017/315520** The tender was held for Ankara - İzmir High Speed Train Project's Afyonkarahisar-Uşak (Banaz) Section (Km:194+235 Km:268+000) and Afyonkarahisar Direct Crossing Infrastructure control and consultancy services : Technical and price envelopes received on 26 Dec. 2017 (**DETAY-1557**)

Project Name: ANKARA İZMİR YHT PROJECT BANAZ-EŞME SECTION PROJECT

Financing: Local source
Latest State : Under File No **2016/122265** The tender was held for Ankara-İzmir High Speed Train Project's Banaz-Eşme Section (km268+000-km364+600) infrastructure works control and consultancy services : Quoting 14.994.990,00 TL the contract was awarded to **ALTINOK MÜŞ. MÜH. A.Ş.** (**DETAY-1517**)

Project Name: NURDAĞI-KAHRAMANMARAŞ RAILWAY PROJECT

Latest State : Under File No **2017/2565** After a tender on 8 Feb. 2017 for the 63 km Nurdağ-Kahramanmaraş Railway Lines (infrastructure superstructure works) control – consultancy, proposals received on 2 June 2017. (**DETAY-1527-1531**)

Project Name: GAZİRAY PROJECT

Latest State : Under File No **2016/101221** The tender was held for Başpınar-Gaziantep-Mustafa Yavuz Stations route reconstruction infrastructure superstructure works (GAZİRAY) control and consultancy services : Price envelopes were received on 26 May 2017. With an approx. cost of 9.618.093,38 TL, **ALTINOK MÜŞVARLIK** received the contract quoting 6.942.900,00 TL. (**DETAY-1527**)

Project Name: ANKARA-SİVAS RAILWAY PROJECT

Financing: Local source
Latest State : Under File No **2016/108403** The tender was held for Ankara-Sivas Railway Project Kayaş-Kırıkkale route Section I (Kayaş-Elmadağ) (Km 12+263-45+440) infrastructure works control and consultancy services : Quoting 13.333.628 TL **UBM ULUSL. BİRLEŞMİŞ MÜŞAVİRLER MÜŞ. HİZ. A.Ş.** received the contract .(**DETAY-1522**)
Latest State : Under File No **2016/119827** The tender was held for Ankara-Sivas Railway Project's Elmadağ-Kırıkkale (Km 45+440-74+100) (V7-V9-V10-V15 Viaducts Excl.) infrastructure works control and consultancy services: Quoting 13.398.948,00 TL the contract awarded to **UBM ULUSL. BİRLEŞMİŞ MÜŞAVİRLER MÜŞ. HİZ. A.Ş.**(**DETAY-1522**)

Management : STATE RAILWAYS ADMINISTRATION- 6. BÖLGE MÜDÜRLÜĞÜ**Project Name: ADANA-İMAMOĞLU-KOZAN-KADIRLI-OSMANIYE RAILWAY CONNECTION PROJECT**

Latest State : Under File No **2017/244080** The tender was held for Adana- İmamoğlu-Kozan-Kadirli-Osmaniye Railway Connection Lines control -consultancy services: With 2.050.275,00 TL the contract awarded to **TÜMAŞ TÜRK MÜHENDİSLİK**.

Management : MASS HOUSING ADMINISTRATION (TOKİ)**Project Name: 15TH AND 18TH PACKAGES OF BUILDING CONSULTANCY SERVICES**

Latest State : Under File No 2017/110687: The tender was held for control and consultancy services during pre-building, building and post building periods in 15 groups: Quoting 27.043.416,00 TL **OPTİM OBERMEYER+PETA** is the winner.
Latest State : Under File No 2017/132418 The tender was held for for various control and consultancy services during pre-building, building and post building periods in 18 packages: With 22.988.138,59 TL **METROPLAN+BCT** received the contract

INDUSTRIAL RAW & AUXILIARY MATERIAL TENDERS

- **ANKARA M.MUNICIPALITY** : 50.000 ton Aluminium silicate added fired salt
Tender reg.no : **2017/382832**
Bid deadline : 13.09.2017
Approx. Cost : 10.500.000,00 TL
Quoting 6.375.000,00 TL, **BULDUK TUNCER TUZ. NAK. TAAH. VE TİC.LTD. ŞTİ.** received the contract.
- **ANKARA M.MUNICIPALITY** : 11 items explosives and ignition systems
Tender reg.no : **2017/66730**
Bid deadline : 29.09.2017
Approx. Cost : 10.500.000,00 TL
Quoting 4.672.110,00 TL, **ORİCA-NİTRO PATLAYICI MAD. SAN. TİC. A.Ş.** received the contract.
- **ANKARA-ASKİ ADMINISTRATION:** 1.300 ton liquid chloride.
Tender reg.no : **2017/339470**
Bid deadline : 14.08.2017
Approx. Cost : 1.430.000,00 TL
Quoting 196.300,00 TL, **AK KİM KİMYA A.Ş** received the contract.
- **AKSARAY MUNICIPALITY** : Chemical materials.
Tender reg.no : **2017/485371**
Bid deadline : 26.10.2017
Approx. Cost : 685.226,67 TL
Quoting 632.878,00 TL, **KORUMA KLOR ALKALİ SAN. A.Ş** received the contract. .
- **BAYBURT İL ÖZEL İDARESİ:**70/100 Bitumenous materials
Tender reg.no : **2017/443745**
Bid deadline : 11.10.2017
Approx. Cost : 2.272.824,00 TL
Quoting 2.250.000,00 TL, **UHA PETROL TAŞIMACILIK TİC. LTD.** received the contract. .
- **BAYBURT İL ÖZEL İDARESİ:** Aggregate materials
Tender reg.no : **2017/530841**
Bid deadline : 23.10.2017
Approx. Cost : 195.055,40 TL
Quoting 186.610,00 TL, **CEBESAN İNŞ.** received the cont.
- **BURSA M.MUNICIPALITY** : 10.000 ton rock salt procurement for winter use..
Tender reg.no : **2017/391683**
Bid deadline : 06.09.2017
Approx. Cost : 1.210.000,00 TL
Quoting 930.000,00 TL, **ÖZ DEMİRELLER HARF. NAKL. LTD. ŞTİ.** received the contract. .
- **BURSA-BUSKİ ADMINISTRATION:** 1000 ton sodium hypochloride.
Tender reg.no : **2017/479653**
Bid deadline : 30.10.2017
Approx. Cost : 1.210.000,00 TL
Quoting 480.000,00 TL, **KORUMA KLOR SAN. VE TİC. AŞ** received the contract. .
- **BELKO ADMINISTRATION (ANKARA)** Ankara M.Municipality's Ankara Kömür Asfalt Enerji İnşaat Sanayi Ve Ticaret LTD. (BELKO) opens tender for 18-70 mm 85.000 ton coals in 25 kg bags.
Tender reg.no : **2017/374521**
Bid deadline : 07.09.2017
Approx. Cost : 53.074.000,00 TL
Quoting 46.750.000,00 TL, **ATAKAŞ TİCARET VE NAKLİYAT A.Ş.** received the contract.
- **ÇAYKUR GENEL MÜDÜRLÜĞÜ:** 12.500 ton coal procurement
Tender reg.no : **2017/168447**
Bid deadline : 17.05.2017
Approx. Cost : 8.925.000,00 TL
Quoting 7.369.500,00 TL, **AKRABE MADENCİLİK AŞ** received the contract.
- **DENİZ İKMAL MERKEZİ KOMUTANLIĞI:** 2 items fire fighting foam liquid
Tender reg.no : 2017/194289
Bid deadline : 30.05.2017
Approx. Cost : 360.750,00 TL
Quoting 285.500,00 TL, **BİLDEN KİMYA SAĞLIK AMBALAJ TİC.** received the contract.
- **STATE AIRPORTS MANAGEMENT (DHMİ):** 1.500 Ton de-icer.
Bid deadline : 13.06.2017
Approx. Cost : 5.944.200 TL
Quoting 1.192.500 Euro, **OMEX ENVIROMENT (UK) Repr.:** **ADALI GRUP** received the contract.
- **ERZURUM-ESKİ ADMINISTRATION:** 2.500 ton Aluminium sulphate procur.
Tender reg.no : **2017/372479**
Bid deadline : 21.08.2017
Approx. Cost : **1.781.666,66 TL**
Quoting 1.365.000,00 TL, **AKFERAL SU KİMYASALLARI SANAYİ A.Ş** received the contract. .
- **ETİ MADEN İŞLETMELERİ ADMINISTRATION** : For Kırka Bor İşletme Müdürlüğü. 4.000 kg fuse sensitive explosives (dynamite), 160.000 kg. anfo (priming sensitive explosives), 60.000 kg. emulsion explosives (water resistant, priming sensitive explosives).
Tender reg.no : **2017/216882**
Bid deadline : 29.05.2017
Quoting 553.945,50 TL, **KOMANDO AV SİLAH A.Ş.** received the contract.
- **GAZİANTEP M.MUNICIPALITY** : 4.000 ton salt procur...
Tender reg.no : **2017/466896**
Bid deadline : 13.11.2017
Approx. Cost : 540.000,00 TL
Quoting 436.000,00 TL, **ÖZDENİZ TUZ TAŞIMACILIK LTD. ŞTİ.** received the contract. .

- **İSTANBUL M.MUNICIPALITY : 4.000 ton salt procur..**
Tender reg.no : **2017/91616**
Bid deadline : 17.04.2017
Approx. Cost : 15.739.196,00 TL
Winners:
- **İtem 1-European side 1 salt procurement for snow and ice control on roads**
Winner : **BİNBİR GIDA TARIM ÜRÜNL.**
Contract cost : 11.890.000,00 TL
- **İtem 2- European side 2 salt procurement for snow and ice control on roads**
Winner : **KOYUNCU NAKLİYE PAZ.**
Contract cost : 11.500.000,00 TL
- **İSTANBUL-İSKİ ADMINISTRATION : Aluminium sulphate procur.**
Tender reg.no : **2017/437206**
Bid deadline : 13.10.2017
Approx. Cost : 2.958.333,34 TL
Quoting 2.690.000,00 TL, **HİCRİ ERCİLİ DENİZ NAKLİYAT LTD.** received the contract .
- **İSTANBUL-İSKİ ADMINISTRATION : Aluminium sulphate procur.**
Tender reg.no : **2017/389074**
Bid deadline : 21.10.2017
Approx. Cost : 22.948.000,00
Quoting (1.item and 3.item) 12.053.300,00 TL, **HİCRİ ERCİLİ DENİZ NAKLİYAT TİC.** received the contract .
- **İSTANBUL-İSKİ ADMINISTRATION : Aluminium sulphate procur.**
Tender reg.no : **2017/389074**
Bid deadline : 21.10.2017
Approx. Cost : 22.948.000,00
Quoting (2. item and 4.item) 6.030.500,00 TL, **AKFERAL SU KİMYASALLARI A.Ş.** received the contract .
- **İSTANBUL-İSKİ ADMINISTRATION: For sludge dewatering unit, polyelectrolide procur.**
Tender reg.no : **2017/329577**
Bid deadline : 15.08.2017
Approx. Cost : 1.005.000,00 TL
Quoting 799.000,00TL, **SNF FLOERGER KİMYA TİC. LTD. ŞTİ.** received the contract .
- **İSTANBUL-İSKİ ADMINISTRATION : sludge dewatering unit, polyelectrolide procur .**
Tender reg.no : **2017/437206**
Bid deadline : 13.09.2017
Approx. Cost : 2.958.333,34 TL
Quoting 2.690.000,00 TL, **HİCRİ ERCİLİ DENİZ NAKLİYAT LTD.** received the contract .
- **STATE HIGHWAYS ADMINISTRATION- 6. BÖLGE MÜDÜRLÜĞÜ; De-icer solution**
Tender reg.no : **2017/432257**
Bid deadline : 27.10.2017
Approx. Cost : **644.996,25 TL**
Quoting 388.125,00 TL, **ASKİM KİMYEVİ MADDELER** received the contract.
- **KARAYOLLARI 6. BÖLGE MÜDÜRLÜĞÜ; 11650 ton rock salt, 11350 ton lake salt procur.**
Tender reg.no : **2017/268111**
Bid deadline : 06.06.2017
Approx. Cost : 2.868.539,64 TL
Quoting 2.449.500,00 TL, **MUTLUCAN TUZ MAD. İNŞ A.Ş** received the contract.
- **MALATYA M.MUNICIPALITY : 2.000 ton salt procur.**
Tender reg.no : **2017/532184**
Bid deadline : 16.11.2017
Approx. Cost : 383.340,00 TL
Quoting 330.000,00 TL **KOYUNCU A.Ş.** received the contract.
- **MKEK ADMINISTRATION : 1.000 kg. 1-4 Diamino 2-3 Dihydro Anthracinon, 1.000 kg. 1 Metyle raw materials procur.**
Tender reg.no : **2017/341622**
Bid deadline : 29.09.2017
Quoting 58.350,00 \$ the US-based **MIL-SPEC INDUSTRIES CORPORATION** received the contract (Free on C&F Turkey basis)
- **MANİSA KAMU HASTANE BİRLİĞİ: 3030 ton coal procur.**
Tender reg.no : **2017/447292**
Bid deadline : 17.10.2017
Approx. Cost : 1.951.471,50 TL
Quoting 1.836.210,00 TL, **BİRCANLAR MADENCİLİK TİC.VE SAN. LTD.ŞTİ.** received the contract.
- **MARDİN M.MUNICIPALITY : Explosives procur.**
Tender reg.no : **2017/175728**
Bid deadline : 14.04.2017
Approx. Cost : 2.693.701,40 TL
Quoting 2.495.052,00 TL **MİDYAT PATLAYICI MAD. SAN. A.Ş.** received the contract.
- **MUĞLA-MUSKİ ADMINISTRATION :**
Tender reg.no : **2016/576344**
Bid deadline : 25.01.2017
4.item (For drinking water treatment plants Ferrous III Chloride Type- 1, Class 1, Gas chloride Type- 1)
Winner : **AYKİMSAN HİÇYILMAZ LTD.**
Approx. Cost : 2.385.100,00 TL
Contract cost : 455.250,00 TL
5. item (For drinking water treatment plants Sodium Hydroxide solution Type- 1)
Winner : **AYKİMSAN HİÇYILMAZ LTD.**
Approx. Cost : 154.400,00 TL
Contract cost : 152.000,00 TL
6.Kısım (For waste water treatment plants Ferrous III Chloride. type 2)
Winner : **AYKİMSAN HİÇYILMAZ LTD.**
Approx. Cost : 146.010,00 TL
Contract cost : 139.500,00 TL
8.Kısım (Cationic Polyelectrolide)
Winner : **ABACI KİMYA LTD.**
Approx. Cost : 539.000,00 TL
Contract cost : 427.350,00 TL

- **RİZE ÖZEL İDARESİ**; Various explosives and ignition materials
Tender reg.no : **2017/348674**
Bid deadline : 25.07.2017
Approx. Cost : 94.553,50 TL
Quoting 92.257,00 TL, **ATAMANLAR PATLAYICI MADDE LTD.ŞTİ.** received the contract.
- **SAKARYA M.MUNICIPALITY** : 3.500 ton salt procur..
Tender reg.no : **2017/348107**
Bid deadline : 10.08.2017
Approx. Cost : 455.000,00 TL
Quoting 392.000,00 TL, **BİNBİR GIDA TARIM ÜRÜN. SAN. A.Ş.** received the contract.
- **SİNOP İL ÖZEL İDARESİ**: 10 Items explosives and fuses.
Tender reg.no : **2017/397970**
Bid deadline : 21.08.2017
Approx. Cost : 68.966,00 TL
Quoting 72.371,50 TL, **KAPEKS ÜRETİM PATLAYICI MADDELER TİCARET LTD** received the contract.
- **STATE SUPPLY OFFICE (TMO)**: Import of corn, barley and paddy (**DETAY-1553-1552**)
Bid method : Invitation
Bid deadline : 21-22.11.2017
Corn tender:
İzmir Port , 712.50 TL/mt, C&F, **ERSER TARIM**, (2 x 12.6 thousand Ton)
İzmir Port , 715 TL/mt, C&F, **CARGİLL**, (12.55 thousand Ton)
Bandırma Port , 707.50 TL/mt, **SOLARİS**, (2 x 12.69 thousand Ton)
Antalya Port , 714 TL/mt, C&F, **KULBERG**, (4 x 12.58 thousand Ton)
Layday : 27 Nov. 2017/10 Dec. 2017
The other bidders;
- **TİRYAKİ AGRO**
- **ADM**
- **VA INTERTRADING**
Barley Tender:
Bid deadline : 22.11.2017
- Mersin Port , 860 TL/mt, C&F, **GLENCORE**, (12.000 Ton)
- İskenderun Port , 870 TL/mt C&F, **GLENCORE**, (12.000 Ton)
- İzmir Port , 842,50 TL/mt, **DREYFUS**, (12.000 Ton)
- Trabzon Port , 849 TL/mt, C&F, **ADM**, (12.000 Ton)
Corn imports:
6x 12.000 mton for Derince 708 TL
Winner : **TİRYAKİ AGRO**
2x 12.000 mton for Derince 709 TL
Winner : **ERSER TARIM**
In paddy and rice tenders, 7000 mton paddy price 2440 TL and 5000 mton rice.
No procurement of paddy was made with the tender held on 24 Nov. 2017.
- **STATE SUPPLY OFFICE (TMO)**: For Trabzon Branch Müdürlüğü, fodder barley to be unloaded at Trabzon Port
Bid method : 4734 / 3-g
Tender reg.no : **2017/443521**
Bid deadline : 11.10.2017
Approx. Cost : 8.980.120,00 TL
Quoting 8.979.145,35 TL, **ULUSOY UN SAN. A.Ş.** received the contract. .
- **STATE SUPPLY OFFICE (TMO)**: Fodder barley to be unloaded at Trabzon Port
Bid method : 4734 / 3-g / Auction
Tender reg.no : **2017/443521**
Bid deadline : 11.10.2017
Approx. Cost : 8.980.120,00 TL
Quoting 8.979.145,35 TL, **ULUSOY UN SAN. A.Ş.** received the contract. .
- **STATE SUPPLY OFFICE (TMO)**: For Afyonkarahisar Branch Müdürlüğü, fodder barley imports to be unloaded at İzmir Port
Tender reg.no : **2017/136749**
Bid deadline : 23.03.2017
Winner : **ULUSOY UN SANAYİ A.Ş**
Approx. Cost : 8.980.120,00 TL
Contract cost : 8.424.000,00 TL
- **STATE SUPPLY OFFICE** :Fodder barley imports to be unloaded at Bandırma Port
Tender reg.no : **2017/136736**
Bid deadline : 23.03.2017
Winner : **TİRYAKİ AGRO SAN A.Ş**
Approx. Cost : 8.980.120,00 TL
Contract cost : 8.978.082,50 TL
- **STATE SUPPLY OFFICE** : For Eskişehir Branch Müdürlüğü, to be unloaded at Bandırma Port
Tender reg.no : **2017/136739**
Bid deadline : 23.03.2017
Winner : **TİRYAKİ AGRO SAN A.Ş**
Approx. Cost : 8.980.120,00 TL
Contract cost : 8.978.082,50 TL
- **STATE SUPPLY OFFICE** :Fodder barley to be unloaded at İskenderun Port
Tender reg.no : **2017/136752**
Bid deadline : 23.03.2017
Winner : **ULUSOY UN SANAYİ A.Ş**
Approx. Cost : 8.980.120,00 TL
Contract cost : 8.875.000,00 TL
- **STATE SUPPLY OFFICE** : fodder barley imports to be unloaded at İzmir Port
Tender reg.no : **2017/136744**
Bid deadline : 23.03.2017
Winner : **GLENCORE AGRICULTRE**
Approx. Cost : 8.980.120,00 TL
Contract cost : 8.978.655,00 TL

- **STATE SUPPLY OFFICE : For Mersin Branch Müdürlüğü**
fodder barley imports to be unloaded at İskenderun Port
Tender reg.no : **2017/136755**
Bid deadline : 23.03.2017
Winner : **ULUSOY UN SAN A.Ş**
Approx. Cost : 8.980.120,00 TL
Contract cost : 8.875.000,00 TL
 - **STATE SUPPLY OFFICE : Fodder barley imports to be unloaded at Samsun Port**
Tender reg.no : **2017/136710**
Bid deadline : 23.03.2017
Winner : **VA INTERTRADING AKTIENGESELLSCHAFT**
Approx. Cost : 8.980.120,00 TL
Contract cost : 8.977.500,00 TL
 - **STATE SUPPLY OFFICE : Fodder barley imports to be unloaded at Trabzon Port**
Tender reg.no : **2017/136722**
Bid deadline : 23.03.2017
Winner : **ADM INTERNATIONAL SARL**
Approx. Cost : 8.980.120,00 TL
Contract cost : 8.162.000,00 TL
 - **STATE SUPPLY OFFICE : For EU-origin wheat, tenders were held on 8 March 2017 and 3 firms received the contract as follows:**
 - **10.000 mt (+20%)**
Winner : **ANAGRO (ANGORAM)**
3rd round offer : 833 TL
Branch : Mersin
 - **10.000 mt (+20%)**
Winner : **ANAGRO (ANGORAM)**
3rd round offer : 833 TL
Branch : Konya
 - **10.000 mt (+20%)**
Winner : **ANAGRO (ANGORAM)**
3rd round offer : 833 TL
Branch : Gaziantep
 - **10.000 mt (+20%)**
Winner : **ANAGRO (ANGORAM)**
3rd round offer : 833 TL
Branch : Aksaray
 - **10.000 mt (+20%)**
Winner : **ANAGRO (ANGORAM)**
3rd round offer : 833 TL
Branch : Polatlı
 - **10.000 mt (+20%)**
Winner : **ADM**
3rd round offer : 837,50 TL
Branch : İzmir
 - **10.000 mt (+20%)**
Winner : **ADM**
3rd round offer : 837,50 TL
Branch : Denizli
 - **10.000 mt (+20%)**
Winner : **ADM**
3rd round offer : 837,50 TL
Branch : Afyon
 - **10.000 mt (+20%)**
Winner : **HAKAN AGRO**
3rd round offer : 848 TL
Branch : Bandırma
 - **10.000 mt (+20%)**
Winner : **HAKAN AGRO**
3rd round offer : 848 TL
Branch : Eskişehir
 - **10.000 mt (+20%)**
Winner : **HAKAN AGRO**
3rd round offer : 860 TL
Branch : Tekirdağ
 - **10.000 mt (+20%)**
Winner : **HAKAN AGRO**
3rd round offer : 877 TL
Branch : Samsun
 - **10.000 mt (+20%)**
Winner : **HAKAN AGRO**
3rd round offer : 877 TL
Branch : Trabzon
- The other bidders;
- **CARGILL**
 - **GLENCORE**
 - **ULUSOY**
 - **DREYFUS**
- **TURKISH SUGAR MILLS ENTERPRISE (TSF):**
43.000 ton metallurgical coke procurement
Bid method : Open
Tender reg.no : **2017/188124**
Bid deadline : 02.06.2017
Approx. Cost : 60.616.782,66 TL
Winner : **ATAKAŞ TİC VE NAK. A.Ş.**
Contract cost : 498.000,00 TL
Winner : **AKABE MAD. SAN. TİC.A. Ş.**
Contract cost : 30.262.200,00TL
Winner : **YILYAK YAKIT PAZ. TİC.A. Ş.**
Contract cost : 20.821.280,00 TL
 - **TURKISH COAL WORKS MANAGEMENT (TKİ) –**
Various explosives procurement, transport and charging into hollows and exploding services at E.L.İ.Müessesesi Müdürlüğü Soma, Deniz and Eynes open Stone quarries
Bid method : Open
Tender reg.no : **2017/233705**
Bid deadline : 15.06.2017
Approx. Cost : 8.882.800,00 TL
Quoting 4.833.750,00 TL, **NİTROMAK A.Ş.** received the contract.
 - **AKSARAY MUNICIPALITY – Aluminium sulphate and sulphuric acid procurement**
Bid method : Open
Tender reg.no : **2017/486619**
Bid deadline : 15.06.2017
Approx. Cost : 440.940,00 TL.
Quoting 323.700,00 TL, **HİCRİ ERCİLİ DENİZ NAKLİYAT KİMYEVİ MAD. LTD.** received the contract.

TRANSPORT TENDER RESULTS

- **ETİ MADEN İŞLETMELERİ GENEL MÜDÜRLÜĞÜ**
Lojistik Dairesi Başkanlığı: 3690,32 tons
Immingham shipping. (Boron products)
Tender reg.no : **17ESA / 339**
Bid deadline : 26.10.2017
Loading Port : Bandırma (Turkey)
Unloading Port : Immingham/UK
Layday : 01 Nov. -05 Nov. 2017
Importer:
John Good and Sons (Shipping) Ltd
Innovation Centre Europarc
DN37 9TT, Grimsby
North East Lincolnshire United Kingdom
- **ETİ MADEN İŞLETMELERİ GENEL MÜDÜRLÜĞÜ**
Lojistik Dairesi Başkanlığı: 2500 tons Tarragona
shipping((Boron products)
Tender reg.no : **17ESA / 323**
Bid deadline : 26.10.2017
Loading Port : Bandırma (Turkey)
Unloading Port : Tarragona/Spain
Layday : 09 Nov. -10 Nov. 2017
Importer:
Alfashipping International Sa
Apodaca Street No.5 Esca, 1st floor 43004 Tarragona,
Spain
- **ETİ MADEN İŞLETMELERİ GENEL MÜDÜRLÜĞÜ**
Lojistik Dairesi Başkanlığı: 5101.20 tons Constantza
shipping (Boron products)
Tender reg.no : **ESA / 321**
Bid deadline : 27.10.2017
Loading Port : Bandırma (Turkey)
Unloading Port : Constantza/Romania
Layday : 06 Nov. -10 Nov. 2017
Importer:
IDU Shipping and Services SRL 182, Mamaia Avenue
900540 Constantza / Romania
- **ETİ MADEN İŞLETMELERİ GENEL MÜDÜRLÜĞÜ**
Lojistik Dairesi Başkanlığı: 3120.80 tons Azov
shipping (Boron products)
Tender reg.no : **EPR / 016**
Bid deadline : 27.10.2017
Loading Port : Bandırma (Tur.) Çelebi (Tur.)
Unloading Port : Azov/Obuhovka term.
(Russia)
Layday : 01 Nov.-5 Nov. 201
- **ETİ MADEN İŞLETMELERİ GENEL MÜDÜRLÜĞÜ**
Lojistik Dairesi Başkanlığı: 5251 tons Constantza
shipping. (Boron products)
Tender reg.no : **17ESA / 408**
Bid deadline : 24.11.2017
Loading Port : Bandırma (Turkey)
Unloading Port : Constantza/ Romania
Layday : 01 Nov. -05 Dec.2017
Importer:IDU Shipping and Services SRL 182,
Mamaia Avenue Romania
- **ETİ MADEN İŞLETMELERİ GENEL MÜDÜRLÜĞÜ**
Lojistik Dairesi Başkanlığı: 2970 tons Avov
shipping. (Boron products)
Tender reg.no : **EPR / 020**
Bid deadline : 24.11.2017
Loading Port : Bandırma (Turkey)
Unloading Port : Azov/Obuhovka
Layday : 27-30 Nov. 2017
- **ETİ MADEN İŞLETMELERİ GENEL MÜDÜRLÜĞÜ**
Lojistik Dairesi Başkanlığı: 3075 tons Azov
shipping.
Tender reg.no : **17EPR / 019**
Bid deadline : 10.10.2017
Loading Port : Bandırma Terminal/ Çelebi
Turkey)
Unloading Port : Azov/ Obuhovka Terminal
(Ukraine)
Layday : 16-19 Oct. 2017
Importer:
DORDRECHT
Gans Transport BV
Ravelstraat 5, 3161 WE Rhoon, Netherlands
UDDEVALLA
- **ETİ MADEN İŞLETMELERİ GENEL MÜDÜRLÜĞÜ**
Lojistik Dairesi Başkanlığı: 9342 tons Terneuzen
shipping.
Tender reg.no : **ESA / 306**
Bid deadline : 11.10.2017
Loading Port : Bandırma (Turkey)
Unloading Port : Terneuzen/NL
Layday : 18-24 Oct. 2017
Importer:
VERBRUGGE MARINE B.V.
Zwedenweg 1, Port Number 1361
NI-4530 Aa, Terneuzen
The Netherlands
- **ETİ MADEN İŞLETMELERİ GENEL MÜDÜRLÜĞÜ**
Lojistik Dairesi Başkanlığı: 3016,80 tons Azov
shipping.
Tender reg.no : **17EPR / 013**
Bid deadline : 22.9.2017
Loading Port : Bandırma/Çelebi
Unloading Port : Azov/Obuhovka Terminal
Layday : 27 Sep. -29 Sep. 2017
1050 tons KIR Etibor-48 in 1000 kg PP+PE big bags,
500 tons EME 2.Plant NS granular Boric Acid in 1000
kg PP+PE big bags,
500 tons BIG Ground Colemanite (-75 micron) in 1000
kg PP+PE big bags,
500 tons BIG Ground Ulexite (-75 micron) in 1000 kg
PP+PE big bags
315 tons BIG Ground Ulexite (-75 micron) in 25 kg
LAM PP bags on 1050 kg slings bag without pallets,
150 tons BIG Ground Ulexite (-45 micron) in 1000 kg
baffle big bags,
1,8 tons BAN Boron Oxid in 25 kg on 600 kg pallets,

- **ETİ MADEN İŞLETMELERİ GENEL MÜDÜRLÜĞÜ:**
Lojistik Dairesi Başkanlığı: 4932 ton Dordrecht, Szczecin shipping.
Bid deadline : 15.3.2017
Tender reg.no : **17EPO / Y-03**
Boron products
Loading Port : Bandırma
Unloading Port : Dordrecht/NL
Layday : 20-24 March 2017
Loaded Qty : 3300 (+-5% opt.)
Boron products
Loading Port : Bandırma
Unloading Port : Szczecin/Pol
Layday : 20-24 March 2017
Loaded Qty : 1632 (+-5% opt.)
- **ETİ MADEN İŞLETMELERİ GENEL MÜDÜRLÜĞÜ:**
Lojistik Dairesi Başkanlığı: 6203.40 tons Dordrecht, Uddevalla shipping.
Tender reg.no : **EPOY / 147**
Bid deadline : 12.10.2017
Loading Port : Bandırma (Turkey)
Unloading Port :Dordrecht (TheNetherlands)
Layday : 24-28 Oct. 2017
Qty :3.490.40 (+/-%5 Eti option)
Loading Port : Bandırma (Turkey)
Unloading Port :Uddevalla (Swenden)
Layday : 24-28 Oct. 2017
Qty :2.713.00 (+/-5% Eti option)
İmporter:
DORDRECHT
Gans Transport BV Ravelstraat 5, 3161 WE Rhooon,
Netherlands
Tel:+31 10 50 134 55 Fax:+31 10 50 125 43
- **ETİ MADEN İŞLETMELERİ GENEL MÜDÜRLÜĞÜ:**
Lojistik Dairesi Başkanlığı: 4250 tons Immingham shipping (Boron products)
Tender reg.no : **17ESA / 288**
Bid deadline : 19.9.2017
Loading Port : Bandırma
Unloading Port : Immingham/UK
Layday : 21 Sep. -24 Sep. 2017
İmporter:
JOHN GOOD AND SONS (SHİPPİNG) LTD
Innovation Centre Europarc
DN37 9TT, Grimsby
North East Lincolnshire
United Kingdom
Phone +44 1472 722409
- **ETİ MADEN İŞLETMELERİ GENEL MÜDÜRLÜĞÜ:**
Lojistik Dairesi Başkanlığı: 3500 ton Koper shipping
3500.00 tons Etibor-48 (P1758480) in bulk, (+/- 5% tolerance)
Tender reg.no : **17ESA / 286**
Bid deadline : 19.9.2017
Loading Port : Bandırma
Unloading Port : Koper/Slovenia
Layday : 25 Sep. -26 Sep. 2017
İmporter:
ADRIA CARGO KOPER D.O.O.
Pristaniska 8, PO Box 267
6000 Koper Slovenia
Tel: 00386 5 663 4130
- **ETİ MADEN İŞLETMELERİ GENEL MÜDÜRLÜĞÜ:**
Lojistik Dairesi Başkanlığı: 2500 tons Tarragona shipping.
Tender reg.no : **17ESA / 287**
Bid deadline : 19.9.2017
Loading Port : Bandırma
Unloading Port : Tarragona / Spain
Layday : 27 Sep. -28 Sep. 2017
İmporter:
ALFASHİPPİNG INTERNATİONAL SA
Apodaca Street No.5 Esca, 1st floor 43004 Tarragona
Spain
Tel: +34 977 21 88 02
- **ETİ MADEN İŞLETMELERİ GENEL MÜDÜRLÜĞÜ:**
Lojistik Dairesi Başkanlığı: 2017/32-2. Hafta CIF, CIP, CFR Esaslı 2 TRANS. 636 TEU Services
Tender reg.no : **17ESA / 287**
Bid deadline : 11.08.2017
Loading Port : Bandırma
Unloading Port : CHONGQING, SHANGHAI, HUANGPU PORT, QINGYUAN, ILFOV, CRAIOVA, DALIAN PORT, TIANJIN, BUSAN PORT
Layday : 28.08.2017
- **ETİ MADEN İŞLETMELERİ GENEL MÜDÜRLÜĞÜ:**
Lojistik Dairesi Başkanlığı: 5314.00 tons Szczecin shipping. (3500 tons KIR Etibor-48 in bulk,700 tons BAN Boric Acid in bulk,Total 4314.00 tons (+/- 5% option)
Tender reg.no : **EPOY / 063**
Bid deadline : 5.5.2017
Loading Port : Bandırma/Turkey
Unloading Port : SZCZECIN/POL
Layday :15-18 May 2017
İmporter:
FAST BALTIC SP. Z O.O. Ul. Bytomska 7, 70-603
Szczecin, Poland Tel : +48 91 4308-550
- **ETİ MADEN İŞLETMELERİ GENEL MÜDÜRLÜĞÜ:**
Lojistik Dairesi Başkanlığı: 2500 ton Tarragona taşıması (2500 tons Etibor-48 (P1758238) in bulk (+/- 5% option)
Tender reg.no : **17ESA / 143**
Bid deadline : 5.5.2017
Loading Port : Bandırma/Turkey
Unloading Port : Tarragona/Spain
Layday : 8-9 Mayıs 2017
İmporter:
ALFASHİPPİNG INTERNATİONAL SA
Apodaca Street No.5 Esca, 1st floor 43004 Tarragona,
Spain Tel: +34 977 21 88 02
- **ETİ MADEN İŞLETMELERİ GENEL MÜDÜRLÜĞÜ:**
Lojistik Dairesi Başkanlığı: 4620ton Dordrecht & Uddevalla shipping (Tender reg.no: 17EPO / 086)
Bid deadline : 30.06.2017
Product : Boron products
Loading Port : Bandırma
Unloading Port : Dordrecht (The Netherlands)
Qty : 2312 ton (+-5% Eti Ops.)
Layday : 10-14 July 2017
Cinsi : Boron products
Loading Port : Bandırma
Unloading Port : Uddevalla (Sweden)
Qty : 2308 ton (+-5% Eti Ops.)
Layday : 10-14 July 2017

- **ETİ MADEN İŞLETMELERİ GENEL MÜDÜRLÜĞÜ**
Lojistik Dairesi Başkanlığı: 4500 tons Immingham shipping (4500.000 tons (+/-5% ETİ's option)
Tender reg.no : **17ESA / 159**
Bid deadline : 5.5.2017
Loading Port : Bandırma/Turkey
Unloading Port : Immingham/UK
Layday : 10-14 May 2017
İmporter:
JOHN GOOD AND SONS (SHIPPING) LTD,
Innovation Centre Europarc DN37 9TT, Grimsby North
East Lincolnshire
United Kingdom Phone +44 1472 722409
- **ETİ MADEN İŞLETMELERİ GENEL MÜDÜRLÜĞÜ:**
Lojistik Dairesi Başkanlığı: 3888 tons Ravenna shipping.
Bid deadline : **16.3.2017**
Tender reg.no : 17ESA / 101
Loading Port : Bandırma
Unloading Port : Tarragona/Spain
Layday : 22-24 March 2017
Loaded Qty : 3888 (+5% opt.)
- **ETİ MADEN İŞLETMELERİ GENEL MÜDÜRLÜĞÜ:**
90.000 ton tıncal ore transports from Kırka to Bandırma Bor ve Asit Fabrikaları İşletme Müdürlüğü storage areas and 90.000 ton tıncal ore transports from Kırka to Değirmenözü loading facilities
Tender reg.no : **2017/491908**
Bid deadline : 16.10.2017
Winner : **MİRAP ULUSL. NAK. A.Ş.**
Approx. Cost : 4.727.481,00 TL
Contract cost : 4.065.300,00 TL
- **ETİ MADEN İŞLETMELERİ GENEL MÜDÜRLÜĞÜ:**
850.000 ton sludge and coal ash transports .
Tender reg.no : **2017/461718**
Bid deadline : 06.10.2017
Winner : **MAKSİMUM LOJİSTİK A.Ş.**
Approx. Cost : 5.930.187,98 TL
Contract cost : 5.737.500,00 TL
- **ETİ MADEN İŞLETMELERİ GENEL MÜDÜRLÜĞÜ:** **From open Stone quarries 3.500.000 tuvenane ore transports and at concentrator facilities ore preparation**
Tender reg.no : **2017/402870**
Bid deadline : 14.10.2017
Winner : **ALP SOSYAL HİZ. LTD ŞTİ**
Approx. Cost : 35.886.256,40 TL
Contract cost : 34.909.466,50 TL
- **ETİ MADEN İŞLETMELERİ GENEL MÜDÜRLÜĞÜ:**
From Kırka Bor İşletme Müdürlüğü Kırka-Sevittazı/ Eskişehir 2.910.000 ton tuvenane ore and excavated debris transports, ore transports to factories and feeding services coal stacking, waste ash transports, 800.000 ton solid waste transports
Tender reg.no : **2017/141268**
Bid deadline : 10.04.2017
Winner : **MAKSİMUM LOJİSTİK A.Ş.**
Approx. Cost : 7.473.611,82 TL
Contract cost : 7.143.500,00 TL
- **ETİ MADEN İŞLETMELERİ GENEL MÜDÜRLÜĞÜ:**
From Kırka Bor İşletme Müdürlüğü 350000 ton tıncal ore transports
Tender reg.no : **2017/49822**
Bid deadline : 24.03.2017
Winner : **SİTE LOJİSTİK A.Ş.**
Approx. Cost : 5.565.425,00 TL
Contract cost : 3.649.500,00 TL
- **ETİ MADEN İŞLETMELERİ GENEL MÜDÜRLÜĞÜ:**
2018 Inspection and Supervision Services (01.07.2017-30.06.2018 period)
Tender reg.no : Direct invitation
Winner : **TÜRK STANDARTLARI ENSTİTÜSÜ (TSE)**
Contract cost : 5.895.601,00
- **SAMSUN METROPOLİTAN MUNICIPALITY:** **From asphalt production plants to various streets 150.000 ton BSK and 350.000 Ton PMT transports.**
Tender reg.no : **2017/482983**
Bid deadline : 06.11.2017
Winner : **BAŞ İNŞAAT LTD.ŞTİ.**
Approx. Cost : 4.745.000,00 TL
Contract cost : 4.137.000,00 TL
- **ORDU METROPOLİTAN MUNICIPALITY:** **5.000 ton bitumenous materials from TÜPRAŞ Kırıkkale Refinery to Altınordu's Karapınar , Kayabaşı Plants and Fatsa Facilities.**
Tender reg.no : **2017/409961**
Bid deadline : 13.10.2017
Winner : **MAHMUT ORAK**
Approx. Cost : 415.000,00 TL
Contract cost : 387.500,00 TL
- **TKİ EGE LİNYİTLERİ İŞLETMESİ:** **From Dereköy storage areas 450.000 ton coal loading and transports to Soma Thermal P.Plant Units 1 - 4 (Balcıkapı - Yırcakap unloading points) and units 5-6**
Tender reg.no : **2017/343502**
Bid deadline : 02.08.2017
Winner : **S.S. SOMA TAŞ. KOOP.**
Approx. Cost : 4.051.346,00 TL
Contract cost : 3.780.000,00 TL
- **TKİ EGE LİNYİTLERİ İŞLETMESİ:** **From Eynez Yeraltı Kontrol Şube Müdürlüğü storage areas. 450.000 ton coal transports to Soma B P.Plant units 1-4, Yırca Kapı**
Tender reg.no : **2017/340764**
Bid deadline : 01.08.2017
Winner : **S.S. SOMA TAŞ. KOOP.**
Approx. Cost : 4.096.956,25 TL
Contract cost : 4.162.500,00 TL
- **TKİ EGE LİNYİTLERİ İŞLETMESİ:** **From Eynez Yeraltı Kontrol Şube Müdürlüğü's storage areas 500.000 ton coal transports to Soma B Thermal P.Plant units 1-4 Yırca Gate and units 5-6**
Tender reg.no : **2017/183187**
Bid deadline : 04.05.2017
Winner : **S.S. SOMA TAŞ. KOOP.**
Approx. Cost : 4.336.789,00 TL
Contract cost : 4.625.000,00 TL.

- **TKİ EGE LİNYİTLERİ İŞLETMESİ:** From Dereköy Lavvar Tesisi silos 900.000 ton + 18 mm coals and 0.5-10 mm coals to be transported and unloaded and from Dereköy Lavvar Tesisi silos 900.000 ton mixed materials and 0.1-0.5 mm coal
 Tender reg.no : **2017/227831**
 Bid deadline : 26.05.2017
 Winner : **YUTA ÇALIŞKAN LOJ. LTD.**
 Approx. Cost : 1.516.120,75 TL
 Contract cost : 1.620.000,00 TL

- **TKİ EGE LİNYİTLERİ İŞLETMESİ:** Transport of 39.950 ton coals to Manisa and districts and unloading services
 Tender reg.no : **2018/227831**
 Winner : **SINIRLI SORUMLU SOMA NAKLİYECİLER MOTORLU TAŞIYICILAR KOOPERATİFİ.**
 Approx. Cost : 1.512.944,25 TL
 Contract cost : 1.478.150,00 TL

- **NATIONAL DEFENSE MINISTRY- 11.İKMAL MERKEZ KOMUTANLIĞI (ANKARA)** From Ankara to Prizren/Kosovo construction machine transports.
 Tender reg.no : **2017/461718**
 Bid deadline : 15.08.2017
 Winner : **ALP ÖZLER NAKLİYAT**
 Approx. Cost : 147.761,99 TL
 Contract cost : 86.800,00 TL

- **STATE HIGHWAYS AUTHORITY 1. BÖLGE MÜDÜRLÜĞÜ:** From İzmit Refinery and KGM 1.Bölge Müdürlüğü asphalt depots to fixed asphalt depot tanks 30.000 ton bitumenous materials to be transported .
 Tender reg.no : **2017/17979**
 Bid deadline : 08.03.2017
 Winner : **GÜRBAĞ LOJİSTİK LTD ŞTİ.**
 Approx. Cost : 1.315.778,96 TL
 Contract cost : 1.440.000,00 TL

- **STATE HIGHWAYS AUTHORITY 7. BÖLGE MÜDÜRLÜĞÜ:** 15.000 ton bitumenous materials to be transported to regional storage plants
 Tender reg.no : **2017/155958**
 Bid deadline : 11.05.2017
 Winner : **DIYARBAKIR DOLUNAY PET.**
 Approx. Cost : 1.065.150,00 TL
 Contract cost : 929.850,00 TL

- **ANTALYA METROPOLİTAN MUNICIPALITY:** 5000 ton bitumenous materials from TÜPRAŞ Refineries.
 Tender reg.no : **2017/98392**
 Bid deadline : 29.03.2017
 Winner : **YÖRÜKOĞLU PET. LTD.ŞTİ**
 Approx. Cost : 581.250,00 TL
 Contract cost : 495.000,00 TL

- **SAKARYA METROPOLİTAN MUNICIPALITY:** Bitumenous materials to be transported.
 Tender reg.no : **2017/571251**
 Winner : **SAYHAN PETROL İNŞ. LTD.**
 Approx. Cost : 651.350,00 TL
 Contract cost : 602.000,00 TL

- **STATE HIGHWAYS AUTHORITY- 10. BÖLGE MÜDÜRLÜĞÜ:** From Tüpraş Refineries to KGM 10.Bölge Müdürlüğü depots 25.000 ton bitumenous materials to be transported .
 Tender reg.no : **2017/257078**
 Bid deadline : 30.06.2017
 Winner : **ŞEKER PETROL LTD.**
 Approx. Cost : 3.221.750,00 TL
 Contract cost : 3.190.000,00 TL

- **STATE HIGHWAYS AUTHORITY 13. BÖLGE MÜDÜRLÜĞÜ:** 17.000 ton bitumenous materials to be transported.
 Tender reg.no : **2017/150933**
 Bid deadline : 11.05.2017
 Winner : **GÜNDEM PETROL LTD**
 Approx. Cost : 1.672.800,00 TL
 Contract cost : 1.593.750,00 TL

- **STATE HIGHWAYS 14. BÖLGE MÜDÜRLÜĞÜ:** İzmit and İzmir (Aliağa) Refineries to KGM 14 Bölge Müdürlüğü fixed asphalt depot 17.000 ton bitumenous materials to be transported.
 Tender reg.no : **2017/58003**
 Bid deadline : 07.03.2017
 Winner : **ŞARK KİMYA SAN LTD**
 Approx. Cost : 913.838,75 TL
 Contract cost : 884.000,00 TL

- **TEKİRDAĞ METROPOLİTAN MUNICIPALITY:** Between İzmit Tüpraş Refinery and Tekirdağ 9.500 ton bitumenous materials to be transported.
 Tender reg.no : **2017/224952**
 Bid deadline : 06.06.2017
 Winner : **BARIŞYOL PETROL + KOFAN PETROL LTD.ŞTİ**
 Approx. Cost : 649.610,00 TL
 Contract cost : 646.000,00 TL

- **KAYSERİ METROPOLİTAN MUNICIPALITY:** 1.250.000 ton debris.foundation materials and asphalt materials transports.
 Tender reg.no : **2017/97642**
 Bid deadline : 04.04.2017
 Winner : **OĞUZHAN ULUSL TİC. LTD**
 Approx. Cost : 8.609.665,00 TL
 Contract cost : 6.660.900,00 TL

- **ELECTRICITY GENERATION CO. (EÜAŞ):** 6.126-Ton no 3 Fuel-Oil transports to Afşin-Elbistan B P.Plant İşletme Müdürlüğü depots from Doğu Karadeniz ve Yöresi İşletme Müdürlüğü fuel tanks.
 Tender reg.no : **2017/29767**
 Bid deadline : 21.03.2017
 Winner : **OĞUZHAN ULUSL TİC. LTD**
 Approx. Cost : 1.189.218,33 TL
 Contract cost : 1.163.940,00 TL

MACHINERY & EQUIPMENT TENDER RESULTS

- **MUŞ MUNICIPALITY:** 1 ea fire fighting vehicle with 42 m. convent. hydro ladder.
 Bid Method : Open
 Tender Reg.No : 2016/522933
 Bid Deadline : 29.12.2016
 Approx. Cost : 2.663.805,44 TL
 Winner : **VOLKAN İTFAİYE A.Ş.**
 Contract cost : 2.045.000,00 TL
- **ÇANAKKALE MUNICIPALITY:** Ductile pipes and fittings.
 Bid Method : Open
 Tender Reg.No : **2016/477835**
 Bid Deadline : 16.12.2016
 Approx. Cost : 1.748.482,81 TL
 Winner : **SAMSUN MAKİNE SAN. A.Ş**
 Contract cost : 1.709.767,00 TL
- **ADNAN MENDERES UNIVERSITY (ADÜ)** 1 ea emergency ambulance
 Bid Method : Open
 Approx. Cost : 175.000,00 TL
 Winner : **AMBULANS İLKYARDIM A.Ş.**
 Contract cost : 187.870,00 TL
- **KASTAMONU MUNICIPALITY:** 3 types of fire fighting vehicles
 Bid Method : Open
 Tender Reg.No : **2016/532006**
 Bid Deadline : 10.01.2017
 Approx. Cost : 3.818.000,00 TL
 Partial App.Cost : 1.411.333,33 TL
 Winner : **VOLKAN İTFAİYE A.Ş.**
 Contract cost : 1.160.000,00 TL
- **MANİSA METROPOLITAN MUNICIPALITY:** 5 ea trailers (Tır 4x2)
 Bid Method : Open
 Tender Reg.No : **2017/4283**
 Bid Deadline : 02.02.2017
 Approx. Cost : 1.575.250,00 TL
 Winner : **BÜYÜKKARCI OTOMOTİV (Ford)**
 Contract cost : 1.600.000,00 TL
- **TCDD GENERAL DIRECT.** : 10 ea high speed trains
 Bid Method : Auction
 Bid Deadline : 30.01.2017
 3 firms submitted bids for procurement financed by the İDB. Cheapest bid 273.257.433 euro was quoted by **Spain's CAF** followed by an offer of 349.345.401 euro quoted by **SIEMENS AG-SIEMENS AŞ. (DETAY-1513)**
- **BOTAŞ GENERAL DIRECT.** : Steel pipes for Hakkari naturalgas pipeline constr.
 Bid Method : Open
 Tender Reg.No : **2016/590136**
 Bid Deadline : 15.02.2017
 Approx. Cost : 40.384.063,47 TL
 Winner : **EMEK BORU+NOKSEL BORU+ERCİYAS BORU+ÜMRAN BORU**
 Contract cost : 38.795.177,00 TL
- **İZMİR METROPOLITAN MUNICIPALITY:** 5 Items of fire fighting /rescue vehicles (7 ea)
 Bid Method : Open
 Tender Reg.No : **2016/136734**
 Bid Deadline : 30.12.2016
 Tot. Approx. Cost . :25.811.500,00 TL
Ordered items:
 - **1. İtem :** 3 Ea fire fighting vehicles (27 mt. narrow area ladder combi)
 App.Cost under Contract : 10.158.754,32 TL
 Contract date : 03.01.2017
 Contract cost : 2.959.260,00 EUR
 Winner : **ROSENBAUER INT. AG (Austria)**
 - **2. İtem :** 1 ea mountain search and rescue vehicle
 - **3. İtem :** 1 ea water search and rescue vehicle
 App.Cost under Contract : 6.803.585,36 TL
 Contract date : 06.12.2016
 Contract cost : 1.990.200,00 EUR
 Winner : **ROSENBAUER INT. AG (Austria)**
 - **4. İtem :** 1 ea Command control vehicle (special design *Afet İskan*)
 App.Cost under Contract : 5.658.750,24 TL
 Contract date : 24.11.2016
 Contract cost : 1.980.000,00 EUR
 Winner : **A.D.R. OTOMOTİV LTD**
 - **5. İtem :** 1 ea filling device (breathing machine)
 App.Cost under Contract : 3.190.410,08 TL
 Contract date : 13.12.2016
 Contract cost : 944.540,00 EUR
 Winner : **ROSENBAUER INT. AG (Austria)**
- **ADANA METROPOLITAN MUNICIPALITY:** 15 ea water sprinklers
 Tender Reg.No : **2016/522933**
 Bid Deadline : 09.01.2017
 Approx. Cost : 4.625.000,00 TL
 Winner : **KATMERCİLER A.Ş.**
 Contract cost : 4.225.000,00 TL
- **SANLIURFA METROPOLITAN MUNICIPALITY:** 25 ea 12 m. solo type diesel, 20 ea 18 m. articulated diesel buses. Total 45 ea Buses
 Bid Method : Open
 Tender Reg.No : **2016/567394**
 Bid Deadline : 16.01.2017
 Approx. Cost : 30.440.056,40 TL
1.İTEM (20 ea 18 mt.)
 Winner : **KARSAN OTOMOTİV A .Ş.**
 Approx. Cost : 17.966.838,40 TL
 Contract cost : 15.699.000,00 TL
2.İTEM (25 ea 12 mt.)
 Winner : **TEMSA A .Ş.**
 Approx. Cost : 12.473.218,00 TL
 Contract cost : 11.200.000,00 TL

- **BOTAS GENERAL DIRECT. : 2 item of steel pipes and fittings for Elazığ drinking water main lines (11.8 km.section)**
Tender Reg.No : **2017/176749**
Bid Deadline : 17.05.2017
Approx. Cost : 29.067.797,86 TL
Winner : **TOSÇELİK A.Ş.**
Contract cost : 20.264.085,29 TL
- **BOTAS GENERAL DIRECT. : 3. İtem of steel pipes and fittings for Elazığ drinking water main lines**
Bid Method : Open
Tender Reg.No : **2017/307368**
Bid Deadline : 25.07.2017
Approx. Cost : 104.363.951,22 TL
Tender canceled.
The contestants:
- **EMEK+NOKSEL-ERCİYAS İ.O.**
- **TOSÇELİK BORU**
- **BORUSAN MANNESMAN**
- **ÜMRAN BORU** (THANKİNG)
- **BOTAS GENERAL DIRECT. : 3. İtem of steel pipes and fittings for Elazığ drinking water main lines**
Bid Method : Open
Tender Reg.No : **2017/380137**
Bid Deadline : 06.09.2017
Approx. Cost : 98.661.575,44 TL
Tender was held second time and evaluation has been completed.
Bidders and offers:

FIRMS	OFFERS (TL)
• TOSÇELİK BORU	83.474.109,37
• EMEK+NOKSEL-ERCİYAS İ.O.	84.437.664,67
• ÜMRAN BORU	THANKİNG

- **BOTAS GENERAL DIRECT. : Steel pipes for Şırnak Branching DGBH**
Tender Reg.No : **2017/296178**
Bid Deadline : 18.07.2017
3 firms have submitted offers. Results are expected to be announced.
Bidders and offers:

FİRMALAR	OFFERS (TL)
• TOSYALI/TOSÇELİK A.Ş.	3.628.688,00
• ÜMRAN BORU	3.954.415,00
• BORUSAN	4.181.479,00
• ÇAYIROVA BORU	THANKİNG

- **BOTAS GENERAL DIRECT. : Steel pipes for Şırnak Branching DGBH**
Tender Reg.No : **2017/309644**
Bid Deadline : 20.07.2017
Approx. Cost : 1.135.335,00 TL
The only bidder is **TOSYALI/TOSÇELİK A.Ş.** quoting 956.042,06 TL. Final results have not been announced.
- **İSTANBUL-İSKİ GENERAL DIRECT. : 8 İtems of 163.000 m. dutcile font pipes.**
Tender Reg.No : **2017/12422**
Bid Deadline : 22.02.2017
Approx. Cost : 18.036.162,50 TL
SAMSUN MAKİNE SANAYİ and EMEK BORU A.Ş. attended the bidding but the tender has been canceled
- **DARICA MUNICIPALITY (KOCAELİ) 2 ea buses and 1 ea patient transp. ambulances.**
Bid Method : Open
Tender Reg.No : **2017/64935**
Bid Deadline : 08.03.2017
Patient transp. ambulances
Approx. Cost : 136.438,34 TL
Winner : **AMBULANS A.Ş.**
Contract cost : 128.750,00 TL
- **İZMİR ULAŞIM HİZMETLERİ VE MAKİNE SAN A.Ş: 11 İtem bus spare parts**
Bid method : 4734/3-g
Tender Reg.No : **2017/43728**
Bid Deadline : 01.02.2017
Winner : **SÜTRAK KLİMA A.Ş**
Approx. Cost : 375.836,63 TL
Contract cost : 104.490,00 TL
- **GAZİANTEP WATER & SEWERAGE ADMIN. (GASKİ):**
Repair and maintenance vehicle
Bid method : Open
Tender Reg.No : **2016/553642**
Bid Deadline : 17.01.2017
Winner : **BAKSAN MAKİNE**
Approx. Cost : 382.500,00 TL
Contract cost : 343.300,00 TL
- **İSTANBUL METROPOLITAN MUNICIPALITY; 50 set (4 -vehicles) 200 ea subway vehicles**
Bid method : Open
Tender Reg.No : **2017/55628**
Bid Deadline : 25.04.2017
The tender has been canceled as the emergency subway vehicle requirements need reviewing.
- **İSTANBUL METROPOLITAN MUNICIPALITY; 50 sets (4 -vehicles) 200 ea subway vehicles; Dudullu-Bostancı and Mahmutbey-Esenyurt subway lines rail transport system 120 ea subway vehicles and commissioning.**
Tender Reg.No : **2017/229012**
Bid Deadline : 18.08.2017
The technical evaluation has been completed and no results have been announced.
The contesting firms:

FIRMS	OFFERS (TL)
• HYUNDAI ROTEM (S.Korea)	564.000.000
• CRRCMNG (China/TR)	565.000.000

- **KAYSERİ- KASKİ GENERAL DIRECT. : Gr.1. 89 İtem Ductile pipes**
Tender Reg.No : **2016/553642**
Bid Deadline : 17.01.2017
Winner : **SAMSUN MAKİNE SANAYİ A.Ş.**
Approx. Cost : 7.874.186,25 TL
Contract cost : 11.165.500,00 TL
- **ANKARA METROPOLITAN MUNICIPALITY; Snow blades and salt spreader equipment.**
Tender Reg.No : **2016/586970**
Bid Deadline : 27.01.2017
Winner : **SED MÜHENDİSLİK**
Approx. Cost : 1.510.000,00 TL
Contract cost : 1.234.980,00 TL

- **ANKARA METROPOLITAN MUNICIPALITY: 1 İtem**
Snow blades.
Tender Reg.No : **2016/561505**
Bid Deadline : 30.01.2017
Winner : **Şİ-MAK POMPA**
Approx. Cost : 142.000,00 TL
Contract cost : 119.200,00 TL

- **NATIONAL DEFENSE MINISTRY (MSB) - İSTANBUL**
TEDARİK BÖLGE BAŞKANLIĞI: Various construction
machines.
Bid Method : Open
Tender Reg.No : **2016/246294**
Bid Deadline : 30.11.2016
Approx. Cost : 7.667.000,00 TL
Below are the winners:

 - **2 ea offroad telescopic cranes**
Winner : **İNDEKS ELEKTRİK A.Ş**
Approx. Cost : 3.400.000,00 TL
Contract cost : 3.296.500,00 TL
 - **Trailers**
Winner : **İNDEKS ELEKTRİK A.Ş**
Approx. Cost : 725.000,00 TL
Contract cost : 461.250,00 TL
 - **6 ea diesel forklifts**
Winner : **İNDEKS ELEKTRİK A.Ş**
Approx. Cost : 516.000,00 TL
Contract cost : 433.500,00 TL
 - **Battery powered forklift**
Winner : **FATİH EFE MAK.**
Approx. Cost : 826.000,00 TL
Contract cost : 769.300,00 TL

- **ALAPLI MUNICIPALITY (ZONGULDAK): Fire fighting**
equipment on chassis truck
Tender Reg.No : **2017/47231**
Bid Deadline : 07.02.2017
Winner : **BELTAŞ YANGIN LTD.**
Approx. Cost : 193.333,33 TL
Contract cost : 170.000,00 TL
- **ORDU WATER AND SEWERAGE ADMIN. (OSKİ): 3753**
metre 800 mm diam. spiral welded steel pipes
Tender Reg.No : **2017/49940**
Bid Deadline : 07.03.2017
Winner : **EMEK BORU A.Ş.**
Approx. Cost : 2.326.221,69 TL
Contract cost : 1.784.176,20 TL
- **BALIKESİR METROPOLITAN MUNICIPALITY: 6 İtem**
equipment and bodybuilding equip. to be mounted on
vehicle
Tender Reg.No : **2017/104341**
Bid Deadline : 03.04.2017
Winner : **KOLUMAN A.Ş.**
Approx. Cost : 975.000,00 TL
Contract cost : 925.000,00 TL
- **DİYARBAKIR METROPOLITAN MUNICIPALITY: By**
means of DMO 10 ea buses
Tender Reg.No : **2017/102395**
Bid Deadline : 03.04.2017
Winner : **BMC A.Ş.**
Approx. Cost : 6.750.000,00 TL
Contract cost : 5.880.000,00 TL
- **ŞAHİNBEY MUNICIPALITY (G.ANTEP) By means of**
DMO , 10 ea 12 M3 cap. 8 Mm Hardox made dump, with
3 Mt snow blade, 7 M3 salt spreading cap. snow truck on
Ford Cargo 2533 6x2 chassis.
Tender Reg.No : **2017/83813**
Winner : **OTOKOÇ A.Ş.**
Approx. Cost : 2.810.000,00 TL
Contract cost : 2.776.500,00 TL
- **DSİ 18. BÖLGE MÜDÜRLÜĞÜ (ISPARTA) Steeel pipes**
and HDPE pipes.
- **Required for Afyonkarahisar Çobanlar Seyitler irrigation**
facilities. (1. item) 4932 metre steel pipes (1500 mm diam.
10 Atm)
Tender Reg.No : **2016/ 612858**
Bid Deadline : 16.03.2017
Winner : **NOKSEL A.Ş.**
Approx. Cost : 19.885.500,43 TL
App.Cost under Contr. : 7.767.900,00 TL
Contract cost : 4.494.531,60 TL
- **Required for Afyonkarahisar Çobanlar Seyitler irrigation**
facilities. (1.item) 53112 metre HDPE pipes
Tender Reg.No : **2016/ 612858**
Bid Deadline : 16.03.2017
Winner : **ESEN PLASTİK SAN.**
Approx. Cost : 19.885.500,43 TL
App.Cost under Contr : 12.117.600,43 TL
Contract cost : 10.652.217,84 TL
- **Required for Afyonkarahisar Çay Selevir irrigation facilities**
(1 item) 23.280 metre steel pipes.
Tender Reg.No : **2016/612816**
Bid Deadline : 15.03.2017
Winner : **EMEK BORU A.Ş.**
Approx. Cost : 44.999.852,73 TL
App.Cost under Contr : 35.737.948,54 TL
Contract cost : 33.621.876,00 TL
- **DSİ 4. BÖLGE MÜDÜRLÜĞÜ (KONYA) : Required for**
Ereğli-İvriz Sulaması irrigation facilities (1.item) 21.623,00
metre HDPE pipes and 16.506,00 metre steel pipes
Tender Reg.No : **2017/86266**
Bid Deadline : 30.03.2017
16.596.00 metre steel pipes
Approx. Cost : 17.000.136,50 TL
Winner : **NOKSEL+EMEK BORU İ.O.**
Contract cost : 12.836.724,00 TL
21.623,00 metre HDPE pipes
Approx. Cost : 3.804.899,62 TL
Winner : **YILBOR A.Ş.**
Contract cost : 3.563.422,91 TL
- **İSTANBUL METROPOLITAN MUNICIPALITY:The first**
notice for 103 ea solo, 97 ea articulated total 200 ea
electric buses was made under file no 2017/32564 but it
was later canceled.. A second tender notice was made on
13 Apr. 2017 under file no 2017/173376 with deadline
being 17 May 2017 when the only bidder was
BOZANKAYA OTOMOTİV+TCV over a total estimated
cost of 783.125.825,00 TL. Its quotation was
645.070.000,00 TL. But the tender was canceled once
more on the grounds that technical specs needed revision
and only one bidder appeared.

- **GAZİANTEP WATER & SEWERAGE ADMIN. (GASKİ):**
Fueloil vehicle
 Bid method : Auction
 Tender Reg.No : **2017/265**
 Bid Deadline : 12.01.2017
 Winner : **BAKSAN YÜRÜYEN MERDİVEN**
 Approx. Cost : 168.000,00 TL
 Contract cost : 158.000,00 TL

- **KAHRAMANMARAS METROPOLITAN MUNICIPALITY:**1 ea fire fighting vepicle with 55 m.ladder
 Bid method : Open
 Tender Reg.No : **2017/108122**
 Bid Deadline : 17.04.2017
 Winner : **VOLKAN İTFAİYE A.Ş.**
 Approx. Cost : 3.478.000,00 TL
 Contract cost : 3.295.500,00 TL

- **KOCAELİ METROPOLITAN MUNICIPALITY:** 20 ea diesel low bed 5,5-6.6 mt. buses.
 Bid method : Open
 Tender Reg.No : **2017/114380**
 Bid Deadline : 19.04.2017
 Winner : **KARSAN A.Ş.**
 Approx. Cost : 3.900.000,00 TL
 Contract cost : 3.560.000,00 TL

- **ELAZİĞ MUNICIPALITY (EBUAŞ) :** For 15 ea 16-20 metre electric buses (ELBÜS); charging, central traffic monitoring, revisions maintenance, personel training, operational management, and vehicle parking, ELBÜS Admin.build.and depot.workshop constr..
 Bid method : Open
 Tender Reg.No : **2017/111661**
 Bid Deadline : 24.04.2017
 Winner : **BOZANKAYA OTO. MAK. İML.**
 Approx. Cost : 53.985.104,84 TL
 Contract cost : 51.154.752,00 TL

- **BOTAŞ GENERAL DIRECT. :** Required for Marmara Ereğlisi LNG Terminal-Önerler N.Gas Loop Lines, Steel pipes with 24inch 609,6mm X65 7,1mm in w.thickness 10,695 metre 24inch 609,6mm X65 8,7mm w.thickness 636 metre 24inch 609,6mm X65 10,3mm w.thickness 4.526 metre 24inch 609,6mm X60 14,3mm w.thickness 90 metre
 Bid method : Open
 Tender Reg.No : **2017/139101**
 Bid Deadline : 26.04.2017
 Winner : **NOKSEL BORU A.Ş.**
 Approx. Cost : 9.245.993,85TL
 Contract cost : 5.485.892,00 TL

- **ŞANLIURFA METROPOLITAN MUNICIPALITY:** 10 ea trolleybuses.
 Bid method : Open
 Tender Reg.No : **2017/105846**
 Bid Deadline : 24.04.2017
 Winner : **BOZANKAYA OTO. MAK. İML.**
 Approx. Cost : 72.505.287,42 TL
 Contract cost : 69.974.640,00 TL

- **MANİSA METROPOLITAN MUNICIPALITY:** 5 ea funeral vehicles
 Bid method : Open
 Tender Reg.No : **2017/82490**
 Bid Deadline : 24.03.2017
 Winner : **ERCİYES HİZ. ARAÇL. LTD**
 Approx. Cost : 535.000,00 TL
 Contract cost : 506.500,00 TL

- **KONYA METROPOLITAN MUNICIPALITY:** 20 ea 12 metre solo buses (high step, disabled ramp, more passenger cap).
 Bid method : Open
 Tender Reg.No : **2017/135098**
 Bid Deadline : 03.05.2017
 Winner : **OTOKAR A.Ş.**
 Approx. Cost : 13.450.000,00 TL
 Contract cost : 11.400.000,00 TL

- **STATE HIGHWAYS GEN. DIRECT. :**4 ea asphalt distributors mounted on truck.
 Bid method : Open
 Tender Reg.No : **2017/132926**
 Bid Deadline : 28.04.2017
 Winner : **OTOKOÇ A.Ş.**
 Approx. Cost : 2.040.000,00 TL
 Contract cost : 1.660.000,00 TL

- **STATE HIGHWAYS GEN. DIRECT. :** 4 ea asphalt distributors mounted on truck. 25 ea dump trucks, 25 ea salt spreaders, 25 ea snow blades, 5 ea rotatory snow spraying equipment, 5 ea road parapets and notice boards.
 Tender Reg.No : **2017/280444**
 Bid Deadline : 13.07.2017
 Winner : **KOLUMAN A.Ş.**
 Approx. Cost : 26.525.170,00 TL
 Contract cost : 26.250.400,00 TL

- **STATE HIGHWAYS GEN. DIRECT. :** 1.item: 17 ea vibratory combined rollers; 2.item: 8 ea wheeled rollers .
 Bid method : Open
 Tender Reg.No : **2017/147941**
 Bid Deadline : 05.05.2017
 Winner : **WIRTGEN ANKARA MAK. SAN. A.Ş./HAMM**
 Approx. Cost : 4.253.115,00 TL
 1. item:Contr. Based App.
 Cost :2.424.544,00 TL
 Contract cost : 1.241.000,00 TL
 Winner : **TSM GLOBAL TURKEY MAKİNA**
 Approx. Cost : 4.253.115,00 TL
 2. item: Contr. Based App.
 Cost : 2.424.544,00 TL
 Contract cost : 1.856.000,00TL

- **KONYA METROPOLITAN MUNICIPALITY:** 1 ea 8x4 Trucks
 Tender Reg.No : **2017/84315**
 Bid Deadline : 24.03.2017
 Winner : **OTOKOÇ A.Ş**
 Approx. Cost : 356.730,00 TL
 Contract cost : 335.000,00 TL

- **BURSA-BUSKİ GENERAL DIRECT. : 8 İtem steel bellmouth pipes**
Tender Reg.No : **2017/148625**
Bid Deadline : 11.05.2017
Approx. Costs:
1.item : 26.845.459,15 TL
Winner : **ÜMRAN+EMEK BORU**
Contract cost : 21.280.000,00 TL
2.item : 24.065.133,21 TL
Winner : **ERCİYAS+NOKSEL BORU**
Contract cost : 15.670.650,00 TL
- **ÇİZRE MUNICIPALITY (ŞIRNAK): 25 –passenger cap. 4 ea buses.**
Bid method : Open
Tender Reg.No : **2017/227974**
Bid Deadline : 02.06.2017
Winner : **UNAT OTOMOTİV LTD**
Approx. Cost : 986.666,67 TL
Contract cost : 892.000,00 TL
- **DSİ GENERAL DIRECT. : Elazığ drinking water main lines (11,8 km.part) 2 item steel pipes and fittings**
Bid method : Open
Tender Reg.No : **2017/176749**
Bid Deadline : 17.05.2017
Winner : **TOSÇELİK A.Ş.**
Approx. Cost : 29.067.797,86 TL
Contract cost : 20.264.085,29 TL
- **KAYSERİ METROPOLİTAN MUNICIPALITY: 2 İtems fire fighting vehicles.**
Bid method : Open
Tender Reg.No : **2017/97099**
Bid Deadline : 06.04.2017
Orders placed as follows:
• **2 ea 6 Ton water cap., fire fighting vehicles with 28 Metre ladder**
Winner : **VOLKAN İTFAİYE A.Ş**
Approx. Cost : 1.550.000,00 TL
Contract cost : 1.438.000,00 TL
- **2 ea 6 Ton water cap., fire fighting and water supply vehicles**
Winner : **KATMERCİLER A.Ş.**
Approx. Cost : 950.000,00 TL
Contract cost : 875.980,00 TL
- **MSB İSTANBUL TEDARİK BÖLGE BAŞKANLIĞI: 3 ea dump trucks (6x4)**
Tender Reg.No : **2017/173129**
Bid Deadline : 15.05.2017
Winner : **OTOKOÇ A.Ş.**
Approx. Cost : 1.050.000,00 TL
Contract cost : 963.000,00 TL
- **DHMİ GENERAL DIRECT. : 29 ea emergency fire fighting vehicles**
Tender Reg.No : **2017/118451**
Bid Deadline : 25.05.2017
Winner : **VOLKAN İTFAİYE A.Ş.**
Approx. Cost : 11.740.650,00 TL
Contract cost : 9.367.000,00 TL
- **DSİ 15. BÖLGE MÜDÜRLÜĞÜ (SANLIURFA):in various diameters; 32 152 m CTP pipes and fittings, 121 520 m PE100 (HDPE) pipes and fittings, 12 216 m steel pipes and fittings**
Bid method : Open
Tender Reg.No : **2017/182518**
Bid Deadline : 23.05.2017
32 152 m CTP Pipes and fittings.
Approx. Cost :39.002.047,77 TL
Winner : **SÜPERLİT BORU**
Contract cost : 40.231.026,00 TL
121 520 m PE100 (HDPE) Pipes and fittings
Approx. Cost :13.087.328,89 TL
Winner : **NETBOR PLASTİK**
Contract cost : 10.976.561,33 TL
12 216 m Steel Pipes and fittings
Approx. Cost 26.017.718,88 TL
Winner : **TEKİN DEMİR**
Contract cost : 23.365.947,84 TL
- **DHMİ GENEL GENERAL DIRECT. :15 ea snow spraying (rotatory) vehicles.**
Tender Reg.No : **2017/149503**
Bid Deadline : 31.05.2017
Winner : **FRESİA (İtaly)**
Approx. Cost : 17.477.766 TL
Contract cost : 15.585.000,00
- **KAHRAMANMARAS MUNICIPALITY: Fire fighting vehicle with 55 metre ladder, panelvan car, double cabin truck,**
Tender Reg.No : **2017/108122**
Bid Deadline : 17.04.2017
Winner : **VOLKAN İTFAİYE. A.Ş.**
Approx. Cost : 3.712.295,00 TL
Sözleşme Esas YM: 3.478.000,00
Contract cost : 3.295.500,00 TL
- **STATE HIGHWAYS GEN. DIRECT (KGM) . : 4 ea Rotatory –snow spraying vehicles self propelled.**
Tender Reg.No : **2017/132629**
Bid Deadline : 26.04.2017
Winner : **KOLUMAN A.Ş.**
Approx. Cost : 4.424.000,00 TL
Contract cost : 1.131.945,00 TL/adet
- **STATE HIGHWAYS GEN. DIRECT (KGM) . : 8 ea fuelou tankers mounted on truck .**
Tender Reg.No : **2017/205998**
Bid Deadline : 05.06.2017
Winner : **OTOKOÇ A.Ş.**
Approx. Cost : 3.132.440,00 TL
Contract cost : 2.089.200,00 TL
- **STATE HIGHWAYS GEN. DIRECT (KGM) . : Semi trailers for state roads (Low- bed), For tracting of Semi trailer cased trailers and Relaytank 8 ea 4x2 towing vehicles.**
Tender Reg.No : **2017/234077**
Bid Deadline : 22.05.2017
Winner : **OTOKOÇ A.Ş.**
Approx. Cost : 3.186.136,00 TL
Contract cost : 2.312.000,00 TL

- **STATE HIGHWAYS GEN. DIRECT (KGM) . :5 ea self propelled road sweepers.**
Tender Reg.No : **2017/148085**
Bid Deadline : 09.05.2017
Winner : **TEKMAR TEKNİK MARKET**
Approx. Cost : 2.492.000,00 TL
Contract cost : 1.972.000,00 TL
- **KOCAELİ METROPOLİTAN MUNICIPALITY: 1 ea Cataner Line Maintenance Vehicle**
Tender Reg.No : **2017/257558**
Bid Deadline : 23.06.2017
Winner : **KARSU VİNÇ LTD.**
Approx. Cost : 907.809,33 TL
Contract cost : 815.840,00 TL
- **İSTANBUL ASFALT FABRİKALARI A.Ş: 12 ea 4*4 snow shovelling and salt spreading vehicles .**
Bid method : 4734/3-g
Tender Reg.No : **2017/227637**
Bid Deadline : 16.05.2017
Winner : **ARMAKSA A.Ş.**
Approx. Cost : 8.832.000,00 TL
Contract cost : 8.280.000,00 TL
- **DSİ 6. BÖLGE MÜDÜRLÜĞÜ (ADANA): For Mersin Anamur Alaköprü irrigation, pipes and fittings özel 2.unit (2128,4 mt)**
Bid method : Open
Tender Reg.No : **2017/199326**
Bid Deadline : 07.06.2017
Winner : **ERCİYAS ÇELİK BORU A.Ş.**
Approx. Cost : 6.061.085,18 TL
Contract cost : 4.352.578,000 TL
- **DSİ 6. BÖLGE MÜDÜRLÜĞÜ (ADANA): For Mersin Anamur Alaköprü irrigation, pipes and fittings 2.unit (2128,4 mt)**
Tender Reg.No : **2017/199326**
Bid Deadline : 07.06.2017
Winner : **ERCİYAS ÇELİK BORU A.Ş.**
Approx. Cost : 6.061.085,18 TL
Contract cost : 4.352.578,000 TL
- **ÇORUM MUNICIPALITY:5 ea 6x2 dump trucks.**
Bid method : Open
Tender Reg.No : **2017/170116**
Bid Deadline : 08.05.2017
Winner : **KATMERCİLER A.Ş.**
Approx. Cost : 1.450.000,00 TL
Contract cost : 1.323.550,00 TL
- **HEALTH MINISTRY'S ACİL SAĞLIK HİZ. GEN. MÜD. :218 ea ambulances.**
Bid method : Open
Tender Reg.No : **2017/269358**
Bid Deadline : 10.07.2017
Evaluations completed. Results have not been disclosed.
Approx. Costs:
For -4x2 191.052,95 TL/ea. The bidding firm ; **OTOKOÇ A.Ş..**
For -4x4 207.500,00 TL/ea
The bidding firm was **TAN OTO** offering 219.420,00 TL/ea for 4x4 .But tender was canceled.
- **ONİKİŞUBAT MUNICIPALITY (K.MARAS) Asphalt finishers , wheeled excavators**
Tender Reg.No : **2017/184025**
Bid Deadline : 11.05.2017
Winner : **ASCENDUM MAK. AŞ**
Approx. Cost : 834.500,00 TL
Contract cost : 815.000,00 TL
- **DENİZLİ MUNICIPALITY: 1 ea snow blower truck (Rotatory). Asphalt finisher, wheeled excavators**
Tender Reg.No : **2017/294034**
Bid Deadline : 07.07.2017
Winner : **UĞUREL DIŞ TIC.LTD. ŞTİ.**
Approx. Cost : 1.490.000,00 TL
Contract cost : 1.480.000,00 TL
- **İSU GENERAL DIRECT. (KOCAELİ): 5.972.976,00 kg ductile pipes, 422.536,30 kg fittings**
Tender Reg.No : **2017/188323**
Bid Deadline : 23.05.2017
Winner : **SAMSUN MAKİNE SAN.**
Approx. Cost : 30.579.471,10 TL
Contract cost : 26.108.359,27 TL
- **MERSİN WATER AND SEWERAGE ADMIN.. (MESKİ)10 ea crew vehicles for drinkingwater lines maintenance**
Tender Reg.No : **2017/238369**
Bid Deadline : 20.06.2017
Winner : **PARAGON MAK. A.Ş.**
Approx. Cost : 4.655.137,50 TL
Contract cost : 4.329.000,00 TL
- **TURKISH COAL WORKS (TKİ):5 ea 6x2 minimum 280 BG motor cap. ADR' fueloil tankers**
Tender Reg.No : **2017/219378**
Bid Deadline : 03.08.2017
Winner : **TAN OTO LTD.**
Approx. Cost : 2.150.000,00 TL
Contract cost : 1.686.250,00 TL
- **KOCAELİ METROPOLİTAN MUNICIPALITY:5 ea fire fighting water sprinklers, 4 ea fire fighting vehicles with ladder.**
Tender Reg.No : **2017/239140**
Bid Deadline : 23.06.2017
Approx. Costs:
4 ea 7 ton vehicles: 2.020.000 TL
1 ea 6x6 vehicles: 502.666,67 TL
4 ea vehicles with 42 m. ladder :11.905.333,33 TL
Order awards:
ZİMAG ARAÇ VE MAKİNASAN.VE TIC.A.Ş.
2 Ton cap. fire fighting vehicles:
Approx. Cost :502.666,67 TL
Contract value :500.000,00 TL
ANKARA ÇELİK YANGINGÜVENLİK SİST. SAN. VETİC.A. Ş.
42m fire fighting water, articulated vehicle with ladder
Approx. Cost :11.905.333,33 TL
Contract value : 11.500.000,00 TL
VOLKAN İTFAİYE ARAÇLARI SANAYİ VE TİCARET ANONİM ŞİRKETİ
7 Ton Cap. fire fighting water sprinkler
Approx. Cost : 2.020.000,00 TL
Contract value : 1.978.800,00 TL

- **MERSİN METROPOLITAN MUNICIPALITY: 100 ea 3 ton fighting water tankers.**
 Bid method : Open
 Tender Reg.No : **2017/73893**
 Bid Deadline : 23.03.2017
 Winner : **PIŞIRGEN MAKİNE LTD.**
 Approx. Cost : 1.012.333,33 TL
 Contract cost : 908.000,00 TL
- **GAZİANTEP METROPOLITAN MUNICIPALITY: 2 ea fueloil tankers.**
 Bid method : Open
 Tender Reg.No : **2017/252685**
 Bid Deadline : 29.06.2017
 Winner : **TRACO HAMLE A.Ş.**
 Approx. Cost : 470.330,00 TL
 Contract cost : 420.000,00 TL
- **HEALTH MINISTRY'S ACİL SAĞLIK HİZ. GENERAL DIRECT. :220 ea diesel panelvan ambulances**
 Bid method : Open
 Tender Reg.No : **2017/165397**
 Bid Deadline : 15.07.2017
 The tender was canceled.
 The bidding firms: **OTOKOÇ A.Ş., TAN OTO and PLATFORM A.Ş.**
- **DSİ. - MAKİNE İMALAT VE DONATIM DAİRESİ BAŞKANLIĞI: 48 ea fueloil tankers.**
 Bid method : Open
 Tender Reg.No : **2017/293434**
 Bid Deadline : 20.07.2017
 Winner : **KATMERCİLER A.Ş.**
 Approx. Cost : 23.000.304,48 TL
 Contract cost : 12.579.840,00 TL
- **DENİZLİ METROPOLITAN MUNICIPALITY: 3 ea ceremony type funeral vehicles:4 ea funeral washing vehicles on 4x2 chassis:6 ea**
 Bid method : Open
 Tender Reg.No : **2017/227064**
 Bid Deadline : 09.06.2017
 Winner : **EKİP ARAÇ ÜSTÜ EKİPMAN**
 Approx. Cost : 2.304.320,00 TL
 Contract cost : 2.081.000,00 TL
- **SAMSUN METROPOLITAN MUNICIPALITY: By means of DMO, 19 ea Buses: BMC Neocity 10 metre diesel (E6 Motor, low bed, disabled compatible, autom. transmiss., digital line indicator, 26 seats+62 standing+1 driver cap.) red-white municipal type.**
 Bid method : 4734/3-g
 Tender Reg.No : **2017/359739**
 Bid Deadline : 03.07.2017
 Winner : **BMC A.Ş.**
 Contract cost : 6.650.000,00 TL
- **ANKARA METROPOLITAN MUNICIPALITY: 17 ea fire fighting vehicles**
 Tender Reg.No : **2017/333652**
 Bid Deadline : 12.09.2017
 The only bidder **ZİMAG ARAÇ MAKİNA SAN A.Ş.** The tender was canceled
- **KONYA METROPOLITAN MUNICIPALITY: 10 ea fire fighting vehicles with portable ladder**
 Tender Reg.No : **2017/341659**
 Bid Deadline : 16.08.2017
 Approx. Cost : 2.228.333,TL
 The contesting firms;
 • **CNR LTD.ŞTİ (ÇINAR İTFAİYE)**
 • **DAĞ BELEDİYE EKİPMANLARI**
 • **BAKSAN LTD**
 • **GİMKAT**
 • **EKİP ARAÇ ÜSTÜ EKİPMAN**
- **GAZİANTEP METROPOLITAN MUNICIPALITY;For public transports, Euro VI compatible 50 CNG Buses**
 Bid method : Closed session
 Bid Deadline : 29.08.2017
 Price envelopes opened on 30 Oct. 2017. 5 firms submitted offers and best from BMC. Evaluations underway. Results will be finalized after approval of the financing institution. The contesting firms: **(DETAY-1541) FİRMALAR**
 • **BMC A.Ş.**

Unit price	142.912,68 Euro
Total	7.145.634 Euro
- **MERCEDES BENZ TÜRK A.Ş.**

Unit price	179.261,5 Euro
Total	8.963.075 Euro
- **TEMSA A.Ş.**

Unit price	194.591,28 Euro
Total	9.729.564 Euro
- **KARSAN A.Ş.**

Unit price	199.433 Euro
Total	9.971.650 Euro
- **MAN A.Ş.**

Unit price	264.995,23 Euro
Total	13.249.761,86 Euro
- **DSİ 5. BÖLGE MÜDÜRLÜĞÜ (ANKARA): Bolu-Seben Taşlıyayla pond irrigation facilities**
 Tender Reg.No : **2017/381397**
 Bid Deadline : 12.09.2017
 Approx. Cost : 32.803.639,36 TL
 Evaluations underway..
 The contesting firms;
 • **ERCİYAS+EMEK BORU İ.O**
 • **NOKSEL BORU**
 • **ÜMRAN BORU**
- **DMO DİYARBAKIR İRTİBAT BÜROSU: Grader.**
 Tender reg.no : **2017/24586**
 Bid deadline : 15.01.2018
 Winner : **BORUSAN MAKİNE A.Ş.**
 Contract cost : 948.150,00 TL
- **DMO ESKİŞEHİR BÖLGE MÜDÜRLÜĞÜ Grader.**
 Tender reg.no : **2017/639926**
 Bid deadline : 05.12.2017
 Winner : **BORUSAN MAKİNE A.Ş.**
 Contract cost : 985.550,00 TL

- **STATE HIGHWAYS:** 40 ea dump trucks, 40 ea salt spreaders, 40 ea front snow plough blades and 40 ea side snow plough blades
Tender reg. no : 2017/258566
Bid deadline : 03.07.2017
Winner : ODABAŞI OTOMOTİV A.Ş.
Approx. Cost : 22.291.680,00 TL
Contract cost : 19.659.000,00TL

Firms Receiving DMO's Bus Orders

- **STATE SUPPLY OFFICE- DMO I NOLU SATINALMA DAİRE BAŞKANLIĞI:**15 ea BMC new generation diesel buses
Tender Reg.No : 2017/517864
Bid Deadline : 11.10.2017
Winner : BMC SAN VE TİC A.Ş
Approx. Cost : 8.125.500,00 TL
Contract cost : 6.000.000,00 TL
- **DMO I NOLU SAT. D.BSK:**15 ea BMC Procity buses
Tender Reg.No : 2017/521120
Bid Deadline : 11.10.2017
Winner : BMC SAN AŞ
Approx. Cost : 8.125.500,00 TL
Contract cost : 6.000.000,00 TL
- **DMO I NOLU SAT. D.BSK:** 15 ea BMC Procity (For Antalya M.Municipality)
Tender Reg.No : 2017/574020
Bid Deadline : 18.10.2017
Winner : BMC TİCARET A.Ş
Approx. Cost : 8.125.500,00 TL
Contract cost : 6.000.000,00 TL
- **DMO I NOLU SAT. D.BSK:** 22 ea BMC Buses (For Antalya M.Municipality)
Tender Reg.No : 2017/573690
Bid Deadline : 18.10.2017
Winner : BMC TİCARET A.Ş
Approx. Cost : 8.771.400,00 TL
Contract cost : 5.586.000,00 TL
- **DMO I NOLU SAT. D.BSK:**15 ea BMC Neocity 8.5 m. diesel (E6 Motor, low bed, municipal)
Tender Reg.No : 2017/315304
Bid Deadline : 16.06.2017
Winner : BMC OTOMOTİV A.Ş.
Approx. Cost : 5.921.280,00 TL
Contract cost : 4.410.000,00TL
- **DMO I NOLU SAT. D.BSK:**22 ea BMC Neocity 8.5 m. diesel (Euro6 Motor, low bed, municipal bus)
Tender Reg.No : 2017/321756
Bid Deadline : 30.05.2017
Winner : BMC OTOMOTİV A.Ş.
Approx. Cost : 8.684.544,00 TL
Contract cost : 6.468.000,00 TL
Contract Date : 23.06.2017
- **DMO I NOLU SATINALMA D.BSK:**14 ea BMC Buses
Tender Reg.No : 2017/319906

Bid Deadline : 31.05.2017
Winner : BMC SAN. TİC. A.Ş.
Approx. Cost : 7.508.718,00 TL
Contract cost : 5.600.000,00 TL

- **DMO I NOLU SAT. D.BSK:**15 Ea BMC Buses.
Tender Reg.No : 2017/505484
Bid Deadline : 29.09.2017
Winner : BMC SANAYİ VE TİC. A.Ş.
Approx. Cost : 8.125.500,00 TL
Contract cost : 6.000.000,00 TL

- **DMO I NOLU SAT. D.BSK:**14 Ea BMC Brand Buses
Tender Reg.No : 2017/319906
Bid Deadline : 31.05.2017
Winner : BMC SAN. TİC. A.Ş.
Approx. Cost : 7.508.718,00 TL
Contract cost : 5.600.000,00 TL

- **DMO I NOLU SAT. D.BSK:** 10 ea vehicles (12 mt diesel, For Kırşehir Municipality)
Tender Reg.No : 2017/469770
Bid Deadline : 14.09.2017
Winner : BMC A.Ş.
Approx. Cost : 5.363.370,00 TL
Contract cost : 4.000.000,00 TL

- **DMO I NOLU SAT. D.BSK:** 18 ea vehicles (8.5 mt diesel, For Kırşehir Municipality)
Tender Reg.No : 2017/463134
Bid Deadline : 14.09.2017
Winner : BMC A.Ş.
Approx. Cost : 7.105.536,00 TL
Contract cost : 5.292.000,00 TL

- **DMO I NOLU SATINALMA D.BSK:** 10 ea BMC Buses
Tender Reg.No : 2017/593521
Bid Deadline : 27.10.2017
Winner : BMC SANAYİ A.Ş
Approx. Cost : 7.809.200,00 TL
Contract cost : 4.000.000,00 TL
Delivery period : 27.11.2017 - 27.03.2018

- **DMO I NOLU SATINALMA D.BSK:**6 Ea BMC Neocity Buses, 8.5 m. diesel
Tender Reg.No : 2017/606215
Bid Deadline : 20.11.2017
Winner : BMC OTOMOTİV A.Ş
Approx. Cost : 2.368.512,00 TL
Contract cost : 1.818.000,00 TL

- **DMO I NOLU SAT. D.BSK:** 5 ea BMC Procity Buses.
Tender Reg.No : 2017/706585
Bid Deadline : 27.12.2017
Winner : BMC SAN. TİC. A.Ş.
Approx. Cost : 2.183.040,00 TL
Contract cost : 2.055.000,00 TL

- **DMO I NOLU SATINALMA D.BSK:** 1 ea OTOKAR Buses
Tender Reg.No : 2017/188773
Bid Deadline : 09.03.2017
Winner : OTOKAR A.Ş.
Approx. Cost : 453.100,00 TL
Contract cost : 460.000,00 TL

- **DMO I NOLU SATINALMA D.BSK: 25 ea Otokar Sultan Maxi (31+1+1 passenger cap.) Buses**
Tender Reg.No : **2017/507362**
Bid Deadline : 02.10.2017
Winner : **OTOKAR OTOMOTİV A.Ş**
Approx. Cost : 6.100.000,00 TL
Contract cost : 5.450.000,00 TL
- **DMO I NOLU SATINALMA D.BSK: 1 ea Temsa bus**
Tender Reg.No : **2016/587910**
Bid Deadline : 21.12.2016
Winner : **AZİZOĞLU MOT. ARAÇLAR**
Approx. Cost : 146.480,00 TL
Teklifi : 146.200,00 TL
- **DMO I NOLU SATINALMA D.BSK;2 ea bus**
Tender Reg.No : **2017/614069**
Bid Deadline : 21.11.2017
Winner : **AZİZOĞLU MOT. ARAÇLAR**
Approx. Cost : 1.087.008,00 TL
Contract cost : 1.027.000,00 TL
- **DMO I NOLU SATINALMA D.BSK;1 ea Temsa Buses**
Tender Reg.No : **2017/531547**
Bid Deadline : 13.10.2017
Winner : **AZİZOĞLU MOT. ARAÇLAR**
Approx. Cost : 400.000,00 TL
Contract cost : 378.500,00 TL
- **DMO I NOLU SATINALMA D.BSK; 21 ea 2017 Model Temsa Brand Buses (For Mersin M.Municipality)**
Tender Reg.No : **2017/319840**
Bid Deadline : 31.05.2017
Winner : **AZİZOĞLU MOTORLU ARAÇ**
Approx. Cost : 8.746.521,00 TL
Contract cost : 8.376.300,00 TL
- **DMO I NOLU SATINALMA D.BSK; 21 ea 2017 Model Temsa Brand Buses (Mersin For Mersin M.Municipality)**
Tender Reg.No : **2017/319840**
Bid Deadline : 31.05.2017
Winner : **AZİZOĞLU MOTORLU ARAÇ**
Approx. Cost : 8.746.521,00 TL
Contract cost : 8.376.300,00 TL
- **DMO I NOLU SATINALMA D.BSK: 1 ea Temsa Bus**
Tender Reg.No : **2016/586598**
Bid Deadline : 15.12.2016
Winner : **AZİZOĞLU MOT. ARAÇLAR**
Approx. Cost : 415.842,00 TL
Contract cost : 395.000,00 TL
- **DMO I NOLU SATINALMA D.BSK;2 ea Bus**
Tender Reg.No : **2017/614069**
Bid Deadline : 21.11.2017
Winner : **AZİZOĞLU MOTORLU ARAÇ**
Approx. Cost : 1.087.008,00 TL
Contract cost : 1.027.000,00 TL
- **DMO I NOLU SATINALMA D.BSK; 1 ea Isuzu Brand Buses**
Tender Reg.No : **2017/524894**
Bid Deadline : 09.10.2017
Winner : **ANADOLU-ISUZU A.Ş**
Approx. Cost : 244.000,00 TL
Contract cost : 232.300,00 TL
- **DMO I NOLU SATINALMA D.BSK;3 ea Bus**
Tender Reg.No : **2017/429538**
Bid Deadline : 21.08.2017
Winner : **MERCEDES-BENZ TÜRK A.Ş**
Approx. Cost : 1.997.818,00 TL
Contract cost : 1.757.000,00 TL
- **DMO 1 NOLU SAT.D.BSK: 20 Ea 2016 Model Isuzu Novo Lux 27+1 passenger cap., buses with radio siren installed, flato, retarder, refrigerator, additional heating system free from engine**
Tender Reg.No : **2017/339484**
Bid Deadline : 28.04.2017
Winner : **ANADOLU-ISUZU A.Ş.**
Approx. Cost : 4.027.520,00 TL
Contract cost : 3.553.500,00 TL
- **DMO I NOLU SATINALMA D.BSK; 5 ea 2017 Model Bus**
Tender Reg.No : **2017/307591**
Bid Deadline : 31.05.2017
Winner : **MERCEDES-BENZ TÜRK AŞ**
Approx. Cost : 3.000.000,00 TL
Contract cost : 2.640.000,00 TL
- **DMO II NOLU SATINALMA D.BSK; 1 Ea Mercedes Benz Conecto Solo 12m Low bed diesel Standard bus.**
Tender Reg.No : **2017/173229**
Bid Deadline : 04.04.2017
Winner : **MERCEDES-BENZ TÜRK A.Ş**
Approx. Cost : 520.000,00 TL
Contract cost : 493.000,00 TL
- **DMO I NOLU SATINALMA D.BSK; For Mersin M.Municipality, 15 ea Mercedes Bus**
Tender Reg.No : **2017/648460**
Bid Deadline : 23.11.2017
Winner : **MERCEDES-BENZ TÜRK AŞ**
Approx. Cost : 7.350.000,00 TL
Contract cost : 7.117.500,00 TL
- **DMO I NOLU SATINALMA D.BSK; Mersin For Mersin M.Municipality 15 Ea Mercedes Benz Conecto Solo buses**
Tender Reg.No : **2017/628035**
Bid Deadline : 23.11.2017
Winner : **MERCEDES-BENZ TÜRK AŞ**
Approx. Cost : 7.350.000,00 TL
Contract cost : 7.117.500,00 TL
- **DMO I NOLU SATINALMA D.BSK; 1 Ea Temsa Bus**
Tender Reg.No : **2017/648703**
Bid Deadline : 28.12.2017
Winner : **AZİZOĞLU MOTORLU ARAÇLAR**
Approx. Cost : 170.577,00 TL
Contract cost : 164.000,00 TL
- **DMO I NOLU SATINALMA D.BSK;1 ea Bus, 2017 Model White Mercedes-Benz Turismo 15 Rhd model, with Euro 6 Motor (50+1+1)**
Tender Reg.No : **2017/635270**
Bid Deadline : 29.11.2017
Winner : **MERCEDES-BENZ TÜRK A.Ş**
Approx. Cost : 813.914,00 TL
Contract cost : 716.000,00 TL

CONSTRUCTION TENDERS

- ANKARA GOVERNORSHIP- YATIRIM İZLEME VE KOORDİNASYON BAŞKANLIĞI:** Akyurt 500 people cap. return centre

Tender Reg.No : **2016/512251**
 Bid Deadline : 26.12.2016
 Approx. Cost : 34.236.008,01 TL
 Limit value : 25.542.515,15 TL
 Winner : **KEMAL İNŞAAT TURİZM GIDA OTOMOTİV AKARYAKIT LTD**
 Contract Cost : 25.919.000,00 TL
- ANKARA-ASKİ:** P1 -AOÇ route drinking water supply lines

Tender Reg.No : **2017/63984**
 Bid Deadline : 08.03.2017
 Approx. Cost : 15.289.404,50 TL
 Limit value : 10.369.671,44 TL
 Winner : **ASİLPET PETROL**
 Contract Cost : 14.877.000,00 TL
- ANTALYA WATER AND SEWERAGE ADMIN. (ASAT):** Korkuteli water supply Project: Bids evaluated and board of directors decision being awaited.

Bid Method : Open
 Tender Reg.No : **2017/123949**
 Bid Deadline : 20.04.2017
 Approx. Cost : 41.666.681,60 TL
 Limit value : 24.675.319,96 TL
 Winner : **İLBA MİM İNŞ TURZ. LTD**
 Contract Cost : 28.280.000,00 TL
- ANKARA ASKİ - SU İNŞAAT DAİRESİ BAŞKANLIĞI:** city centre, districts and rural areas water depots maintenance and repairs, new depots and header centres

Bid Method : Open
 Tender Reg.No : **2017/112959**
 Bid Deadline : 04.04.2017
 Approx. Cost : 37.368.061,05 TL
 Limit value : 25.125.636,74 TL
 Winner : **ATEŞLER YAPI İNŞAAT. LTD.ŞTİ.**
 Contract Cost : 37.161.950,00 TL
- BALIKESİR M.MUNICIPALITY KENT ESTETİĞİ DAİRESİ BAŞKANLIĞI:** Camlik Hill 261827 M2 recreational area arrangement

Bid Method : Open
 Tender Reg.No : **2016/512398**
 Bid Deadline : 05.01.2017
 Approx. Cost : 153.815.943,88 TL
 Limit value : 118.085.967,77 TL
 Winner : **ÖZGÜN YAPI A.Ş., BAYBURT GRUP İNŞAAT A.Ş.**
 Contract Cost : 135.903.285,21 TL
- DSİ 11. BÖLGE MÜDÜRLÜĞÜ:** Edirne İpsala-Karaağaç Pond and irrigation facilities

Bid Method : Open
 Tender Reg.No : **2016/548380**
 Bid Deadline : 05.01.2017
 Approx. Cost : 22.583.396,05 TL
 Limit value : 17.071.117,75 TL
 Winner : **HASELSAN İNŞAAT A.Ş.- LİBAŞ MÜTEAHLİK A.Ş.**
 Contract Cost : 17.446.027,45 TL
- DSİ 11. BÖLGE MÜDÜRLÜĞÜ:** Kırklareli Pınarhisar Yenice Pond and irrigation facilities

Tender Reg.No : **2016/542525**
 Bid Deadline : 05.01.2017
 Approx. Cost : 21.694.920,81 TL
 Limit value : 15.887.406,12 TL
 Winner : **GÜLAK TAAHHÜT LTD. EREZ İNŞAAT A.Ş.**
 Contract Cost : 16.934.324,79 TL
- DSİ - PROJE VE İNŞAAT DAİRESİ BAŞKANLIĞI- ANKARA:** Şanlıurfa-Bozova pumping irrigation 2nd stage areas remaining under the main channel and Tekağaç irrigation facilities

Tender Reg.No : **2016/607137**
 Bid Deadline : 07.02.2017
 Approx. Cost : 16.817.643,24 TL
 Limit value : 13.341.258,93 TL
 Winner : **İZGÜL MÜH.İNŞAAT LTD.ŞTİ**
 Contract Cost : 14.920.000,00 TL
- DSİ - PROJE VE İNŞAAT DAİRESİ BAŞKANLIĞI:** DSİ 7. Bölge (Samsun) Aşağı Çekerek I Merhale Zile, Maşat, Reşadiye, Çekerek and Mamure Plains irrigation facilities 1st stage .

Tender Reg.No : **2016/576977**
 Bid Deadline : 31.01.2017
 Approx. Cost : 44.775.677,34 TL
 Limit value : 33.455.682,67 TL
 Winner : **ÖZ ER-KA İNŞ. AŞ.-ASİL İNŞAAT A.Ş.**
 Contract Cost : 34.395.800,00 TL
- DSİ - PROJE VE İNŞAAT DAİRESİ BAŞKANLIĞI- ANKARA:** In Edirne Provincial Borders Çakmak Dam irrigation 1st stage works

Tender Reg.No : **2016/581363**
 Bid Deadline : 28.02.2017
 Approx. Cost : 119.587.052,81 TL
 Limit value : 90.198.226,47 TL
 Winner : **MEHMET ALPTEKİN**
 Contract Cost : 91.063.254,28 TL
- DSİ - PROJE VE İNŞAAT DAİRESİ BAŞKANLIĞI:** Kralkızı-Dicle P-3 pumping irrigation supply lines . pumping station and trunk main constr. (For irrigation of 23965,35 ha area 5.437.86m supply lines, pumping station and 71.350.05 m P3 trunk main and artifacts constr..)

Tender Reg.No : **2016/603859**
 Bid Deadline : 07.03.2017-14.30
 Work period : 400 takvim günü
 Approx. Cost : 247.838.285,11 TL
 Limit value : 189.345.565,62 TL
 Tender was canceled.
- DSİ - PROJE VE İNŞAAT DAİRESİ BAŞKANLIĞI:** Kralkızı-Dicle P-3 pumping irrigation. (For irrigation of 23965,35 ha area piped network and artifacts constr)

Tender Reg.No : **2016/592254**
 Bid Deadline : 01.03.2017-14.30
 Approx. Cost : 79.725.279,46 TL
 Limit value : 60.610.153,85 TL
 Winner : **CEYLAN İNŞAAT A.Ş.**
 Contract Cost : 67.500.349,00 TL

- **DSİ -18. BÖLGE MÜDÜRLÜĞÜ: (Isparta)Afyonkarahisar Çay Selevir irrigation renewal constr.(Akkonak Kasabası, KaramıkKaracaören Kasabası, Pazaragaç Kasabası, Maltepe Köyü, Kadıköy Cumhuriyet Köyü, Orhaniye Köyü)**
Tender Reg.No : 2016/581326
Bid Deadline : 07.02.2017
Approx. Cost :44.977.098,73 TL
Limit value : 33.533.961,35 TL
Winner : **ETHAŞ TARIM A.Ş. ENSAR İNŞAAT LTD**
Contract Cost : 37.220.000,00 TL
- **DSİ 20.BÖLGE MÜDÜRLÜĞÜ (K.MARAS):Kılavuzlu Irrigation facilities 4th stage**
Tender Reg.No : 2017/180531
Bid Deadline : 30.05.2017
Approx. Cost : 116.315.323,87 TL
Limit value : 87.515.111,08 TL
Winner : **AK-YAL İNŞAAT LTD.**
Contract Cost : 90.775.000,00 TL
- **DSİ 9.BÖLGE MÜDÜRLÜĞÜ (ELAZIĞ):Uluova Irrigation facilities 1.stage**
Bid Method : Open
Tender Reg.No : 2017/178441
Bid Deadline : 30.05.2017
Approx. Cost : 56.553.841,69 TL
Limit value : 44.861.124,70 TL
Winner : **HASELSAN İNŞ A.Ş.**
Contract Cost : 45.500.000,00 TL
- **DSİ- 21. BÖLGE MÜDÜRLÜĞÜ: Denizli drinking water main lines.**
Tender Reg.No :2017/171726
Bid Deadline : 12.05.2017
Approx. Cost : 29.868.984,00 TL
Limit value : 24.166.131,56 TL
Winner : **KAMER İNŞ LTD.ŞTİ.**
Contract Cost : 27.490.000,00 TL
- **DSİ 5.BÖLGE MÜDÜRLÜĞÜ-ANKARA: Bolu-Göynük Hasanlar and Dedeler Ponds constr.**
Bid Method : Open
Tender Reg.No : 2017/313859
Bid Deadline : 27.07.2017
Approx. Cost : 29.058.708,21 TL
Limit value : 19.505.943,00 TL
Winner : **BERGİZ İNŞ A.Ş, BİLGİN TAAH. LTD.**
Contract Cost : 19.666.000,00 TL
- **DSİ 21.BÖLGE MÜDÜRLÜĞÜ (AYDIN) Boğalar Seki Dam completion (clay cored rock filled type with height from thalweg 58 mt. for irrigation purposes.)**
Tender Reg.No : 2017/171712
Bid Deadline : 22.05.2017-10.00
Approx. Cost : 89.924.957,10 TL
Limit value : 70.666.957,85 TL
Winner : **SİSTEM ELEKTROMEKANİK A.Ş, KARACA İNŞ A.Ş.**
Contract Cost : 73.000.000,88 TL
- **DSİ - 5. Bölge Müdürlüğü-ANKARA: Ankara-Bala Evciler Pond completion**
Tender Reg.No :2016/605416
Bid Deadline : 13.02.2016
Approx. Cost :20.228.515,85 TL
Limit value : 14.509.487,01 TL
Winner : **SERBİL İNŞAAT A.Ş.**
MAGNESİA YAPI LTD.
Contract Cost : 15.505.320,31 TL
- **İSTANBUL M.MUNICIPALITY- YAPI İŞLERİ MÜDÜRLÜĞÜ: Gaziosmanpaşa Merkez Mahallesi squares, sports areas, underground car parks .**
Tender Reg.No : 2016/495549
Bid Deadline : 05.01.2017
Approx. Cost : 66.330.706,88 TL
Limit value : 48.002.971,16 TL
Winner : **HİSAR İNŞAAT TAAHHÜT**
Contract Cost : 50.300.000,00 TL
- **İSTANBUL M.MUNICIPALITY- FEN İŞLERİ MÜDÜRLÜĞÜ: Üsküdar square landscaping works**
Tender Reg.No : 2016/490512
Bid Deadline : 29.12.2016
Approx. Cost : 93.668.415,93 TL
Winner : **ŞİMŞEKLER İNŞAAT A.Ş. , MİRAÇ-YOL ALTYAPI A.Ş.**
Contract Cost : 72.614.833,30 TL
- **İZMİR M.MUNICIPALITY İZBETON A.Ş: İzmir various streets hot asphaltting coating and maintenance**
Tender Reg.No : 2016/456038
Bid Deadline : 04.01.2017
Approx. Cost : 73.669.889,94 TL
Winner : **BARANKAYA İNŞAAT-YAPIMAKS İNŞAAT-KMB METRO İNŞ.**
Contract Cost : 53.459.679,00 TL
- **İSTANBUL İSKİ GENEL MÜDÜRLÜĞÜ: Anatolian side 70.000 mt. ductile font (Ø 100-Ø600 mm), 12.000 mt steel (Ø 600-Ø1200 mm) and 2.000 mt HDPE (Ø 110-Ø315 mm) drinking water pipeline constr.)**
Tender Reg.No : 2016/529416
Bid Deadline : 12.01.2017
Approx. Cost : 29.051.343,00 TL
Limit value : 18.835.343,51 TL
Winner : **GURBETOĞLU İNŞ A.Ş.**
Contract Cost : 25.414.840,00 TL
- **İSTANBUL M.MUNICIPALITY -ALTYAPI HİZMETLERİ MÜDÜRLÜĞÜ: D-100 land road Pendik Junc. Çayırova Junc. route side roads arrangements**
Tender Reg.No : 2016/583309
Bid Deadline : 28.02.2017
Approx. Cost : 86.356.908,38 TL
Limit value : 52.097.822,69 TL
Winner : **MUZAFFER OFLAZ, TRANS-OF ULUSAL NAK. İNŞ LTD**
Contract Cost : 61.438.140,00 TL
- **İSTANBUL M.MUNICIPALITY -ALTYAPI HİZMETLERİ MÜDÜRLÜĞÜ:D-100 Karayolu Büyükyalı Junc.-Pendik Junc. route side roads arrangements**
Tender Reg.No : 2017/7846
Bid Deadline : 28.02.2017
Approx. Cost : 73.945.333,08 TL
Limit value : 46.036.311,77 TL
Winner : **MAK İŞ İNŞ., GENÇ YILDIZ İNŞ**
Contract Cost : 55.775.700,00TL
- **İLLER BANKASI A.Ş.- YATIRIM KOORDİNASYON DAİRESİ BAŞKANLIĞI-Baklan (Denizli) Drinking water , storm water , sewerage and wastewater treatment plant**
Tender Reg.No : 2016/555524
Bid Deadline : 16.01.2017
Approx. Cost : 30.614.230,35 TL
Limit value : 20.108.128,57 TL
Winner : **GÜVENÇ YAPI LTD**
YENİDOĞUŞ İNŞAAT. LTD.
Contract Cost : 20.139.116,74 TL

- **İLLER BANKASI A.S. Yatırım Koordinasyon Dairesi**
Başkanlığı-ANKARA: Serinhisar (Denizli) drinking water, sewerage and storm water works
Bid Method : Open
Tender Reg.No : **2017/2626**
Bid Deadline : 21.02.2016
Approx. Cost : 43.295.799,02 TL
Limit value : 27.927.180,17 TL
Winner : **FETVACI KARDEŞLER LTD.**
Contract Cost : 25.280.314,25 TL
- **İSTANBUL M.MUNICIPALITY:** Tuzla Bazaar constr.
Bid Method : Open
Tender Reg.No : **2016/582477**
Bid Deadline : 19.06.2017
Approx. Cost : 517.367.206,25 TL
Limit value : 431.427.850,16 TL
Winner : **İNTEKAR YAPI LTD.-DİDO-RAY YAPI A.Ş, METALEKS İNŞ A.Ş.**
Contract Cost : 548.395.000,00 TL
- **İSTANBUL WATER AND SEWERAGE ADMIN.:** Asian side concrete pipelines renewal (3).
Bid Method : Open
Tender Reg.No : **2017/22381**
Bid Deadline : 17.07.2017
Approx. Cost : 155.715.922,68 TL
Limit value : 104.632.111,72 TL
Winner : **GURBETOĞLU İNŞ. A.Ş.**
KİSKA-KOM İNŞ A.Ş.
Contract Cost : 153.917.277,11 TL
- **İSTANBUL M.MUNICIPALITY:** Kadıköy Fikirtepe transport roads joint infrastructures.
Tender Reg.No : **2016/262639**
Bid Deadline : 20.07.2017
Approx. Cost : 201.189.440,09 TL
Limit value : 134.462.825,87 TL
Winner : **KALYON İNŞ A.Ş.**
Contract Cost : 194.350.034,13 TL
- **İSTANBUL M.MUNICIPALITY:** Kadıköy Fikirtepe transport roads joint infrastructure constr.
Tender Reg.No : **2016/262639**
Bid Deadline : 20.07.2017
Approx. Cost : 201.189.440,09 TL
Limit value : 134.462.825,87 TL
Winner : **KALYON İNŞAAT A.Ş.**
Contract Cost : 194.350.034,13 TL
- **İSTANBUL WATER AND SEWERAGE ADMIN. (İSKİ):** Water basins maintenance cleaning.
Tender reg.no : **2017/372664**
Bid deadline : 12.09.2017
Winner : **AHMET KİBRİTÇİ**
Approx. Cost : 12.308.995,96 TL
Contract cost : 8.451.242,56 TL
- **JUSTICE MINISTRY TEKNİK İŞLER DAİRESİ**
BAŞKANLIĞI-ANKARA: Bolvadin (Afyonkarahisar) T type penitentiary house constr.
Bid Method : Auction
Tender Reg.No : **2017/96851**
Bid Deadline : 14.03.2017
Approx. Cost : 91.176.022,32 TL
Winner : **METOL NAKL. TAAH. LTD.- Y-DOĞUŞ LTD.**
Contract Cost : 81.400.000,00 TL
- **JUSTICE MINISTRY :** Tokat annex facilities constr.
Bid Method : Open
Tender Reg.No : **2016/517622**
Bid Deadline : 26.12.2016
Approx. Cost : 23.881.393,15 TL
Limit value : 17.553.502,45 TL
Winner : **ADA YAPI A.Ş.**
Contract Cost : 18.326.000,00 TL
- **JUSTICE MINISTRY- TEKNİK İŞLER DAİRESİ**
BAŞKANLIĞI-ANKARA: Yozgat Personnel training centre
Bid Method : Open
Tender Reg.No : **2017/47364**
Bid Deadline : 22.02.2016
Approx. Cost : 69.361.511,25 TL
Limit value : 53.462.096,00 TL
Winner : **AYSOY İNŞ SAN LTD.ŞTİ.**
Contract Cost : 54.650.000,00 TL
- **PETROLEUM PIPELINES CO. (BOTAS) :** Gümüşhane Kelkit District naturalgas pipelines. (total 29.492 metre (slopy distance) 6 inch in diam. high pressure steel pipeline sys.)
Bid Method : Open
Tender Reg.No : **2016/551877**
Bid Deadline : 10.01.2017
Approx. Cost : 7.933.264,00 TL
Limit value : 5.229.146,60 TL
Winner : **SİLVER TEKNİK İNŞ A.Ş.**
Contract Cost : 5.230.816,95 TL
- **STATE HIGHWAYS- PROGRAM VE İZLEME DAİRESİ**
BAŞKANLIĞI-ANKARA: (Ardahan-Cıldır) Junc...-Posof-Türkçözü road Km:0+000-41+000 section constr.
Bid Method : Preselection
Tender Reg.No : **2016/320323**
Bid Deadline : 26.12.2016
Approx. Cost : 430.695.524,02 TL
Limit value : 328.253.702,44 TL
Winner : **PERS YAPI-ASTRO ÜSTYAPI**
Contract Cost : 335.831.405,36 TL
- **SPORTS GENERAL DIRECTORATE (SGM)- GENÇLİK TESİSLER DAİRESİ BAŞKANLIĞI:** Adıyaman Kahta Sports complex
Tender Reg.No : **2016/516141**
Bid Deadline : 26.12.2016
Approx. Cost : 26.725.917,75 TL
Limit value : 19.288.908,94 TL
Winner : **VİT VAROL İNŞAATÇİCARET**
Contract Cost : 19.733.000,00 TL
- **STATE HYDRAULIC WORKS-DSİ- 5.BÖLGE MÜDÜRLÜĞÜ-ANKARA:** Ankara Kazan District Ova stream flood control facilities
Tender Reg.No : **2016/530071**
Bid Deadline : 28.12.2016
Approx. Cost : 21.353.388,21 TL
Limit value : 13.602.680,79 TL
Winner : **MUZAFFER KAYGIN İNŞAAT**
Contract Cost : 13.665.582,60 TL
- **STATE HYDRAULIC WORKS:** Gaziantep-Düzbağıdrinking water water main lines constr.
Tender Reg.No : **2016/580855**
Bid Deadline : 30.12.2016
Approx. Cost : 947.327.456,65 TL
Limit value : 750.960.652,59 TL
Winner : **KALYON İNŞAAT A.Ş.**
Contract Cost : 898.000.000,00 TL

- **STATE HIGHWAYS ADMIN. (KGM)-6.BÖLGE MÜDÜRLÜĞÜ (KAYSERİ):** Alaca-Zile (7.Regional border - Aydıncık junc.-7.Regional border route) Km:23+600-55+496,65 route soil levelling artifacts. superstructure and
 Tender Reg.No : 2016/538056
 Bid Deadline : 10.01.2017
 Approx. Cost : 120.232.065,94 TL
 Limit value : 78.560.065,95 TL
 Winner : ACS İNŞ MAD A.Ş. ÖRENSAN
 Contract Cost : 78.998.413,00 TL
- **STATE HIGHWAYS ADMIN. (KGM)-2. BÖLGE MÜDÜRLÜĞÜ (İZMİR):**Uşak-Sivaslı-(Denizli-Çardak) junc. road Yolu (Km:0+000-56+416) route soil levelling artifacts, superstructure and BSK
 Tender Reg.No : 2016/556282
 Başvuru tarihi : 12.01.2017
 Approx. Cost : 160.860.326,88 TL
 Limit value : 100.386.734,51 TL
 Winner : YAZICIOĞLU NAKLİYAT
 Contract Cost : 100.397.170,00 TL
- **STATE HIGHWAYS ADMIN. (KGM)- PROGRAM VE İZLEME DAİRESİ BAŞKANLIĞI-ANKARA:** (Çorum-Merzifon) junc.-Mecitözü- (Amasya-Turhal) junc. road Km: 0+000-61+841,27 section constr..
 Tender Reg.No : 2016/311417
 Bid Deadline : 12.01.2017
 Approx. Cost : 309.427.971,88 TL
 Limit value : 240.800.496,82 TL
 Winner : YEDİGÖZE İNŞAAT LTD.
SİGMA A.Ş.
 Contract Cost : 247.085.931,65 TL
- **JUSTICE MINISTRY - TEKNİK İŞLER DAİRESİ BAŞKANLIĞI:** Mersin Erdemli Justice facilities constr. .
 Tender Reg.No : 2016/566119
 Bid Deadline : 10.01.2017
 Approx. Cost : 23.590.556,80 TL
 Winner : ORC İNŞAAT SAN.VE TİC.A.Ş.,
MEHMET ALİ ORUÇ
 Contract Cost : 17.285.000,00 TL
- **MINISTRY OF TRANSPORT AND MARITIME:** Coast Guard Command's Black Sea Regional Command's dock extension by 30 m and South dock arrangements.
 Tender Reg.No : 2017/159395
 Bid Deadline : 02.05.2017
 Approx. Cost : 22.478.909,83 TL
 Limit value : 17.641.952,46TL
 Winner : ADSEL İNŞAAT TİC.LTD.
 Contract Cost : 21.071.000,00 TL
- **STATE HYDRAULIC WORKS-4.BÖLGE MÜDÜRLÜĞÜ:** Konya Ereğli district İvriz right bank irrigation renewal
 Tender Reg.No : 2016/521880
 Bid Deadline : 12.01.2017
 Approx. Cost : 250.750.000,00 TL
 Limit value : 184.709.467,01 TL
 Winner : AGE İNŞAAT VE TİCARET A.Ş.
 Contract Cost : 191.949.800,00 TL
- **STATE HIGHWAYS ADMIN. (KGM)- PROGRAM VE İZLEME DAİRESİ BAŞKANLIĞI-ANKARA:** Muğla-Kale-Tavas-Denizli junc. road. Km: 75+000-116+300 section works.
 Tender Reg.No : 2016/545412
 Bid Deadline : 17.01.2017
 Approx. Cost : 62.234.810,44 TL
 Winner : FEZA TAAHHÜT A.Ş.
 Contract Cost : 38.487.013,13 TL
- **STATE HYDRAULIC WORKS -PROJE VE İNŞAAT DAİRESİ BAŞKANLIĞI-ANKARA:**Kralkızı-Dicle P-4 pumping irrigation facilities
 Tender Reg.No : 2016/471106
 Bid Deadline : 17.01.2017
 Approx. Cost : 132.450.122,13 TL
 Limit value : 95.362.607,84 TL
 Winner : SERFEN İNŞAAT A.Ş. BEST
TASARIM A.Ş.
 Contract Cost : 99.423.000,00 TL
- **STATE HYDRAULIC WORKS -PROJE VE İNŞAAT DAİRESİ BAŞKANLIĞI:**Değirmençay Dam constr..(6. Bölge md. Adana)
 Bid Method : Open
 Tender Reg.No : 2016/552944
 Bid Deadline : 17.01.2017
 Approx. Cost : 197.629.749,86 TL
 Limit value : 124.088.734,55 TL
 Winner : BRJ İNŞAAT SANAYİ VE TİC.
 Contract Cost : 122.792.342,90 TL
- **STATE HYDRAULIC WORKS- PROJE VE İNŞAAT DAİRESİ BAŞKANLIĞI-ANKARA:** Hatay-Reyhanlı Dam irrigation constr 1.stage
 Bid Method : Open
 Tender Reg.No : 2016/439256
 Bid Deadline : 18.01.2017
 Approx. Cost : 81.971.110,67 TL
 Limit value : 61.375.618,04 TL
 Winner : PALET İNŞAAT A.Ş.
 Contract Cost : 64.912.878,85 TL
- **STATE HIGHWAYS ADMIN. (KGM)-GENEL MÜDÜRLÜĞÜ PROGRAM VE İZLEME DAİRESİ BAŞKANLIĞI-ANKARA:** Kalkan-Fethiye-2.bl. Hd. road Km:0+215-51+310 (Uğurlu Kavsağı-Kalkan) route
 Bid Method : Preselection
 Tender Reg.No : 2016/364122
 Bid Deadline : 18.01.2017
 Approx. Cost : 244.857.966,44 TL
 Limit value : 188.216.610,22 TL
 Winner : POLAT YOL YAPI A.Ş.
 Contract Cost : 189.487.000,33 TL
- **STATE HYDRAULIC WORKS- ;Osmaniye Savrun Dam constr.**
 Bid Method : Open
 Tender Reg.No : 2016/548588
 Bid Deadline : 19.01.2017
 Approx. Cost : 119.991.561,83 TL
 Limit value : 73.761.695,97 TL
 Winner : ÖZALTIN İNŞAAT A.Ş.
 Contract Cost : 73.553.250,00 TL
- **STATE HIGHWAYS ADMIN. (KGM)-10. BÖLGE MÜDÜRLÜĞÜ:** Trabzon-Aşkale (Dap) (Dokap) road. Kale-Maden-12bl Hd road Km: 123+543g / 127+545i-198+300g / 52+023i-37+800 route (Vauk tunnel incl.) route soil levelling artifacts, bridge and superstructure and (Bsk)
 Bid Method : Open
 Tender Reg.No : 2016/318189
 Bid Deadline : 24.01.2017
 Approx. Cost : 633.359.110,10 TL
 Limit value : 491.390.898,64 TL
 Winner : ŞENBAY MAD. + EDERAY
İNŞAAT + UĞURSAL ELEKTRİK
 Contract Cost : 506.335.066,20 TL

- **STATE HIGHWAYS ADMIN. (KGM)-14.BÖLGE MÜDÜRLÜĞÜ (BURSA):** Çan-Yenice-Balya route soil levelling, superstructure and bridge
Tender Reg.No : 2016/581210
Bid Deadline : 25.01.2017
Approx. Cost : 118.904.093,42 TL
Limit value : 73.767.766,45 TL
Winner : **KARFEN İNŞAAT A.Ş.**
Contract Cost : 73.646.171,00 TL
- **STATE HIGHWAYS ADMIN. (KGM)-4.BÖLGE MÜDÜRLÜĞÜ (ANKARA)**Eskişehir-Alpu-Mihalıççık road Km: 0+000-39+300 route soil levelling artifacts, superstructure and, bridge constr.: 56 offers received
Bid Method : Open
Tender Reg.No : 2016/576853
Bid Deadline : 30.01.2017
Approx. Cost : 103.367.665,90 TL
Limit value : 64.017.999 56 TL
Winner : **EMİROĞLU İNŞAAT TİC.LTD.**
Contract Cost : 63.950.861,00 TL
- **STATE HIGHWAYS ADMIN. (KGM)-4.BÖLGE MÜDÜRLÜĞÜ (ANKARA)**(Bolu-Seben) junc. Kıbrısçık road Km:29+300-35+774 ve km:35+774-37+000 route connecting road soil levelling artifacts, superstructure and, bridge constr and km:25+000-29+300 route completion
Tender Reg.No : 2016/573846
Bid Deadline : 01.02.2017
Approx. Cost : 27.675.359,60 TL
Limit value : 17.640.389,22 TL
Winner : **ORAK ALTYAPI SANAYİ A.Ş.**
Contract Cost : 17.640.850,00 TL
- **STATE HIGHWAYS ADMIN. (KGM)-4.BÖLGE MÜDÜRLÜĞÜ (ANKARA)**Ankara-Kahramankazan road (peripheral road junc.-Kahramankazan route) (Km: 21+200-49+606,95 route) route soil levelling artifacts, superstructure and, bridge constr.
Tender Reg.No : 2016/575779
Bid Deadline : 31.01.2017
Approx. Cost : 457.972.463,08 TL
Limit value : 283.320.571,61 TL
Winner : **ÖZGÜN YAPI A.Ş.-BAYBURT GRUP A.Ş.**
Contract Cost : 284.195.826,00 TL
- **STATE HIGHWAYS ADMIN. (KGM)-2.BÖLGE MÜDÜRLÜĞÜ (İZMİR):** Söke-Koçarlı (Aydın-Çine) junc. route soil levelling artifacts, superstructure constr
Bid Method : Open
Tender Reg.No : 2016/590406
Bid Deadline : 06.02.2017
Approx. Cost : 151.856.356,31 TL
Limit value : 93.155.734,02 TL
Winner : **DOĞUSAN İNŞAAT A.Ş.**
Contract Cost : 93.156.144,67 TL
- **STATE HIGHWAYS ADMIN. (KGM)-3.BÖLGE MÜDÜRLÜĞÜ (KONYA):** Akşehir-Yunak-4.Bölge state road Km:21+000-56+350 route soil levelling artifacts
Bid Method : Open
Tender Reg.No : 2016/601551
Bid Deadline : 06.02.2017
Approx. Cost : 99.273.845,46 TL
Limit value : 61.555.256,79 TL
Winner : **ÖREN YAPI SAN. VE TİC.**
Contract Cost : 61.581.970,00 TL
- **STATE HIGHWAYS ADMIN. (KGM)-: Sanliurfa-Bozova-Adiyaman road Karababa bridge constr.:** Bids in.
Tender Reg.No : 2017/12022
Bid Deadline : 16.02.2016
Winner : **YAZICIOĞLU NAK. İNŞ A.Ş.**
Contract Cost : 48.880.800,00 TL
- **STATE HYDRAULIC WORKS- Proje ve İnşaat Dairesi Başkanlığı:** Mardin storage gravity irrigation facilities constr.
Tender Reg.No : 2016/587190
Bid Deadline : 14.02.2016
Approx. Cost : 276.397.709,39 TL
Limit value : 182.200.997,22 TL
Winner : **ENKAYA İNŞAAT., KALEM İNŞ**
Contract Cost : 182.812.728,15 TL
- **STATE HIGHWAYS ADMIN. (KGM)-Genel Müdürlüğü Program ve İzleme Dairesi Başkanlığı:** Tatvan peripheral road Km: 0+000-10+237,52 section constr..
Tender Reg.No : 2016/425361
Bid Deadline : 13.02.2016
Approx. Cost : 183.538.414,14 TL
Limit value : 119.663.380,61 TL
Winner : **SDB MAD. LTD. TBM YAPI**
Contract Cost : 120.517.164,80 TL
- **STATE HYDRAULIC WORKS- :** Bünyan Elbaşı-Karadağ irrigation facilities
Tender Reg.No : 2016/595842
Bid Deadline : 23.02.2017-14.30
Approx. Cost : 81.975.157,48 TL
Limit value : 57.797.330,52 TL
Winner : **KALEM NAKLİYE İNŞ LTD.**
Contract Cost : 58.832.166,54 TL
- **STATE HIGHWAYS ADMIN. (KGM)-6. BÖLGE MÜDÜRLÜĞÜ:**Derevenk (Mimarsinan) viaduct and connecting roads
Tender Reg.No : 2017/70699
Bid Deadline : 17.02.2016
Approx. Cost : 130.051.752,48 TL
Winner : **BARVA MÜŞ. İNŞ. A.Ş.-BEKİRHAN İNŞ. SAN. LTD.ŞTİ.**
Contract Cost : 98.769.915,80 TL
- **STATE RAILWAYS ADMIN.-(TCDD):** Ankara İstanbul High speed train project (YHT)'s T26 sections connection works.
Tender Reg.No : 2017/27490
Bid Deadline : 22.02.2016
Approx. Cost : 890.863.591,20 TL
Winner : **CENGİZ İNŞAAT+İÇTAŞ İNŞ**
Contract Cost : 792.869.080,00 TL
- **STATE HIGHWAYS ADMIN. (KGM)- PROGRAM VE İZLEME DAİRESİ BAŞKANLIĞI-ANKARA** (Malatya-Elbistan) junc.-Yazıhan-Hekimhan-Kanqal road Tohma Bridge constr.
Tender Reg.No : 2017/12658
Bid Deadline : 28.02.2017
Approx. Cost : 53.348.985,68 TL
Winner : **ZİVER İNŞAAT A.Ş.**
Contract Cost : 47.474.474,47 TL
- **STATE HIGHWAYS ADMIN. (KGM)-16.BÖLGE MÜDÜRLÜĞÜ (SİVAS):** (Yıldızeli-Sivas) Junc.-Direkli-Bedirli-Hanlı road Km:0+000-46+010 route soil levelling artifacts, superstructure constr
Tender Reg.No : 2017/46230
Bid Deadline : 08.03.2017
Approx. Cost : 110.106.501,88 TL
Winner : **ZİVER İNŞAAT A.Ş.**
Contract Cost : 72.072.072,72 TL

- STATE HIGHWAYS ADMIN. (KGM)- TRNC's (Lefkoşa-Gazimağusa) Junc.-Değirmenlik-(Girne-Esentepe) Junc road Demirhan-Değirmenlik road, Girne East peripheral road, Girne Junc -Esentepe-Gecitkale road, Tatlısu-Kaplıca-Büyükkonuk road, Girne-Lefkoşa road constr. reinforcement**

Tender Reg.No : **2017/20803**
 Bid Deadline : 27.02.2017-14.30

1.ITEM (Lefkoşa-Gazimağusa)Junc.-Değirmenlik-(Girne-Esentepe) Junc. road. Km: 0+000-17+209,47 route and Demirhan-Değirmenlik road's Km: 0+000-9+000 sections constr. and reinforcement

Approx. Cost :158.943.475,20 TL
 Limit value :109.709.925,77 TL
 Winner : **PROYAP İNŞAAT**
 Contract Cost : 116.674.136,25 TL

2. ITEM (Girne East peripheral road Km: 0+000-8+997,17 section constr. reinforcement

Approx. Cost :84.911.878,96 TL
 Limit value :59.169.154,26 TL
 Winner : **İNTEKAR YAPI LTD.ŞTİ.**
 Contract Cost : 59.452.391,15 TL

3. ITEM (Girne Junc.-Esentepe-Gecitkale and Tatlısu-Kaplıca-Büyükkonuk roads and Girne-Lefkoşa route sections superstructure constr. reinforcement

Approx. Cost : 20.052.556,45 TL
 Limit value :13.388.078,83 TL
 Winner : **GLS MÜHENDİSLİK A.Ş. ÜNAL AKPINAR İNŞ A.Ş.**
 Contract Cost : 13.628.750,35 TL
- STATE HIGHWAYS ADMIN. (KGM)- PROGRAM VE İZLEME DAİRESİ BAŞKANLIĞI-ANKARA: Gelibolu-Eceabat divided road Km:149+800-197+250 route constr. reinforcement**

Tender Reg.No :**2016/457953**
 Bid Deadline : 28.02.2017
 Approx. Cost : 607.135.116,75 TL
 Limit value :470.764.217, 14 TL
 Winner : **BARVA MÜŞ, CENGİZ İNŞAAT**
 Contract Cost : 482.514.927,00 TL
- STATE HIGHWAYS ADMIN. (KGM)- PROGRAM VE İZLEME DAİRESİ BAŞKANLIĞI-ANKARA:YeniKent-Temelli road (energy lines displacements incl.) Km: 0+000-39+699,79 constr. reinforcement**

Bid Method : Preselection
 Tender Reg.No : **2016/476846**
 Bid Deadline : 01.03.2017
 Approx. Cost : 320.130.435,71 TL
 Limit value : 247.221.427,84 TL
 Winner : **ONUR TAAHHÜT A.Ş.+ YEDİGÖZE İNŞAAT LTD.**
 Contract Cost : 249.847.586,50 TL
- STATE HIGHWAYS ADMIN. (KGM)- PROGRAM VE İZLEME DAİRESİ BAŞKANLIĞI-ANKARA: Divarbakır-Siverek-Hilvan road Km: 50+000-120+000 route soil levelling artifacts, superstructure constr.**

Bid Method : Preselection
 Tender Reg.No : **2016/324184**
 Bid Deadline : 07.03.2017
 Approx. Cost : 167.502.631,95 TL
 Limit value : 133.715.528,23 TL
 Winner : **CEYLAN İNŞAAT A.Ş. ULUOVA İNŞAAT LTD.**
 Contract Cost : 134.850.007,11
- STATE HIGHWAYS ADMIN. (KGM)- PROGRAM VE İZLEME DAİRESİ BAŞKANLIĞI-ANKARA: (Malatya-Darende) junc.-Gölbaşı-5. Bl. Hd. road (2. stage) Km: 80+000-127+765 section works: Bids received.**

Bid Method : Preselection
 Tender Reg.No : **2016/456287**
 Date for Applic. : 30.11.2016
 Bid Deadline : 13.03.2017-14.30
 Approx. Cost : 138.257.426,04 TL
 Limit value : 88.940.761,84 TL
 Winner : **ÖZKA İNŞ A.Ş.-YÜKSEL İNŞ. A.Ş.-GÖKDELEN İNŞ. LTD.**
 Contract Cost : 89.100.313,00 TL
- STATE HIGHWAYS ADMIN. (KGM)- PROGRAM VE İZLEME DAİRESİ BAŞKANLIĞI: Kayseri-Niğde State road (Garıpçe Junc.-Bor Junc route) (Yahyalı Junc roadincl.) km:10+200-119+400 route soil levelling artifacts, superstructure constr.**

Tender Reg.No : **2016/472572**
 Bid deadline : 15.03.2017
 Approx. Cost : 310.223.807,36 TL
 Limit value : 239.540.333,23 TL
 Winner : **ÖZALTIN İNŞ A.Ş.**
 Contract Cost : 247.764.985,00 TL
- STATE HIGHWAYS ADMIN. (KGM)-5.BÖLGE MÜDÜRLÜĞÜ (MERSİN): (Adana-İmamoğlu) Junc.-Aladağ road Km:0+000-52+500 route soil levelling artifacts, superstructure constr. with Akören connection included**

Tender Reg.No : **2017/37240**
 Bid Deadline : 15.03.2017
 Approx. Cost : 50.985.710,60 TL
 Limit value : 32.161.301,93 TL
 Winner : **AYK YOL YAPI A.Ş.- ÖZAYKUTLAR NAK. İNŞ LTD.**
 Contract Cost : 32.363.988,00 TL
- STATE HIGHWAYS ADMIN. (KGM)-7. BÖLGE MÜDÜRLÜĞÜ-SAMSUN (Ordu-Topçam) junc.-Ulubey-Gürgentepe-Gölköy road Km:28+918,59-58+555,47 route soil levelling artifacts, superstructure constr (Bsk).**

Tender Reg.No : **2016/430923**
 Bid Deadline : 17.03.2017
 Approx. Cost : 133.317.819,40 TL
 Limit value : 85.742.471,78 TL
 Winner : **BARVA MÜŞ.DAN. İNŞ. A.Ş.- ADABAĞ YAPI A.Ş.**
 Contract Cost : 85.786.500,00 TL
- JUSTICE MINISTRY-TEKNİK İŞLER DAİRESİ BAŞKANLIĞI-ANKARA: Kars open penitentiary house constr.**

Tender Reg.No : **2017/97286**
 Bid Deadline : 16.03.2017
 Approx. Cost : 36.266.355,16 TL
 Winner : **RG İNŞAAT**
 Contract Cost : 35.336.000,00 TL
- STATE HIGHWAYS ADMIN. (KGM)-4. BÖLGE MÜDÜRLÜĞÜ-ANKARA: (Düzce-Akçakoca) Junc.-Yığılca road Km: 11+360-18+850 and Km: 19+280-28+280 route soil levelling artifacts, superstructure, bridge constr . BSK**

Tender Reg.No : **2017/53465**
 Bid Deadline : 14.03.2017
 Approx. Cost : 134.440.843,81 TL
 Limit value : 83.495.826,13 TL
 Winner : **TURYOL İNŞ A.Ş. EK-PET İNŞ**
 Contract Cost : 83.516.772,00 TL

- STATE HIGHWAYS ADMIN. (KGM)-14. BÖLGE MÜDÜRLÜĞÜ:** (Biga-Lapseki) junc.-Karabiga Km: 0+000-19+580 route soil levelling artifacts, superstructure constr..

Bid Method : Open
Tender Reg.No : **2017/92754**
Bid Deadline : 30.03.2017
Approx. Cost :37.205.184,80 TL
Limit value : 26.241.997,22 TL
Winner : **EZOTAŞ MAD. İNŞ LTD.**
Contract Cost : 26.289.099,94 TL
- MEAT AND MILK INSTITUTION - TEKNİK İŞLER DAİRE BAŞKANLIĞI-ANKARA:** Van new meat complex

Tender Reg.No : **2017/104693**
Bid Deadline : 31.03.2017
Approx. Cost :38.908.897,19 TL
Limit value : 27.148.559,64 TL
Winner : **GÖKÇENAY İNŞAAT A.Ş.**
DİRENÇ ALTYAPI LTD.
Contract Cost : 27.350.000,00TL
- MANİSA M.MUNICIPALITY -FEN İŞLERİ DAİRESİ BAŞKANLIĞI:** Bridged junction (Turgutlu Stage)

Tender Reg.No : **2017/88404**
Bid Deadline : 07.04.2017
Approx. Cost : 89.258.522,00 TL
Limit value : 53.531.970,94 TL
Winner : **MAPEK İNŞAAT A.Ş.**
HÜSAMETTİN PEKER LTD.
Contract Cost : 52.840.844,68 TL
- JUSTICE MINISTRY -TEKNİK İŞLER DAİRE BAŞKANLIĞI:** Erzincan penitentiary house constr

Bid Method : Auction
Tender Reg.No : **2017/149432**
Bid Deadline : 06.04.2017
Approx. Cost : 298.437.558,35 TL
Winner : **REC ULUSL. İNŞ YATIRIM SANAYİ VE TİC.A.Ş. TESAN İNŞAAT A.Ş.**
Contract Cost : 266.609.000,00 TL
- STATE HIGHWAYS ADMIN. (KGM)-14. BÖLGE MÜDÜRLÜĞÜ:** Bursa-Uludağ route soil levelling artifacts, superstructure bitumenous hot mixing

Tender Reg.No : **2017/110545**
Bid Deadline : 11.04.2017
Approx. Cost : 31.880.853,40 TL
Limit value : 26.042.195,89 TL
Winner : **ÖZTİMUR MÜT. İNŞ MAD A.Ş.**
Contract Cost : 27.000.040,00 TL
- STATE HYDRAULIC WORKS- (DSİ):** Mersin Pamuluk Dam drinking water main lines

Tender Reg.No : **2016/255184**
Bid Deadline : 12.04.2017
Approx. Cost : 129.040.539,53 TL
Limit value : 107.509.000,00 TL
Winner : **ZİVER İNŞ A.Ş.**
Contract Cost : 123.456.789,00 TL
- STATE HIGHWAYS ADMIN. (KGM)-3. BÖLGE MÜDÜRLÜĞÜ:** (Konya-Karaman) Junc.-Belören-Hadim Devlet road Km:59+800-63+580 route Eviste viaduct entry open-close structure and connection roads

Tender Reg.No : **2017/99282**
Bid Deadline : 10.04.2017
Approx. Cost : 77.728.393,80 TL
Limit value : 62.043.454,68 TL
Winner : **ZİVER İNŞ A.Ş.**
Contract Cost : 69.876.543,00 TL
- STATE HIGHWAYS ADMIN. (KGM)-. PROGRAM VE İZLEME DAİRESİ BAŞKANLIĞI:** Yeşilyurt junc.-Buldan-(Aydın-Denizli) junc road Km: 38+000-101+500 and junc Buldan road Km: 0+000-3+000 sections.

Bid Method : Open
Tender Reg.No : **2016/545399**
Bid Deadline : 12.04.2017
Approx. Cost : 165.311.201,11 TL
Limit value : 102.769.386,07 TL
Winner : **EKSEN PROJE A.Ş., GÜLERMAK A.Ş.**
Contract Cost : 102.777.412,23 TL
- STATE HIGHWAYS ADMIN. (KGM)-6. BÖLGE MÜD.:** Kayseri-Kırşehir state road Km: 104+400-119+900 route soil levelling artifacts, superstructure bitumenous hot mixing

Bid Method : Open
Tender Reg.No : **2017/106700**
Bid Deadline : 12.04.2017
Approx. Cost : 66.881.327,80 TL
Limit value : 48.697.652,48 TL
Winner : **DEHA ALTYAPI A.Ş- EREZ İNŞAAT A.Ş.**
Contract Cost : 48.713.313,00 TL
- STATE HIGHWAYS ADMIN. (KGM)-5. BÖLGE MÜDÜRLÜĞÜ:** Erdemli-Güzeloluk prov. road Km:0+000-31+437 route soil levelling artifacts, superstructure bridge const. BSK

Bid Method : Open
Tender Reg.No : **2017/102745**
Bid Deadline : 12.04.2017
Approx. Cost : 69.961.078,00 TL
Limit value : 44.461.137,10 TL
Winner : **Hİ-KA NAKLIYE İNŞAAT LTD.-, ER-DEN YOL İNŞAAT A.Ş.**
Contract Cost : 44.488.360,00 TL
- STATE HIGHWAYS ADMIN. (KGM)-15. BÖLGE MÜD.:**Kastamonu-Araç road Km:5+060-42+060 route completion

Bid Method : Open
Tender Reg.No : **2017/113297**
Bid Deadline : 11.04.2017
Approx. Cost : 230.887.502,60 TL
Limit value : 169.177.328,06 TL
Winner : **YEDİGÖZE İNŞ LTD.**
Contract Cost : 172.664.559,80 TL
- STATE HIGHWAYS ADMIN. (KGM)-14. BÖLGE MÜDÜRLÜĞÜ (BURSA):**(Balıkesir-Simav) Junc.-Sındırgı-2 Regional border road (Sındırgı peripheral road incl.) Km: 1+700-10+980 route soil levelling artifacts, superstructure bitumenous hot mixing

Bid Method : Open
Tender Reg.No : **2017/119752**
Bid Deadline : 18.04.2017
Approx. Cost : 48.610.665,70 TL
Limit value : 31.557.046,83 TL
Winner : **GÜN AL MAD. İNŞ A.Ş.**
Contract Cost : 31.598.737,00 TL
- STATE HIGHWAYS ADMIN. (KGM)-1. BÖLGE MÜDÜRLÜĞÜ:** Highway junc.-Çerkezköy state road route soil levelling artifacts, superstructure bitumenous hot mixing

Tender Reg.No : **2017/117685**
Bid Deadline : 19.04.2017
Approx. Cost : 39.725.538,20 TL
Limit value : 26.169.371,92 TL
Winner : **SED-YOL İNŞ A.Ş.**
Contract Cost : 26.923.016,00 TL

- **STATE HIGHWAYS ADMIN. (KGM)- PROGRAM VE İZLEME DAİRESİ BAŞKANLIĞI-ANKARA:** (Malatya-Darende) junc.-Gölbaşı-5. Bl. Hd. road (1. Kısım) Km: 3+500-72+000 section (Doğanşehir connect. road Km:0+000-9+000 incl.) route soil levelling artifacts, superstructure bitumenous hot mixing
Tender Reg.No :2016/455492
Bid Deadline : 17.04.2017
Approx. Cost : 218.163.279,57 TL
Limit value : 171.054.864,90 TL
Winner : **EKSEN PROJE A.Ş.GÜLERMAK A.Ş.**
Contract Cost : 171.842.092,30 TL
- **STATE HIGHWAYS ADMIN. (KGM)-7. BÖLGE MÜDÜRLÜĞÜ (SAMSUN):**(Sungurlu-Çorum) junc - Boğazkale junc.-Alaca-Çekerek-Zile-Turhal state road 6bl Hd-Turhal route (Km:0+000-57+85470) route soil levelling artifacts, superstructure bitumenous hot mixing
Tender Reg.No :2017/96895
Bid Deadline : 18.04.2017
Approx. Cost : 378.771.325,35 TL
Limit value : 233.496.043,34 TL
Winner : **İNTAŞ TAAHHÜT YAPI SAN.**
Contract Cost : 233.770.930,00 TL
- **STATE HIGHWAYS ADMIN. (KGM)-. PROGRAM VE İZLEME DAİRESİ BAŞKANLIĞI-ANKARA:** Gaziantep-Nizip-Birecik road (Nizip crossing incl.) Km:7+560-55+800 route and Km:55+800-57+440 (Birecik crossing) route soil levelling artifacts, superstructure bitumenous hot mixing
Tender Reg.No :2017/117844
Bid Deadline : 20.04.2017
Approx. Cost : 215.213.348,01 TL
Limit value : 134.183.818,68 TL
Winner : **AVOS GRUP İNŞAAT A.Ş.**
Contract Cost : 134.211.494,50 TL
- **STATE HIGHWAYS ADMIN. (KGM)-3.BÖLGE MÜDÜRLÜĞÜ (KONYA):** Karaman 5.Regional border state road Sertavul tunnel and connect. road soil levelling artifacts, superstructure bitumenous hot mixing
Tender Reg.No :2016/567900
Bid Deadline : 14.04.2017
Approx. Cost : 315.491.167,10 TL
Limit value : 251.323.892,00 TL
Winner : **ASTRO ÜST YAPI A.Ş. TARMAC AGREGA MAD.AŞ**
Contract Cost : 252.370.693,64 TL
- **STATE HIGHWAYS ADMIN. (KGM)- Program ve İzleme Dairesi Başkanlığı:** Nevşehir-Ürgüp (Avanos-Kayseri junc.) Km: 4+500-27+139,76 and Nevşehir-Avanos (Kayseri-Niğde junc) Km: 22+644,67-52+186,97 sections constr.
Tender Reg.No :2016/459480
Bid Deadline : 19.04.2017
Approx. Cost : 161.617.874,88 TL
Limit value : 103.333.466,07 TL
Winner : **BUDAKYOL İNŞ. A.Ş. HAZARYOL İNŞAAT A.Ş.**
Contract Cost : 103.385.652,90 TL
- **STATE AIRPORTS MANAGEMENT-DHM:**Milas Bodrum Airport PAT areas repair
Tender Reg.No :2017/102241
Bid Deadline : 19.04.2017
Approx. Cost : 119.757.760,15 TL
Limit value : 81.657.814,96 TL
Winner : **KISKA-KOM A.Ş. GENA İNŞAAT A.Ş.**
Contract Cost : 81.673.000,00 TL
- **STATE HIGHWAYS ADMIN. (KGM)-12. BÖLGE MÜDÜRLÜĞÜ:** Erzurum-Tortum state road Km:0+000-46+120 route soil levelling artifacts, superstructure bitumenous hot mixing BSK
Bid Method : Open
Tender Reg.No : 2017/126086
Bid Deadline : 26.04.2017
Approx. Cost : 112.892.127,60 TL
Limit value : 88.504.417,54 TL
Winner : **NESCE İNŞAAT ENERJİVE TİCARET A.Ş.**
Contract Cost : 89.918.880,00 TL
- **STATE HIGHWAYS ADMIN. (KGM)-14.BÖLGE MÜDÜRLÜĞÜ (BURSA):** (Bursa-Orhaneli) junc.-Keles-Tavşanlı junc Km:0+000-41+745,27 road soil levelling artifacts, superstructure bitumenous hot mixing
Bid Method : Open
Tender Reg.No : 2017/123304
Bid Deadline : 25.04.2017-10.00
Approx. Cost : 45.240.961,60 TL
Limit value : 30.201.406,28 TL
Winner : **ÖZCE İNŞAAT LTD.ŞTİ.**
Contract Cost : 30.277.012,00 TL
- **STATE HIGHWAYS ADMIN. (KGM)- PROGRAM VE İZLEME DAİRESİ BAŞKANLIĞI:** Zonguldak-Amasra-Kurucasıle (Çakraz-Kurucasıle route) road Km: 37+061,95-46+400 road soil levelling artifacts, superstructure bitumenous hot mixing
Bid Method : Auction
Tender Reg.No : 2017/193913
Bid Deadline : 25.04.2017
Approx. Cost : 1.061.595.706,67 TL
Winner : **YSE YAPI SANAYİ VE TİCARET**
Contract Cost : 795.056.660,70 TL
- **STATE HIGHWAYS ADMIN. (KGM)-14. BÖLGE MÜDÜRLÜĞÜ:** (Bandırma-Biça) junc - Erdek İ1 road Km:0+000- 15+000 road soil levelling artifacts, superstructure bitumenous hot mixing
Bid Method : Açık
Tender Reg.No :2017/122353
Bid Deadline : 27.04.2017
Approx. Cost : 44.575.223,30 TL
Limit value : 31.214.524,29 TL
Winner : **MAU YAPI İNŞAAT A.Ş. MEHMET ALİ ÜNAL İNŞAAT A.Ş.**
Contract Cost : 31.971.107,60 TL
- **STATE HIGHWAYS ADMIN. (KGM)-4.BÖLGE MÜDÜRLÜĞÜ-ANKARA:** Anadolu Highway Gerede Junc.-KGM 1. Bölge Müd. Border route soil levelling artifacts, superstructure, connect. roads repair, bitumenous hot mixing
Bid Method : Open
Tender Reg.No :2017/150411
Bid Deadline : 04.05.2017
Approx. Cost : 46.382.345,26 TL
Limit value : 37.694.814,09 TL
Winner : **ONUR TAAH A.Ş.**
Contract Cost : 38.105.070,00 TL
- **STATE HIGHWAYS ADMIN. (KGM)-14.BÖLGE MÜDÜRLÜĞÜ- (BURSA)** Gölpaazarı-Yenipazar road Km: 0+000 - 27+420 road soil levelling artifacts, superstructure bridge constr.
Tender Reg.No :2017/155732
Bid Deadline : 04.05.2017
Approx. Cost : 57.556.583,07 TL
Limit value : 39.690.345,50 TL
Winner : **GÜR ÇELİK İNŞ. A.Ş.**
Contract Cost : 40.287.665,00TL

- **STATE HIGHWAYS ADMIN. (KGM)-GENEL MÜDÜRLÜĞÜ:** Sabuncubeli Tunnel and connection road (second. works included) (compl.) Km:0+000-6+390,02 road soil levelling artifacts, superstructure bitumenous hot mixing

Bid Method : Auction
Tender Reg.No : **2017/195520**
Bid Deadline : 28.04.2017
Approx. Cost : 225.794.625,56 TL
Winner : **MAKYOL İNŞAAT A.Ş.**
Contract Cost : 189.015.332,84 TL
- **STATE HIGHWAYS ADMIN. (KGM)-ANKARA:** Van-Muradiye state road (Km:20+100-68+000) road soil levelling artifacts, superstructure bitumenous hot mixing (BSK) : 49 firms contested.

Bid Method : Open
Tender Reg.No : **2017/143884**
Bid Deadline : 03.05.2017
Approx. Cost : 175.220.995,34 TL
Limit value : 108.642.465,51 TL
Winner : **NEHİRSU İNŞAAT A.Ş. İMAJ ALTYAPI ÜST YAPI A.Ş.**
Contract Cost : 108.668.582,50 TL
- **MINISTRY OF TRANSPORT AND MARITIME.:** Yalova-Amutlu Kapaklı Fisherman's shelter constr.

Bid Method : Open
Tender Reg.No : **2017/125766**
Bid Deadline : 27.04.2017
Approx. Cost : 46.025.105,89 TL
Limit value : 36.414.563,89 TL
Winner : **3 EL GRUP ENERJİ MAD. İNŞ.**
Contract Cost : 39.312.000,00 TL
- **STATE HIGHWAYS ADMIN. (KGM)-13.BÖLGE MÜD. (ANTALYA):** Eğirdir-Gelendost-Sarkikaraağaç-3BlHd road (Km:58+300-73+300 route) road soil levelling artifacts, superstructure bitumenous hot mixing and BSK

Bid Method : Open
Tender Reg.No : **2017/125325**
Bid Deadline : 02.05.2017
Approx. Cost : 99.740.490,40 TL
Limit value : 76.265.977,57 TL
Winner : **AYDIN İNŞ. A.Ş. IRMAKYOL**
Contract Cost : 80.899.992,65 TL
- **STATE HYDRAULIC WORKS- (DSİ):** Kahramanmaraş Afşin drinking water main lines (75 km and other civil works.)

Bid Method : Open
Tender Reg.No : **2017/150217**
Bid Deadline : 05.05.2017
Approx. Cost : 99.531.282,43 TL
Limit value : 76.861.867,26 TL
Winner : **SAMSUN MAKİNA SANAYİ A.Ş.**
Contract Cost : 81.743.673,11 TL
- **STATE HIGHWAYS ADMIN. (KGM)-15. BÖLGE MÜDÜRLÜĞÜ (KASTAMONU)** Alaplı-Yığılca road Km:0+000-20+600,road soil levelling artifacts, superstructure bitumenous hot mixing, bridge (PMAT, PMT, BSK).

Tender Reg.No : **2017/165947**
Bid Deadline : 10.05.2017
Approx. Cost : 114.244.012,09 TL
Limit value : 71.292.823,86 TL
Winner : **BİMHOLL İNŞ A.Ş. DİDO-RAY YAPI A.Ş**
Contract Cost : 71.877.935,94 TL
- **STATE HIGHWAYS ADMIN. (KGM)-14. BÖLGE MÜDÜRLÜĞÜ:** İznik-Mekece State road Km: 0+000-28+315 (compl.) and İznik peripheral road Km: 0+000-7+250 road soil levelling artifacts, superstructure bitumenous hot mixing (BSK)

Tender Reg.No : **2017/159917**
Bid Deadline : 10.05.2017
Approx. Cost : 139.074.829,59 TL
Limit value : 90.998.041,70 TL
Winner : **DANIŞ YAPI A.Ş, ÖZTİMUR MÜT. A.Ş.**
Contract Cost : 91.100.143,52 TL
- **STATE HIGHWAYS ADMIN. (KGM)-3. BÖLGE MÜDÜRLÜĞÜ:** (Belören-Hadim) Junc.-Karaman road Km:0+000-7+300 and Km:20+100-29+804 road soil levelling artifacts, superstructure bitumenous hot mixing

Tender Reg.No : **2017/163314**
Bid Deadline : 09.05.2017
Approx. Cost : 35.593.063,86 TL
Limit value : 22.002.301,79 TL
Winner : **AKH MAD. A.Ş. AKHEL İNŞ**
Contract Cost : 22.222.222,00 TL
- **STATE HIGHWAYS ADMIN. (KGM)-1. BÖLGE MÜDÜRLÜĞÜ (İSTANBUL):** Kaynarca-Karasu-Kocaali-4 Regional border road soil levelling artifacts, superstructure bitumenous hot mixing, bridge, tunnel constr.(25 km)

Bid Method : Preselection
Tender Reg.No : **2016/547105**
Başvuru Tarihi : 30.12.2016
Bid Deadline : 15.05.2017-14.00
Approx. Cost : 443.279.944,82 TL
Limit value : 336.802.652,85 TL
Winner : **DOĞUŞ İNŞAAT VE TİCARET**
Contract Cost : 370.946.584,04TL
- **STATE HIGHWAYS ADMIN. (KGM)-10. BÖLGE MÜDÜRLÜĞÜ-TRABZON:** Black Sea coastal road Espiye Çarşıbaşı route (Vakıfkebir crossing) Km: 0+000-5+400,56 road soil levelling artifacts, superstructure bitumenous hot mixing (Bsk)

Tender Reg.No : **2017/193601**
Bid Deadline : 16.05.2017-10.00
Approx. Cost : 34.363.989,00 TL
Limit value : 22.618.202,48 TL
Winner : **UDÇ İNŞ TAAHHÜT A.Ş.**
Contract Cost : 22.733.438,00 TL
- **STATE HIGHWAYS ADMIN. (KGM)-1.BÖLGE MÜDÜRLÜĞÜ (İSTANBUL):** Kınalı Junc.-Çorlu state road soil levelling artifacts, superstructure bitumenous mixing

Tender Reg.No : **2017/150312**
Bid Deadline : 16.05.2017-10.00
Approx. Cost : 170.213.751,52 TL
Limit value : 106.499.811,78 TL
Winner : **EMİROĞLU İNŞ. LTD.ŞTİ.**
Contract Cost : 106.550.126,00 TL
- **STATE HIGHWAYS ADMIN. (KGM) Ahlat-Adilcevaz State road and Adilcevaz-Erciş State road road soil levelling artifacts, superstructure bitumenous hot mixing (BSK)**

Tender Reg.No : **2017/178016**
Bid Deadline : 23.05.2017
Approx. Cost : 152.415.875,36 TL
Limit value : 98.288.145,66 TL
Winner : **İNTAŞ TAAHHÜT TİC.A. Ş.**
Contract Cost : 99.799.769,00 TL

- **STATE HIGHWAYS ADMIN. (KGM)-8. BÖLGE MÜDÜRLÜĞÜ (ELAZIĞ)** Pütürge Junc.-Doğanıyol road Km: 0+000-24+37832 road soil levelling artifacts, superstructure bitumenous hot mixing (3 ea soil levelling, .17 ea artifacts .3 ea superstructure)
Tender Reg.No : 2017/175881
Bid Deadline : 23.05.2017
Approx. Cost : 70.355.288,44 TL
Limit value : 43.943.446,42 TL
Winner : **EZEKAR YAPI , GENÇBAY İNŞ**
Contract Cost : 41.649.998,00 TL
- **STATE HIGHWAYS ADMIN. (KGM)- Program ve İzleme Dairesi Başkanlığı: Canakkale Ayvacık – Küçükkuyu road Ezine-Küçükkuyu route Km550-05 Km: 31+000-43+000 road soil levelling artifacts, superstructure bitumenous hot mixing**
Tender Reg.No : 2017/247261
Bid Deadline : 30.05.2017
Approx. Cost : 1.207.652.114,36 TL
Limit value : 887.835.576,65 TL
Winner : **KOLİN İNŞAAT. -KALYON İNŞ**
Contract Cost : 904.965.270,59 TL
- **STATE HIGHWAYS ADMIN. (KGM)-7. BÖLGE MÜDÜRLÜĞÜ:** KKNö (60-04) Niksar-Başçiftlik-(Aybastı-Reşadiye) junc. road Km:0+000-13+500 and 23+000-38+607.695 road soil levelling artifacts, superstructure
Tender Reg.No : 2017/205826
Bid Deadline : 01.06.2017
Approx. Cost : 73.514.311,82 TL
Limit value : 46.146.505,54 TL
Winner : **DNZ İNŞAAT A.Ş.**
Contract Cost : 46.144.150,00 TL
- **STATE HIGHWAYS ADMIN. (KGM)-17. BÖLGE MÜDÜRLÜĞÜ:** Boyabat crossing road soil levelling artifacts, superstructure bitumenous hot mixing bsk
Tender Reg.No : 2017/200205
Bid Deadline : 31.05.2017
Approx. Cost : 127.689.932,89 TL
Limit value : 81.106.374,01 TL
Winner : **AYDIN İNŞ. , IRMAKYOL İNŞ**
Contract Cost : 80.857.650,00 TL
- **STATE HIGHWAYS ADMIN. (KGM)-14. BÖLGE MÜDÜRLÜĞÜ:** Bigadic-Simav-Abide road Demirci Junc.-(Uşak-Kütahya) junc. route km: 114+700-129+685 road soil levelling artifacts, superstructure bitumenous mixing
Tender Reg.No : 2017/199838
Bid Deadline : 30.05.2017
Approx. Cost : 167.160.011,64 TL
Winner : **YEDİGÖZE İNŞ LTD**
Contract Cost : 132.794.150,00 TL
- **STATE HIGHWAYS ADMIN. (KGM)-:Dursunbey-Harmançık-Taşanlı road Km: 5+500-29+030, 42G/29+039,66l-44+783,65G/136+652l-187+620road soil levelling artifacts, superstructure bitumen. mixing.**
Tender Reg.No : 2016/581873
Bid Deadline : 06.06.2017
Approx. Cost : 190.570.310,98 TL
Winner : **FARSEL İNŞ A.Ş. KAYAOĞLU**
Contract Cost : 157.800.398,13 TL
- **STATE HIGHWAYS ADMIN. (KGM)-18.BÖLGE MÜDÜRLÜĞÜ (KARS):** KK No 36-31 Diğor-Esenkent road soil levelling artifacts, superstructure
Bid Method : Open
Tender Reg.No : 2017/243914
Bid Deadline : 13.06.2017
Approx. Cost : 28.012.177,40 TL
Limit value : 22.440.983,69 TL
Winner : **MİLA ENERJİ, ÖRENSAN İNŞ**
Contract Cost : 21.249.400,00 TL
- **STATE HIGHWAYS ADMIN. (KGM)- PROGRAM VE İZLEME DAİRESİ BAŞKANLIĞI: Van-Tatvan road Km: 11+000-58+500 section**
Bid Method : Open
Tender Reg.No : 2017/5670
Bid Deadline : 19.06.2017
Approx. Cost : 158.401.251,83 TL
Limit value : 101.709.314,51 TL
Winner : **EZEKAR YAPI A.Ş.İNTAŞ TAAH A.Ş. CNG YAPI A.Ş.**
Contract Cost : 102.102.102,00 TL
- **STATE HIGHWAYS ADMIN. (KGM)- PROGRAM VE İZLEME DAİRESİ BAŞKANLIĞI** Kastamonu-İnebolu road Km:34+700-41+702,537g / 47+554,83i-79+300 soil levelling artifacts, superstructure bitumen. works.
Bid Method : Preselection
Tender Reg.No : 2017/147184
Date for Applic. : 18.04.2017
Bid deadline : 18.07.2017 10.00
Approx. Cost : 1.737.362.201,84 TL
Winner : **CENGİZ İNŞ A.Ş. ÖZALTIN İNŞ**
Contract Cost : 1.389.889.728,41 TL
- **STATE HIGHWAYS ADMIN. (KGM)-:Bahşili-Karakeçili-Kulu junc. Km: 0+000-29+708 Km: 0+000-55+127 road soil levelling artifacts, superstructure bitumen. mixing.**
Bid Method : Preselection
Tender Reg.No : 2017/175638
Date for Applic. : 04.05.2017
Bid Deadline : 26.07.2017 10.00
Approx. Cost : 214.337.275,92 TL
Limit value : 138.004.317,81 TL
Winner : **İMAJ ALTYAPI A.Ş. BÜYÜK ZİGANA A.Ş.**
Contract Cost : 138.109.208,55 TL
- **STATE HIGHWAYS ADMIN. (KGM)- PROGRAM VE İZLEME DAİRESİ BAŞKANLIĞI:** Gölbasi - Adıyaman - Kahta road Km: 0+000 - 44+500, Km:59+000 - 98+000 road soil levelling artifacts superstructure bitumen.mixing.
Tender Reg.No : 2016/580690
Bid Deadline : 20.07.2017
Approx. Cost : 202.737.157,98 TL
Limit value : 135.519.784,03 TL
Winner : **GÜRŞAH HAF. İNŞ. LTD-HAZARYOL İNŞ. A.Ş.-BUDAKYOL A.Ş.**
Contract Cost : 136.345.223,50 TL
- **STATE HYDRAULIC WORKS- PROJE VE İNŞAAT DAİRESİ BAŞKANLIĞI:** Kralkızı-Dicle P-3 pumping irrigation supply lines, pump. Station and trunk main.
Tender Reg.No : 2017/209944
Bid Deadline : 27.07.2017
Approx. Cost : 329.471.634,72 TL
Limit value : 248.718.889,83 TL
Winner : **CEYLAN İNŞ A.Ş.**
Contract Cost : 268.459.076,40 TL
- **STATE HIGHWAYS ADMIN. (KGM)-10. BÖLGE MÜDÜRLÜĞÜ:** Of-Çaykara (Dokap) road Km: 10+990 - 25+972 road soil levelling artifacts, superstructure bitumenous mixing, tunnel, (Bsk)
Tender Reg.No : 2017/208302
Bid Deadline : 17.08.2017
Approx. Cost : 388.152.561,53 TL
Limit value : 298.960.072,84 TL
Winner : **YEDİGÖZE İNŞ -ÖRNEK İNŞ . - ÖZGÜR SARIALIOĞLU-DİLER SARIALIOĞLU**
Contract Cost : 309.800.416,90 TL

- **STATE HIGHWAYS ADMIN. (KGM)- PROGRAM VE İZLEME DAİRESİ BAŞKANLIĞI:** Konya peripheral road (KOP) KM: 109+000 - 128+247 (G) / 0+000 (İ) - 26+900 road soil levelling artifacts, superstructure bitumenous hot mixing
 Bid Method : Open
 Tender Reg.No : **2016/580742**
 Bid Deadline : 22.08.2017
 Approx. Cost : 354.315.181,54 TL
 Limit value : 277.081.297,09 TL
 Winner : **SEZA İNŞ LTD.ŞTİ, AÇILIM İNŞ LTD.**
 Contract Cost : 293.270.833,00 TL
- **STATE HIGHWAYS ADMIN. (KGM)-1. BÖLGE MÜDÜRLÜĞÜ:** Topca layered junc. road soil levelling artifacts, superstructure bitumenous mixing bridge.etc.
 Bid Method : Open
 Tender Reg.No : **2016/354724**
 Bid Deadline : 22.08.2017
 Approx. Cost : 58.588.761,07 TL
 Limit value : 39.665.651,15 TL
 Winner : **ABAT YOL İNŞ A.Ş. ENSAR İNŞ**
 Contract Cost : 293.270.833,00 TL
- **STATE HIGHWAYS ADMIN.:** (Bursa - İnegöl) Junc. - Yenisehir - (Bilecik - Osmaniye) junc. road Km: 25+000 - 65+314.50 and Yenisehir South crossing Km: 0+000 - 7+419.06 sections
 Tender reg.no : **2017/113977**
 Bid deadline : 21.10.2014
 Winner : **EMİROĞLU İNŞAAT**
 Approx. cost : 211.067.768,31 TL
 Contract cost : 107.367.506,65 TL
- **KGM 8.BÖLGE MÜDÜRLÜĞÜ (ELAZIĞ):** (Çemişgezek-Ferry berth) junc.- (Hozat - Pertek) Junc. road Km : 0+000 - 23+727 route
 Tender reg.no : **2017/402562**
 Bid deadline : 21.08.2017
 Winner : **FİMAŞ YAPI A.Ş**
 Approx. cost : 125.422.899,17 TL
 Contract cost : 109.028.918,70 TL
- **STATE RAILWAYS ADMIN. (TCDD):** 2 Bölge Müdürlüğü: Irmak-Zonguldak lines Irmak-Tüney and Çankırı-Kurşunlu stations route 123,8 km road renewal
 Tender reg.no : **2017/562447**
 Bid deadline : 16.11.2017
 Winner : **YAPIRAY DEMİRYOLU İNŞ.**
 Approx. cost : 101.318.191,62 TL
 Contract cost : 93.799.998,61 TL
- **STATE RAILWAYS ADMIN.-TCDD İŞLETMESİ GENEL MÜDÜRLÜĞÜ:** Sivas-Erzincan railway project infrastructures.
 Tender Reg.No : **2016/465065**
 Bid Deadline : 22.08.2017
 Approx. Cost : 960.367.288,88 TL
 Winner : **ÖZKAR İNŞAAT+ÖZALTIN İNŞ**
 Contract Cost : 918.207.648,65 TL
- **DSİ 8.BÖLGE MÜDÜRLÜĞÜ (ERZURUM):** Erzincan Merkez Vasqirt and Hançerli streams rehabilitations 1.Stage
 Bid method : Open
 Tender reg.no : **2017/320807**
 Bid deadline : 25.07.2017
- Winner : **ÖZBEK İNŞ.+MUZAFFER KAYGIN İNŞ.**
 Approx. Cost : 28.002.394,60 TL
 Contract cost : 19.662.000,00 TL
- **STATE HIGHWAYS- 10.BÖLGE MÜDÜRLÜĞÜ (TRABZON):** -Konaklar-Pelitli-Yalıncak (Black sea coastal road link) (DOKAP) road, Black sea coastal road link , Kaşüstü junc. underpass bridge (Km: 60+829745 - 62+025019) route soil levelling artifacts bridge, BSK works
 Bid method : Auction (MD 21 B)
 Tender reg.no : **2017/619737**
 Bid deadline : 30.11.2017
 Winner : **SANCAR İNŞ.+MAK İŞ İNŞ.**
 Approx. Cost : 159.883.236,62 TL
 Contract cost : 117.897.885,00 TL
- **STATE HIGHWAYS - 10.BÖLGE MÜDÜRLÜĞÜ (TRABZON):** (Borçka-Artvin) Junc. -Murgul-Damar (DOKAP) road, Murgul-Damar Km:0+000-11+215,47 route soil levelling artifacts .
 Tender reg.no : **2017/210929**
 Bid deadline : 26.05.2017
 Winner : **SAĞLAMLAR İNŞ A.Ş**
 Approx. Cost : 35.952.470,88 TL
 Contract cost : 22.363.710,00 TL
- **KGM 8.BÖLGE MÜDÜRLÜĞÜ (ELAZIĞ):** :"Mal-Hek-16blhd road Sarsap tunnel, Karakısık 1 tunnel,Karakısık 2 tunnel,Hasançelebitün T1 tunnel,T2 tunnel,T3 tunnel secnodary works (ventil. İllum. Commun. Fire alarm, SCADA, control sys.elect. electronic works)
 Tender reg.no : **2017/145301**
 Bid deadline : 10.05.2017
 Winner : **SAVRONİK ELEKTRONİK**
 Approx. cost : 48.786.837,88 TL
 Contract cost : 26.470.000,00 TL
- **KGM 8.BÖLGE MÜDÜRLÜĞÜ (ELAZIĞ):** Roads flood damages rehabilitation , artifacts superstructure repairs
 Tender reg.no : **2017/264204**
 Bid deadline : 24.07.2017
 Winner : **MURAT DEMİRCİ İNŞAAT**
 Approx. cost : 19.712.452,14 TL
 Contract cost : 12.391.635,20 TL
- **KGM 10.BÖLGE MÜDÜRLÜĞÜ (TRABZON):** (Arsin-Araklı)Junc. -Atayurt Km: 0+000 - 20+919,80 route soil levelling artifacts bridge, tunnel and superstructure (BSK) etc.
 Bid method : Open
 Tender reg.no : **2017/352971**
 Bid deadline : 21.08.2017
 Winner : **ESKİKALE İNŞ.+GLS İNŞ. AYDIN İNŞ.+ÜNAL AKPINAR İNŞ.**
 Approx. cost : 124.397.391,17 TL
 Contract cost : 84.862.044,10 TL
- **HEALTH INVESTMENTS GEN. DIRECT.:** Sivas Numune Hospital 250 –bed annex building and admin. facilities
 Bid method : Open
 Tender reg.no : **2017/449476**
 Bid deadline : 26.10.2017
 Winner : **ZEY YAPI+PEKHAN İNŞ.**
 Approx. cost : 132.678.218,63 TL
 Contract cost : 106.675.000,00 TL

474 FAIR ORGANIZATIONS ARE SCHEDULED TO TAKE PLACE IN 2018

The Turkish Union of Chambers and Commodity Exchange (TOBB) has allowed 474 fair organizations nationwide in 2018. Below are these fairs and dates of organization for your interest:

START	FINISH	FAIR NAME	MAIN PRODUCTS / SERVICE GROUPS	LOCATION	CITY	ORGANIZED BY:
12.04.2018	15.04.2018	Mersin Building Fair	Construction, Building materials, technologies and decoration	Yenişehir Fuar Merkezi	Mersin	Pozitif Fuarçılık A.Ş.
19.04.2018	21.04.2018	5th Geothermal Energy Technologies and Equipments	Geothermal Energy Technologies and Equipments	Tepekule Kongre ve Sergi Merkezi	İzmir	Demos Fuarçılık ve Org. A.Ş.
19.04.2018	21.04.2018	BUSWORLD TURKEY 2018	Bus And Coach Builders, Mini Buses, Spare Parts, Accessories, Equipment	Fuar İzmir - Gazimur	İzmir	HKF Fuarçılık A.Ş.
19.04.2018	22.04.2018	Expomen S.O.S First Aid, Fire, Disaster, Occupational Health and Safety	First Aid, Fire, Disaster, Occupational Health and Safety	Menemen Fuar Alanı	İzmir	Elit Fuarçılık Hizmetleri Ltd.Şti.
19.04.2018	22.04.2018	Expomen Municipal Equipment, Urban and Public Procurement Fair	Municipal Equipment, Urban and Public Utilities and Technologies	Menemen Fuar Alanı	İzmir	Elit Fuarçılık Hizmetleri Ltd.Şti.
19.04.2018	22.04.2018	Konya 15th. Construction Fair	Construction materials, technologies, natural gas, heating, cooling, air conditioning	KTO Tüyap Konya Uluslararası Fuar Merkezi	Konya	Tüyap Konya Fuarçılık A.Ş.
19.04.2018	22.04.2018	Konya Urban 2018 - 14. Municipal Necessities, Urban Furnishing, Landscaping, Fire Engines and Fire Safety Fair	Municipal Necessities, Urban Furnishing, Landscaping, Fire Engines and Safety	KTO Tüyap Konya Uluslararası Fuar Merkezi	Konya	Tüyap Konya Fuarçılık A.Ş.
24.04.2018	29.04.2018	Çukurova 6th Autoshow 2018	Automobile, commercial vehicles, motorcycle, bicycle	Tüyap Adana Uluslararası Fuar ve Kongre Merkezi	Adana	Tüyap Adana Fuarçılık A.Ş.
25.04.2018	26.04.2018	6th International İstanbul Smart Grid and Cities, energy, IT, Congress and Fair (ICSG İSTANBUL 2018)	Smart Grid and Cities, energy, IT, Smart Meters,	İstanbul Kongre Merkezi	İstanbul	HHB Fuar Organizasyon Reklam A.Ş.
25.04.2018	28.04.2018	Concrete İzmir 2018	10th Ready Concrete, Cement, and Aggregate Producers, Transmixers, Excavators, Pumps, Scaffolding Systems, Sand and Gravel Industries, Chemicals, Testing Systems	Fuar İzmir - Gazimur	İzmir	Kalite Fuar Yapım A.Ş.
25.04.2018	29.04.2018	EURASIA AIRSHOW	Aerospace Technologies, Products and Aerobatic Displays	Antalya Uluslararası Havaalanı	Antalya	MC Fuarçılık Ltd.Şti.
25.04.2018	29.04.2018	8th Thrace Autoshow	Automobile, Commercial Vehicles, Motorcycle, Bicycle And Accessories, Modified Tools and Accessories	Lüleburgaz Semt ve Fuar Alanı	Kırklareli	Renkli Fuarçılık Ltd. Şti.
26.04.2018	28.04.2018	Inelx 11th. Elevator And Elevator Technologies Fair	Lift Component Manufactures, Suppliers, Insallation Company, Installers, Escalator And Moving Walkways, Notified Body, Ass.	Fuar İzmir - Gazimur	İzmir	Efor Ege Fuarçılık Org. Ltd. Şti.
26.04.2018	29.04.2018	Teke Region 4th.Live Animals, livestock, Agriculture and feed technology fair	Tractors, Agriculture and Livestock Equipment, Greenhouse, feed, seed, fertilizer, pharmaceuticals, Meat and Milk Technology	Burdur Kapalı Çok Amaçlı Fuar Alanı	Burdur	GL Platform Fuarçılık Hizmetleri Ltd. Şti.

START	FINISH	FAIR NAME	MAIN PRODUCTS / SERVICE GROUPS	LOCATION	CITY	ORGANIZED BY:
02.05.2018	04.05.2018	5th Dams & H.E.S. Fair	Materials, Equipment and Project Services for Dam and Hydropower plant Construction	İstanbul Fuar Merkezi Yeşilköy	İstanbul	Demos Fuarçılık ve Org. A.Ş.
02.05.2018	04.05.2018	ICCI- International Energy And Environment Fair And Conference	Energy generation, transmission and disribution	İstanbul Fuar Merkezi Yeşilköy	İstanbul	Sektörel Fuarçılık A.Ş.
03.05.2018	06.05.2018	POLAGRI'18 3rd Polatlı Agricultural Equipment, Food and livestock fair	Agriculture and livestock equipment food	Polatlı Fuar Alanı	Ankara	Zümrüt Fuarçılık Tan. Org. San. Ve Tic. Ltd. Şti.
08.05.2018	10.05.2018	High Speed Rail Exhibition	Railway Appliances Manufacturing, Engineering Services, Design, Passenger Services, Operational Management, Technological Innovation, Financial Institutions	ATO Kongre ve Sergi Sarayı	Ankara	Alle Uluslararası Fuar Org. Hizmet. Ltd.Şti
08.05.2018	12.05.2018	ICS Istanbul Construction Show	Construction, Building Materials, Technologies, and Decoration	İstanbul Fuar Merkezi Yeşilköy	İstanbul	Pozitif Fuarçılık A.Ş.
08.05.2018	12.05.2018	41st Yapı - Turkeybuild İstanbul 2018	Services, Infrastructure, Structural System, Completion of Structure, Finishing Works, Installations, Building Equipment, Kitchen, Bathroom, Landscaping	Tüyap Fuar ve Kongre Merkezi	İstanbul	Yem Fuarçılık A.Ş.
08.05.2018	13.05.2018	Bursa 10. Otoshow Fair	Automobile,Commercial Vehicles, Accessories (Tunning Special Ses.)	Bursa Uluslararası Fuar ve Kongre Merkezi	Bursa	Tüyap Bursa Fuarçılık A.Ş.
10.05.2018	13.05.2018	Konmak 2018 Konya 15th. Metal Processing Machines, Welding, Drilling, Cutting Technologies, Materials And Hand Tools Fair	Metal Processing Machines, Welding, Drilling, Cutting Technologies, Materials And Hand Tools, Hydraulic And Pneumatic	KTO Tüyap Konya Uluslararası Fuar Merkezi	Konya	Tüyap Konya Fuarçılık A.Ş.
10.05.2018	13.05.2018	Iskon 2018 - Konya 13th Handling, Storage, Transport, Crane And Logistics Fair	Handling, Storage, Transport, Logistics, Crane	KTO Tüyap Konya Uluslararası Fuar Merkezi	Konya	Tüyap Konya Fuarçılık A.Ş.
10.05.2018	13.05.2018	Konya 4th Sheet Metal Processing Technologies Fair	Sheet metal, pipe, profile processing	KTO Tüyap Konya Uluslararası Fuar Merkezi	Konya	Tüyap Konya Fuarçılık A.Ş.
20.06.2018	25.06.2018	Yacht Show Eurasia	Boat and Boat Equipments, Brokerage, Marine Accessories	Palmarina - Bodrum	Muğla	Via Fuarçılık A.Ş.
11.07.2018	15.07.2018	Edime Food, Agriculture, Livestock Industry Fair	Tractor and farm equipment, white and brown goods, electronic equipment, Agricultural and Livestock teknoloji	Edirne Fuar Alanı	Edime	Renkli Fuarçılık Ltd. Şti.
09.08.2018	12.08.2018	Aksaray Livestock, Fertilizer, Meat and Dairy, Agriculture, Farming Machinery equipment and technologies Fair	Livestock Breeding Machines Equipments and Technologies	Ticaret Borsası Tarım Ticaret Merkezi	Aksaray	Elit Fuarçılık Hizmetleri Ltd.Şti.
06.09.2018	09.09.2018	8th Afyonkarahisar Agriculture, stockbreeding and agro technology fair (AFTAR)	Agriculture, stockbreeding, Agriculture machinery, dairy industry, packaging and fruit	Kültürpark Belediye Fuar Alanı	Afyonkarahisar	ART Fuar Org.Tic Ltd.Şti.
06.09.2018	09.09.2018	Uşak 4th Agean Region Agricultural and Livestock , dairy technology, farm equipment , green house technology	Livestock and Agricultural technology equipmnet ,tractors, greenhouse	Kemal Öz Çok Amaçlı Fuar Alanı	Uşak	GL Platform Fuarçılık Hizmetleri Ltd. Şti.
06.09.2018	09.09.2018	Agrotec 2018 22nd International Agriculture and Agriculture Technologies Fair	Agricultural Machinery & Technologies	ANFA Altınpark Fuar Merkezi	Ankara	İnfo Uluslararası Fuar Tan. Org. A.Ş.
07.09.2018	16.09.2018	87th İzmir International Fair	Health, Food, Automotive, Trade Vehicles, Construction Equipment, Machinery, Furniture, Finance, Communication, IT Technologies	Uluslararası İzmir Fuar Alanı - Kültürpark	İzmir	İZFAŞ İzmir Fuarçılık Hizmet. Kültür ve Sanat İşleri. Tic.A.Ş
12.09.2018	15.09.2018	Metalexpo Eurasia	Iron, steel, metal,machineries, parts, working technologies	İstanbul Fuar Merkezi Yeşilköy	İstanbul	Sky Fuarçılık A.Ş.

START	FINISH	FAIR NAME	MAIN PRODUCTS / SERVICE GROUPS	LOCATION	CITY	ORGANIZED BY:
12.09.2018	15.09.2018	Steel Expo	Iron, steel, metal, machineries, parts, working technologies	İstanbul Fuar Merkezi Yeşilköy	İstanbul	Sky Fuarçılık A.Ş.
13.09.2018	15.09.2018	Saha Expo	Defence	İstanbul Fuar Merkezi Yeşilköy	İstanbul	İstanbul Dünya Ticaret Merkezi A.Ş.
13.09.2018	16.09.2018	Afyonkarahisar livestock, agro, meat, and dairy technologies, machines and equipments	livestock, agro, meat, and dairy technologies, machines and equipments	Canlı Hayvan Borsası Alanı	Afyonkarahisar	Elit Fuarçılık Hizmetleri Ltd.Şti.
13.09.2018	16.09.2018	ANKA-MAK 2018 3rd Machinery and Machine Technologies Fair	Metal Processing Machinery, Hydraulic Systems, Industrial Products	ANFA Altnpark Fuar Merkezi	Ankara	İnfo Uluslararası Fuar Tan. Org. A.Ş.
20.09.2018	23.09.2018	Citytech 12th International Municipal Equipment Fair	Municipal and Environmental Equipment, Recycling Technologies	ANFA Altnpark Fuar Merkezi	Ankara	İnfo Uluslararası Fuar Tan. Org. A.Ş.
20.09.2018	23.09.2018	SU-TEK 2nd Water and Water Technologies Fair	Water Construction Elements, Dam and HES Technologies	ANFA Altnpark Fuar Merkezi	Ankara	İnfo Uluslararası Fuar Tan. Org. A.Ş.
20.09.2018	23.09.2018	CNR ENERGY İstanbul	Energy and Environment Technologies	İstanbul Fuar Merkezi Yeşilköy	İstanbul	İstanbul Fuarçılık A.Ş.
29.09.2018	07.10.2018	Eurasia Boatshow 2018 Sea Vehicles, Equipments and Accessories Exhibition	Motor Boats And Motor Yachts, Sailed Boats And Sailed Yachts, Motors And Power Equipments, Boat Accessories, Boat Construction Materials	İstanbul Fuar Merkezi Yeşilköy	İstanbul	Pozitif Fuarçılık A.Ş.
02.10.2018	07.10.2018	Konya 6th Autoshow 2018	Automobile, commercial vehicles	KTO Tüyap Konya Uluslararası Fuar Merkezi	Konya	Tüyap Konya Fuarçılık A.Ş.
02.10.2018	07.10.2018	Diyarbakır 4th Autoshow 2018	Automobile, commercial vehicles, Motorcycles, bicycles and accessories	Tüyap Diyarbakır Fuar ve Kongre Merkezi	Diyarbakır	Tüyap Tüm Fuarçılık Yapım A.Ş.
02.10.2018	08.10.2018	Boat Show Eurasia	Tekne ve Tekne Ekipmanları, Marin Aksesuarları	Viaport Marina Tuzla	İstanbul	Via Fuarçılık A.Ş.
03.10.2018	05.10.2018	3rd International Roads, Bridges and Tunnels Fair	Road construction technologies, infrastructure, machinery	İstanbul Kongre Merkezi	İstanbul	MCI Fuarçılık Dış Ticaret Ltd. Şti
04.10.2018	07.10.2018	Turkey Construction Technologies and Industrial Building Fair	Building Technologies, Construction materials	ATO Kongre ve Sergi Sarayı	Ankara	Artı 2 Fuarçılık Ltd. Şti
11.10.2018	14.10.2018	SHF Fire & Rescue Exhibition	Fire, emergency, rescue	İstanbul Fuar Merkezi Yeşilköy	İstanbul	Marmara Tanıtım Fuarçılık Org. Rek. ve Tic. A.Ş.
13.10.2018	21.10.2018	Autoshow 4th Automobile and side Industry Fair	Automobile, Commercial Vehicles, Accessories and Side Industry	ANFA Altnpark Fuar Merkezi	Ankara	İnfo Uluslararası Fuar Tan. Org. A.Ş.
16.10.2018	21.10.2018	Samsun 3rd Autoshow Fair	Automobile, Commercial Vehicles, Motorcycles, Bicycles and Accessories	Tüyap Samsun Fuar ve Kongre Merkezi	Samsun	Tüyap Tüm Fuarçılık Yapım A.Ş.
24.10.2018	27.10.2018	İstanbul Marble Fair 2018 15. International Marble, Natural Stone Products and Technologies Fair	Marble, Natural Stone and Technologies	İstanbul Fuar Merkezi Yeşilköy	İstanbul	Pozitif Fuarçılık A.Ş.
24.10.2018	27.10.2018	Bursa 4th International Marble Block Fair 2018	Block Marble, Plate Block, Travertine Block, Limestone, Onyx, Granite, Decorative Stones, Construction Mach.	Bursa Uluslararası Fuar ve Kongre Merkezi	Bursa	Tüyap Bursa Fuarçılık A.Ş.
25.10.2018	27.10.2018	Ankiros 2018 14. International Iron-Steel & Foundry Technology, Machinery And Products Trade Fair	Raw Material, Machinery, Equipment, Technology, Products And Services	Tüyap Fuar ve Kongre Merkezi	İstanbul	Hannover Messe Ankiros Fuarçılık A.Ş.
14.11.2018	16.11.2018	International Logitrans Transport Logistics Exhibition	Freight Transport and Logistic Services, Transport Vehicle and Systems, IT, Telematics, Telecommunications, Intralogistics, Materials Flow and Storage Systems	İstanbul Fuar Merkezi Yeşilköy	İstanbul	Eko MMI Fuarçılık Tic. Ltd. Şti.
23.11.2018	26.11.2018	Comvex İstanbul 2018	Commercial vehicles, buses, components, service equipments	Tüyap Fuar ve Kongre Merkezi	İstanbul	Tüyap Tüm Fuarçılık Yapım A.Ş.



Türkiye'nin Conecto'su yollarda.

Mercedes-Benz'in üstün teknolojisi ve yenilenen tasarımı sayesinde yüksek yakıt tasarrufu sağlayan Conecto, dizel ve doğalgazlı (CNG) motor seçenekleri ile her zaman hizmete hazır.

Mercedes-Benz
İletişim Hattı
4446244

www.mercedes-benz.com.tr
www.facebook.com/MercedesBenzOtobus
www.instagram.com/mercedesbenzotobus

Mercedes-Benz
The standard for buses.



Bankkart Combo

Seni düşünür o



Kredi kartı ve banka kartı tek kartta!

 Ziraat Bankası



Seni düşünür o
bankkart
Combo

 /bankkart

0850
258
00 00 Müşteri İletişim
Merkezi
www.bankkart.com.tr